



**John  
BOOS**  
Since 1887

ITEM #: \_\_\_\_\_ QTY: \_\_\_\_\_

MODEL #: \_\_\_\_\_

PROJECT NAME: \_\_\_\_\_

061318

3601 S. Banker St. Effingham, IL 62401 • P.O. BOX 609 • Ph: (888) 431-2667 • Fax: (800) 433-2667

## **"WAL-C" BLENDED WALNUT CLASSIC COUNTRY WORK TABLE**

**1-1/2" THICK**

### **FEATURES:**

- AMERICAN BLACK WALNUT
- FINGER JOINTED BLENDED TOP
- END GRAIN
- BOOS BLOCK CREAM WITH BEESWAX FINISH

### **SIZES:**

- THICKNESS: 1-1/2"
- SIZE: AVAILABLE IN VARIOUS SIZES
- WEIGHT: AVAILABLE IN VARIOUS WEIGHTS



### **"R-LZ" LAZY SUSAN - EDGE GRAIN W/ VARNIQUE FINISH**

MODEL #	QTY
WAL-C3625	
WAL-C4825	
WAL-C6025	
WAL-C4830	
WAL-C6030	
WAL-C4836	
WAL-C6036	

# DETAILED SPECIFICATIONS

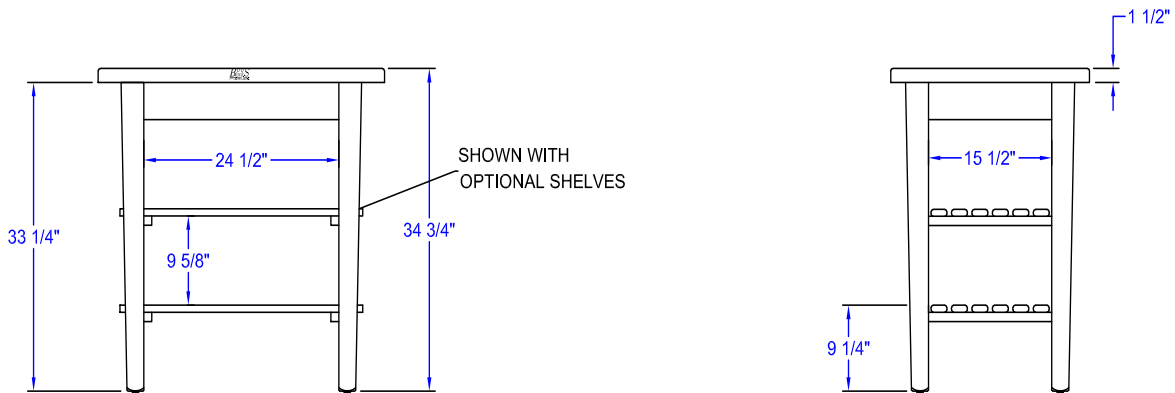
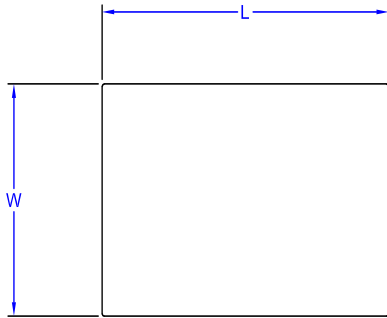

## "R-LZ" LAZY SUSAN - EDGE GRAIN W/ VARNIQUE FINISH

MODEL #	BOARD SIZE	NO SHELF WEIGHT	1 SHELF WEIGHT	2 SHELF WEIGHT
WAL-C3625	36" X 25" X 1-1/2"	58	78	100
WAL-C4825	48" X 25" X 1-1/2"	77	97	122
WAL-C6025	60" X 25" X 1-1/2"	86	114	140
WAL-C4830	48" X 30" X 1-1/2"	84	111	151
WAL-C6030	60" X 30" X 1-1/2"	101	133	160
WAL-C4836	48" X 36" X 1-1/2"	103	143	162
WAL-C6036	60" X 36" X 1-1/2"	121	153	195

SOME UNITS SHIP UNASSEMBLED FOR REDUCED SHIPPING COST. ALL DIMENSIONS ARE TYPICAL. TOLERANCE +/- .500"  
 John Boos & Co. is constantly engaged in a program of improving products and therefore reserves the right to change specifications without prior notice.



Boos  
lock

AQ AutoQuotes

3601 S. Banker St. • Effingham, IL 62401 • PO BOX 609 • quotes@johnboos.com

[www.johnboos.com](http://www.johnboos.com)

061318

117