

# DESIGNER LINE REFRIGERATOR

## Model: **D1RENPTHD**

Natural Refrigerant R-290 Model



### 1-Section Extra-Wide Pass-Thru Refrigerator with Half Doors

- D1RENPTHD** - Stainless steel front, aluminum end panels and interior
- D1RENSAPTHD** - Stainless steel exterior, aluminum interior
- D1RENSSPTHD** - Stainless steel exterior and interior



## Options and Accessories

(upcharge and lead times may apply)

Stainless steel case back	Casters
Additional epoxy coated steel shelves	Pan slide assemblies
Chrome or stainless steel shelves	Custom laminates
Pass-thru (consult factory)	Special electrical req. (consult factory)
Full door	<b>Correctional Facility Options</b>
Hinged glass door (consult factory)	• One way security screws
Rehinging of doors (consult factory)	• Locking hasp (lock not included)
Wine rack	• Stainless steel mesh cover
	• Coverless hinges

Consult factory for other model configurations, options and accessories.



Toll-Free: 800-523-7138  
Phone: 215-244-1400  
Fax: 215-244-9579

539 Dunksferry Road  
Bensalem, PA 19020  
[www.continentalrefrigerator.com](http://www.continentalrefrigerator.com)

Project Name:

Model Specified:

Location:

Item No:

Quantity:

AIA #:

SIS #:

## Standard Model Features

### REFRIGERATION SYSTEM

Self contained, performance rated "plug" refrigeration system

Natural, environmentally safe, high efficiency R-290 refrigerant<sup>1</sup>

Refrigeration system is readily accessible on top of cabinet, separate from the "food zone"

Automatic, hot gas condensate evaporator

Expansion valve system

### CABINET ARCHITECTURE

3" non-CFC polyurethane foam insulation

Smooth, polished chrome workflow door handles

Cam action, lift off hinges

Self-closing doors

Magnetic snap-in Santoprene™ door gaskets

Cylinder lock in each door

Heavy duty pilaster strips

Heavy duty, epoxy coated steel shelves

Adjustable 6" stainless steel legs

### MODEL FEATURES

LED interior lighting

Electronic controller with digital display & hi-low alarm

Off-cycle defrost

Top and side air distribution ducts

Cabinet upper side panels and refrigeration "plug" system can be removed and reinstalled at job site

<sup>1</sup> R-290 refrigerant meets all federal and state regulatory requirements.

APPROVAL:

# Model Specifications

## DIMENSIONAL DATA

Net Capacity (cubic feet)	22 (623 cu l)
Width, Overall (inches)	28 1/2 (724 mm)
Depth, Overall (inches) (including handles)	38 3/4 (984 mm)
Depth (inches) (less doors)	32 (813 mm)
Depth (inches) (doors open 90°)	79 (2007 mm)
Clear Door Width (inches)	21 7/8 (556 mm)
Clear Half Door Height (inches)	27 1/2 (699 mm)
Height, Overall (inches) (including 6" legs)	83 1/4 (2115 mm)
Number of Doors	4
Number of Shelves	3
Shelf Area (square feet)	20.4 (1.9 sq m)
Tray Slide Capacity (per half section)	11

## REFRIGERANT DATA

Condensing Unit Size (H.P.)	1/4
Capacity (BTU per hour)*	1940

## ELECTRICAL DATA

Voltage (International)	115/60/1 (220/50/1)
Feed Wires (including ground)	3
Total Amps (International)	5.5 (3.9)
10 ft. Cord/Plug [attached] (International)	Yes (No)

## SHIPPING DATA

Height - Crated (inches)	85 1/2 (2172 mm)
Width - Crated (inches)	31 5/8 (803 mm)
Depth - Crated (inches)	42 (1067 mm)
Volume - Crated (cubic feet)	65 (1841 cu l)
Weight Std - Crated (pounds)	370 (168 kg)
Weight SS - Crated (pounds)	390 (177 kg)

\* Rating @ +25°F evaporator, 90°F ambient  
Figures in parentheses reflect metric equivalents rounded to the nearest whole unit.



Equipped with one NEMA-5-15P Plug  
(varies by country)

# Model Plan Views

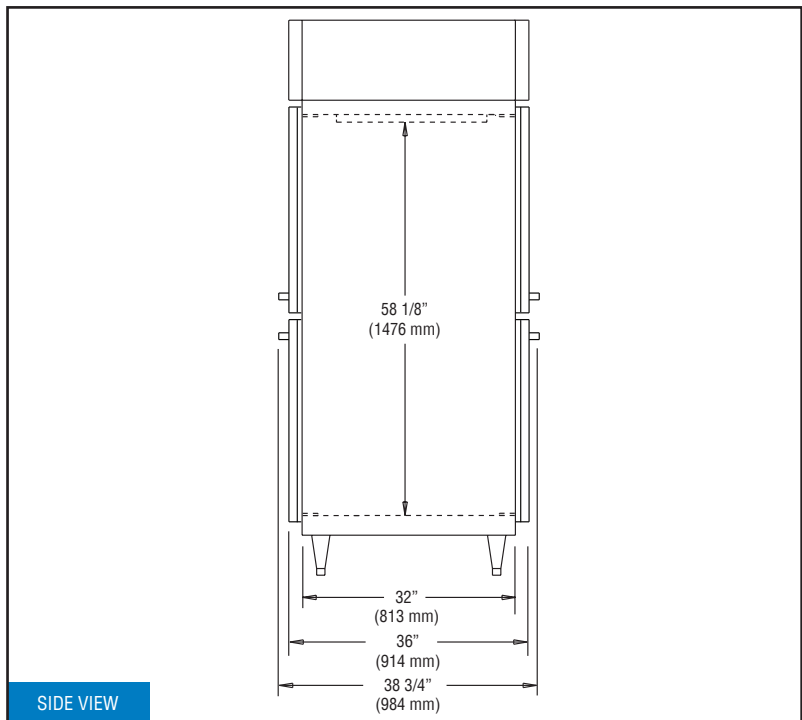
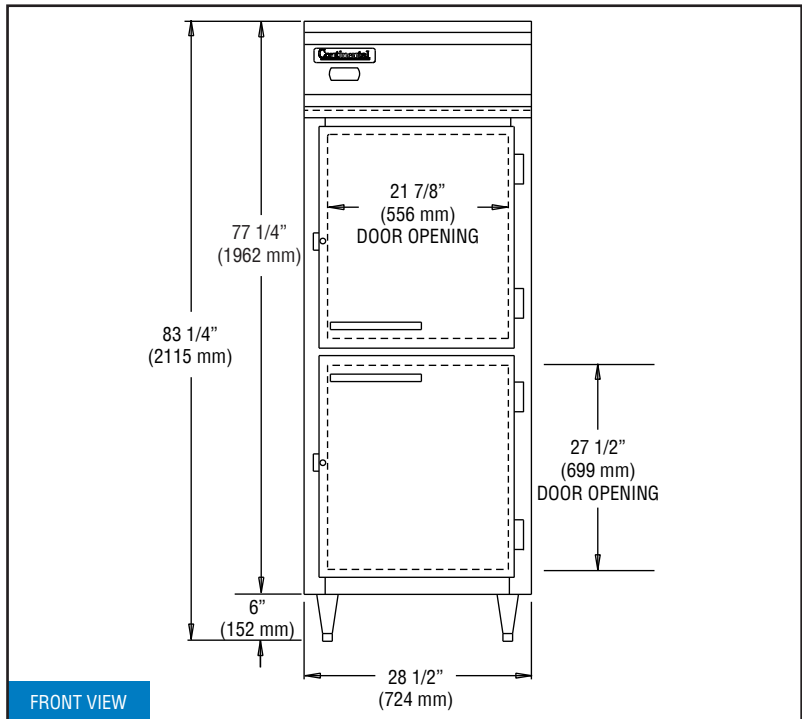

**IMPORTANT NOTE:** If the cabinet is located under a low ceiling, a minimum clearance of 12" is required on top and 3" on sides.



Toll-Free: 800-523-7138  
Phone: 215-244-1400  
Fax: 215-244-9579

539 Dunksferry Road  
Bensalem, PA 19020  
[www.continentalrefrigerator.com](http://www.continentalrefrigerator.com)

Due to our continued efforts in developing innovative products, specifications subject to change without notice.

