



Project:
Item:
Quantity:

POLAR 2-50 COMBIVAC
DOUBLE CHAMBER VACUUM SEALER



FEATURES

- Seal bar length: 2 x 24.4" (front-back)
- Standard double seal (seal bars with two wires, for double security)
- Available for free: Cut-off or Wide seal
- Seal bar system mounted in lid and easily removable for cleaning and maintenance purposes
- Pump capacity: 4,237 cf/h (120 m3/h) Busch vacuum pump
- Pump maintenance and cleaning program
- Machine cycle: 15-40 sec
- **Standard CombiVac control system** with 20 program memory and Sensor control: max. 99.8%, for an optimum end vacuum
- Soft Air to protect the product and vacuum bag
- Stainless steel lid
- Flat working plate
- Comes with insert plates for a faster cycle and product adjustment
- Stainless steel exterior
- 12ft cord with NEMA L15-30 plug

DESCRIPTION

The robust, stainless steel Polar 2-50 double chamber vacuum packaging machine is standard equipped with a Busch vacuum pump. This CombiVac industrial model is ETL listed and complies with UL, CSA and CE standards.



WARRANTY

Henkelman Inc offers a warranty of 1 year on labor and 3 years on parts. For full warranty details, please refer to www.henkelman.com.

OPTIONS

- 1-2 Cut-off seal/Bi-active seal
- Gas flush
- Liquid Control
- Digital control with 10 program panel (and Sensor control)
- Extra seal capacity
- Preparation for external pump
- Heavy duty seal bars

ACCESSORIES

- Inclined insert plate
- Label printer (only icw CombiVac control)
- Service kit for standard maintenance

DATE

APPROVAL



<https://www.henkelman.com/us>

HENKELMAN INC. Sales and technical support
493 W Fullerton Ave P +1 331 979 2013
Elmhurst IL, 60126 F +1 630 359 3875
E info@henkelmanusa.com

VACUUM SEALER POLAR 2-50 COMBIVAC – SPEC SHEET

DOUBLE CHAMBER VACUUM SEALER POLAR 2-50 COMBIVAC SPECS

VACUUM SEALER POLAR 2-50 COMBIVAC - SPEC SHEET

DIMENSIONS

In inches

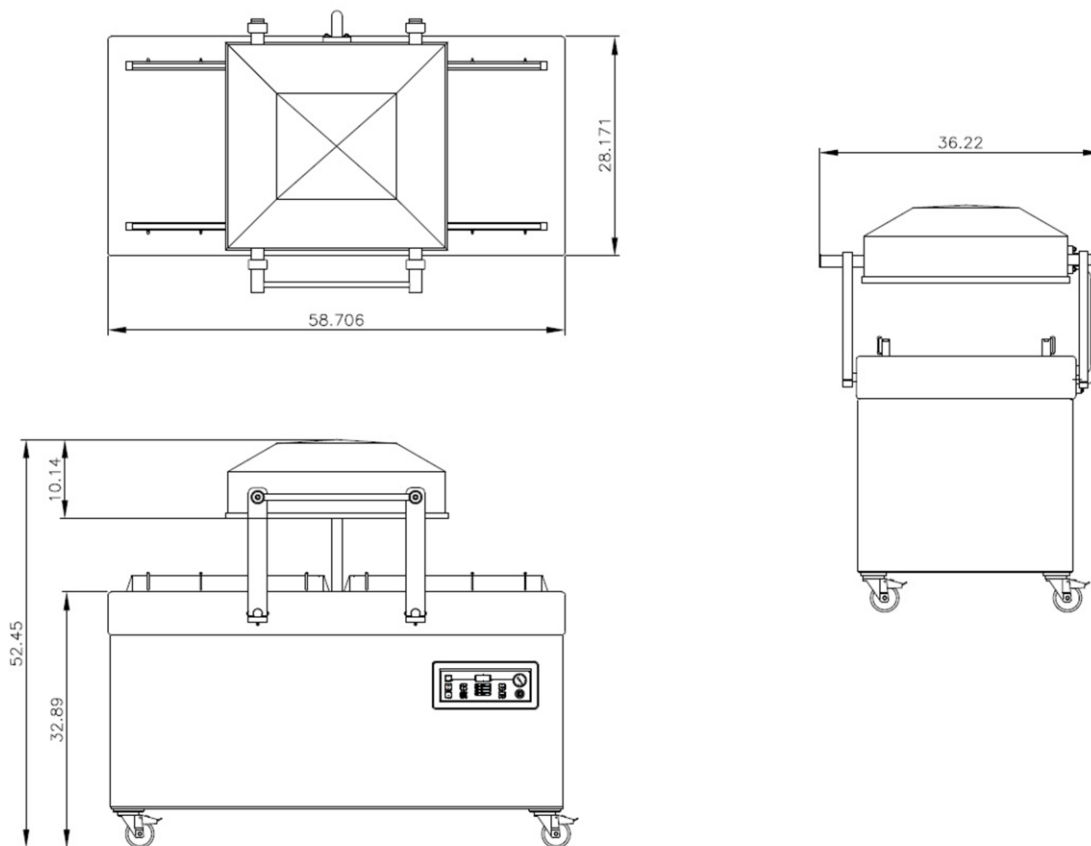

Model	Dimensions (inches)		Volts	Amps	Hz	Pump capacity	HP	Plug	Weight (lbs)
	Chamber L x W x H (usable space in inch)	Machine L x W x H (in inch)							
Polar 2-50 CombiVac	19.6" x 24.4" x 9.4"	36.2" x 58.7" x 43"	208	24/ 24 C*	60Hz	4,237 cf/h (120 m ³ /h)	4.6	NEMA L15-30P	761



L15-30P

3 pole, 4 wire grounding 3 x 208 Volt

*This is the minimum fuse value with the recommended characteristic



<https://www.henkelman.com/us>

HENKELMAN INC.
493 W Fullerton Ave
Elmhurst IL, 60126

Sales and technical support
P +1 331 979 2013
F +1 630 359 3875
E info@henkelmanusa.com