



Profit from the Eagle Advantage®

Specification Sheet

Short Form Specifications

Eagle 1800 Series Ice Chests with Sealed-In Cold Plate, model _____ . Top, front, backsplash and ice bin to be heavy gauge type 304 stainless steel. Fabricated ice bin is fully insulated with 1½" drain, and sealed-in 7-circuit cold plate. 1½" O.D. galvanized tubular legs with adjustable bullet feet.



#B30IC-16D-18-7 ice chest with 16" (406mm)-deep ice bin

Options / Accessories

- Stainless steel leg kits (see below)
- Speed rails

Item No.: _____
 Project No.: _____
 S.I.S. No.: _____

1800 Series Ice Chests with Sealed-In Cold Plate

MODELS:

- | | | |
|---|---|---|
| <input type="checkbox"/> B2IC-18-7 | <input type="checkbox"/> B30IC-16D-18-7 | <input type="checkbox"/> B42IC-12D-18-7 |
| <input type="checkbox"/> B2IC-12D-18-7 | <input type="checkbox"/> B36IC-18-7 | <input type="checkbox"/> B42IC-16D-18-7 |
| <input type="checkbox"/> B2IC-16D-18-7 | <input type="checkbox"/> B36IC-12D-18-7 | <input type="checkbox"/> B48IC-18-7 |
| <input type="checkbox"/> B30IC-18-7 | <input type="checkbox"/> B36IC-16D-18-7 | <input type="checkbox"/> B48IC-12D-18-7 |
| <input type="checkbox"/> B30IC-12D-18-7 | <input type="checkbox"/> B42IC-18-7 | <input type="checkbox"/> B48IC-16D-18-7 |

Design and Construction Features

- Bullnose front edge.
- Stainless steel type 304 ice bin, backsplash, front, and sliding ice cover.
- Galvanized ends and back panel.
- Models come with 8", 12" or 16" (203, 305 or 406mm)-deep ice bin.
- 1½" (38mm) drain centered.
- Ice bins are fabricated.
- High-impact, corrosion-resistant, fully-adjustable bullet feet.
- Post-mix cold plates: aluminum casting with seven stainless steel beverage grade tubing circuits. Cold plates are post-mix, mounted flush with interior bottom of ice bin for easy cleaning and maximum efficiency. Drain is ½" (13mm) NPT and centered in ice bin front and back. ¼" (6mm) tube connections provided.
- Packaging: Ice chests with cold plates shipped wood-crated.

Optional Stainless Steel Leg Kits for Ice Chests	
add suffix #	description
-SL	stainless steel leg assemblies
-SLF	stainless steel leg assemblies & stainless steel feet
-SLG	stainless steel leg assemblies & stainless steel gussets
-SLGF	stainless steel leg assemblies, stainless steel feet & gussets

EAGLE GROUP
 100 Industrial Boulevard, Clayton, DE 19938-8903 USA
 Phone: 302-653-3000 • Fax: 302-653-2065
 www.eaglegrp.com

Foodservice Division: Phone 800-441-8440
MHC/Retail Display Divisions: Phone 800-637-5100

For custom configuration or fabrication needs, contact our **SpecFAB® Division**.
 Phone: 302-653-3000 • Fax: 302-653-2065 • e-mail: quotes@eaglegrp.com



EG40.04B Rev. 07/18

Spec sheets available for viewing, printing or downloading from our online literature library at www.eaglegrp.com



Item No.: _____
 Project No.: _____
 S.I.S. No.: _____

1800 Series Ice Chests with Sealed-In Cold Plate

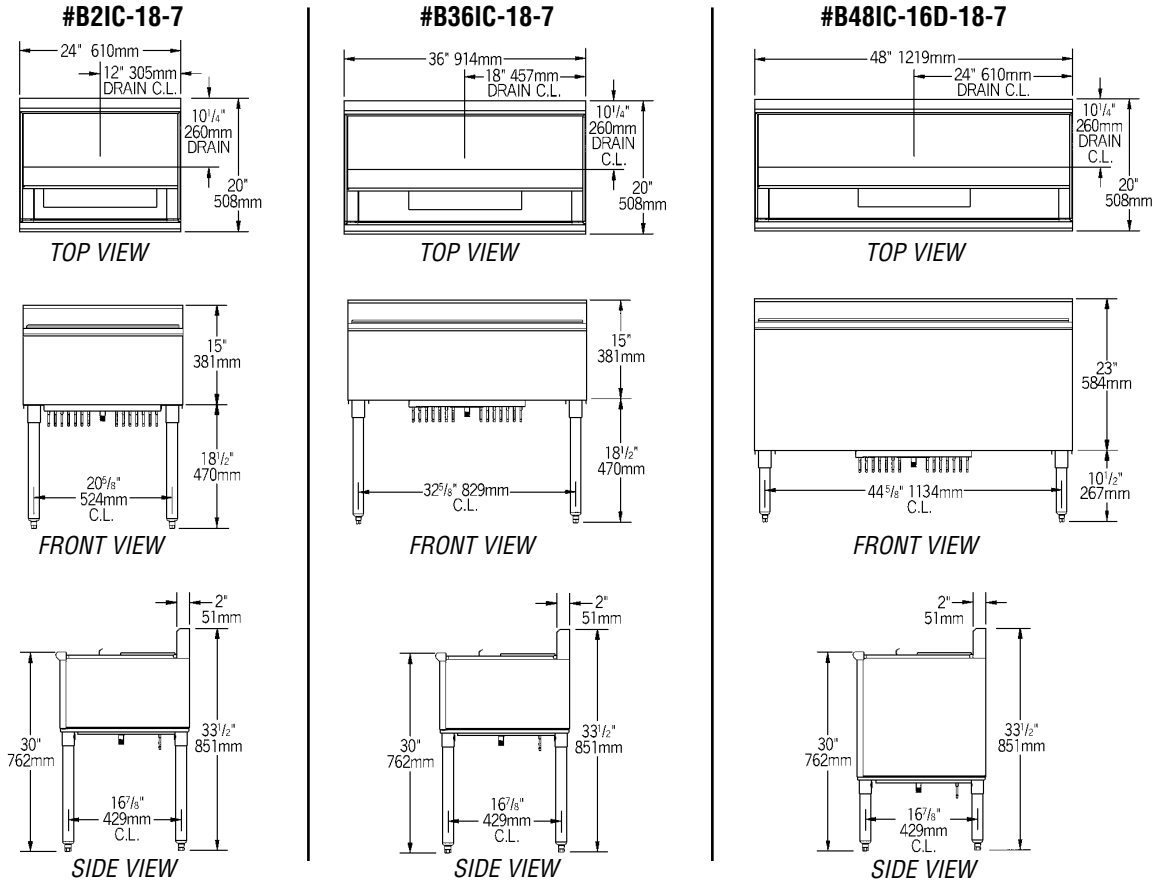

model #	width x length		weight		ice bin depth		ice capacity	
	in.	mm	lbs.	kg	in.	mm	lbs.	kg
B21C-18-7	20"	24"	132	59.9	8"	203	37	16.8
B21C-12D-18-7	20"	24"	167	75.8	12"	305	55	24.9
B21C-16D-18-7	20"	24"	175	79.4	16"	406	73	33.1
B30IC-18-7	20"	30"	136	61.7	8"	203	48	21.8
B30IC-12D-18-7	20"	30"	168	76.2	12"	305	71	32.2
B30IC-16D-18-7	20"	30"	193	87.5	16"	406	95	43.1
B36IC-18-7	20"	36"	152	68.9	8"	203	59	26.8
B36IC-12D-18-7	20"	36"	187	84.8	12"	305	88	39.9
B36IC-16D-18-7	20"	36"	198	89.8	16"	406	117	53.1
B42IC-18-7	20"	42"	169	76.7	8"	203	70	31.8
B42IC-12D-18-7	20"	42"	189	85.7	12"	305	105	47.6
B42IC-16D-18-7	20"	42"	228	103.4	16"	406	140	63.5
B48IC-18-7	20"	48"	211	95.7	8"	203	81	36.7
B48IC-12D-18-7	20"	48"	233	105.7	12"	305	121	54.9
B48IC-16D-18-7	20"	48"	245	111.1	16"	406	162	73.5

EAGLE GROUP
 100 Industrial Boulevard, Clayton, DE 19938-8903 USA
 Phone: 302-653-3000 • Fax: 302-653-2065
 www.eaglegrp.com

Foodservice Division: Phone 800-441-8440
 MHC/Retail Display Divisions: Phone 800-637-5100

Printed in U.S.A.
 ©2018 by Eagle Group
 Rev. 07/18

Spec sheets available for viewing, printing or downloading from our online literature library at www.eaglegrp.com

Although every attempt has been made to ensure the accuracy of the information provided, we cannot be held responsible for typographical or printing errors. Information and specifications are subject to change without notice. Please confirm at time of order.