

140 fire show series g



High-temperature pizza oven
 Cooking range is from 600f - 800f
 Rotating floor, Gas temperature control'

- Glass heat shield doors
- Granite ledge
- Steel night cover door
- Automatic ignition control
- Rotating floor
- Red metallic finish
- Electric floor heat
- Adjustable floor speed
- Facade and dome ready or standalone
- Installation through any 36" doorway.



Hearth size 55"	
12" Pizzas	14
16" Pizzas	6

MODEL	140 Fire Show series G	
ITEM #		
CONFORMS TO UL 737/ 2162, ANSISTDZ83.311 CONFORMS TO NSF /ANSI STD 4 CERTIFIDE TO CSA STD 1.8ULC/ORDSTDC2162 FOR FOOD SERVICE EQUIPMENT TESTED AND APPROVED FOR UL 737 DIRECT VENT.		

WEIGHT: 4000 lbs.
Width 71" Height 73.5" Depth 78"

All ovens are installed by a factory representative only on location

FOR DIRECT VENTING: It is never appropriate to use "B vent" in any part of an exhaust system connected to your oven. All duct material must be manufactured to the following specifications: UL1978 and/or UL 2221 - NFPA 96 and the International Mechanical Code.

The duct serving this oven should be inspected at least twice a month during the first two months of operation to establish rate of, or any buildup and necessary cleaning schedule. Venting should have clean-out doors according to code. Submit venting plans to your local authorities before proceeding with your installation, as there may be additional requirements in your area.

140 fire show series g



Manufacturer venting recommendations:

DIRECT VENT: Use an 8" interior grease duct connection pipe. Direct venting connection can be used with a power ventilator. Follow all manufacturers' instructions on venting pipe construction and installation.

Direct vent manufacturers: www.duravent.com

All fans on direct ventilation installations should be rooftop or exterior mounted at flue pipe termination. They should have a variable speed control switch to balance air flow. Preferably located near the front of the oven. The fan should be rated for 475F.

FAN RECCOMENDATIONS [visit www.energex.com](http://www.energex.com)

- Energex GVS012 -016: High-temperature pizza fans
- Dilution bolts for fan mounting
- Variable fan speed control.
(To balance air-flow and set for proper venting velocity)
- CFM: 450
- Call for free design consultation

140 fire show series g



**8" CIX1 (1" INSULATION)
304/304**

ITEM NO.	QTY	PART NUMBER	DESCRIPTION	MATERIAL
1	1	CIX1-8SWAC	8" Dia. Single Wall Adapter	304
2	1	CIX1-8DLCC	8" Dia. Drain Length	304/304
3	1	CIX1-8F30C	8" Dia. Adjustable Flashing	304
4	1	CIX1-8GDRT	8" Dia. Grease Duct Roof/Floor Trimble	Galvalume
5	1	CIX1-8CRCC	Enervex fan	304
6	1	CIX1-8AP	8" Dia. Anchor Plate	Galvanized
7	4	CIX1-8L36CC	8" Dia. 36" Length	304/304
8	2	CIX1-8L12CC	8" Dia. 12" Length	304/304
9	1	CIX1-8LACC	8" Dia. Adjustable Length	304/304
10	2	CIX1-8E30CC	8" Dia. 30° Elbow	304/304
11	1	CIX1-8FARP	8" Dia. Full Angle Ring	304
12	3	S-650	Sealant	-
13	1	S-375	Sealant	-

JOB NAME	PIZZA OVEN VENT	PROJECT#	-
COMPANY	NY BRICK OVENS	REVISION	-
	USE AN INCH TAPERED ANCHOR WITH A SLOTTED ANGLE 45°	DRAWN BY	-
		DATE	-
		SHEET#	Sheet 1 of 1
PROJECT FOLDER			

CLEARANCES

Install the oven with a minimum 2" clearance on all sides from any combustible material.

Noncombustible materials can only be used for façade at the front of the oven.

There must be 24" clearance from the top of the oven to combustible materials.

Follow all local codes for venting as well as venting manufacturers' installation specifications.

Submit all plans for approval before installation of any venting.

UTILITIES

½" NPT connection - use ½ Lb. PSI regulator and shut-off valve before oven connection.

116,000 BTU Natural Gas (max) 177,000 BTU Propane (max)

140 fire show series g



ELECTRICAL SUPPLY

- (1) 115v-15amp outlet with proper grounds and (1) 208-240V 20-amp single-phase line. Plug receptacle type: NEMA 6-20 Max Load 13.5-amp 230v 115v 1.5 amps. Recommendation: Install separate electrical lines to prevent any overload or surge. Surge protection outlets are recommended.
- (2) Electrical Code Limitations: This appliance must be electrically grounded in accordance with local codes, or in the absence of local codes, with the National Electrical Code, ANSI/NFPA 70. Follow all local codes and submit all plans for approval as required by your municipality.

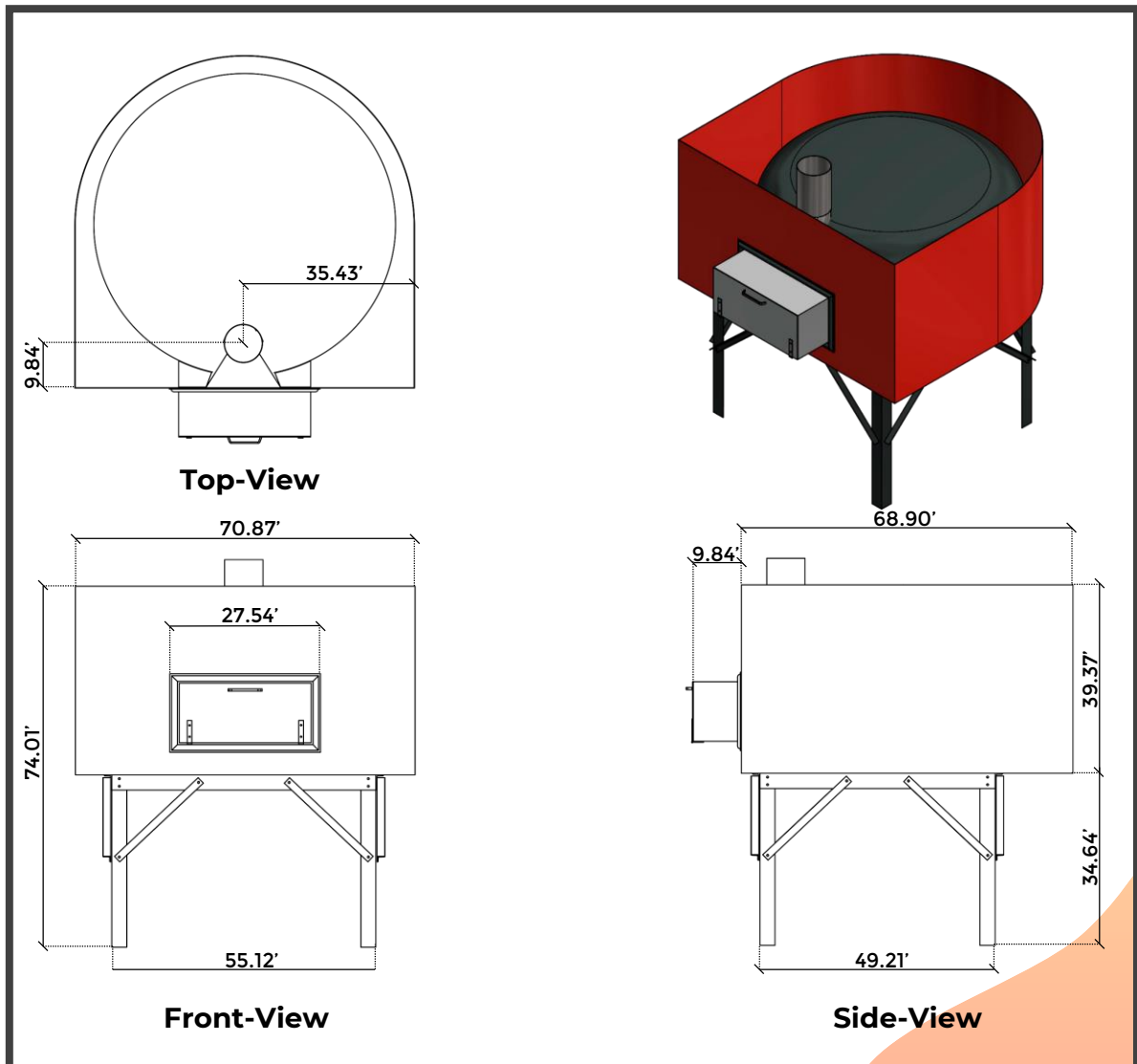

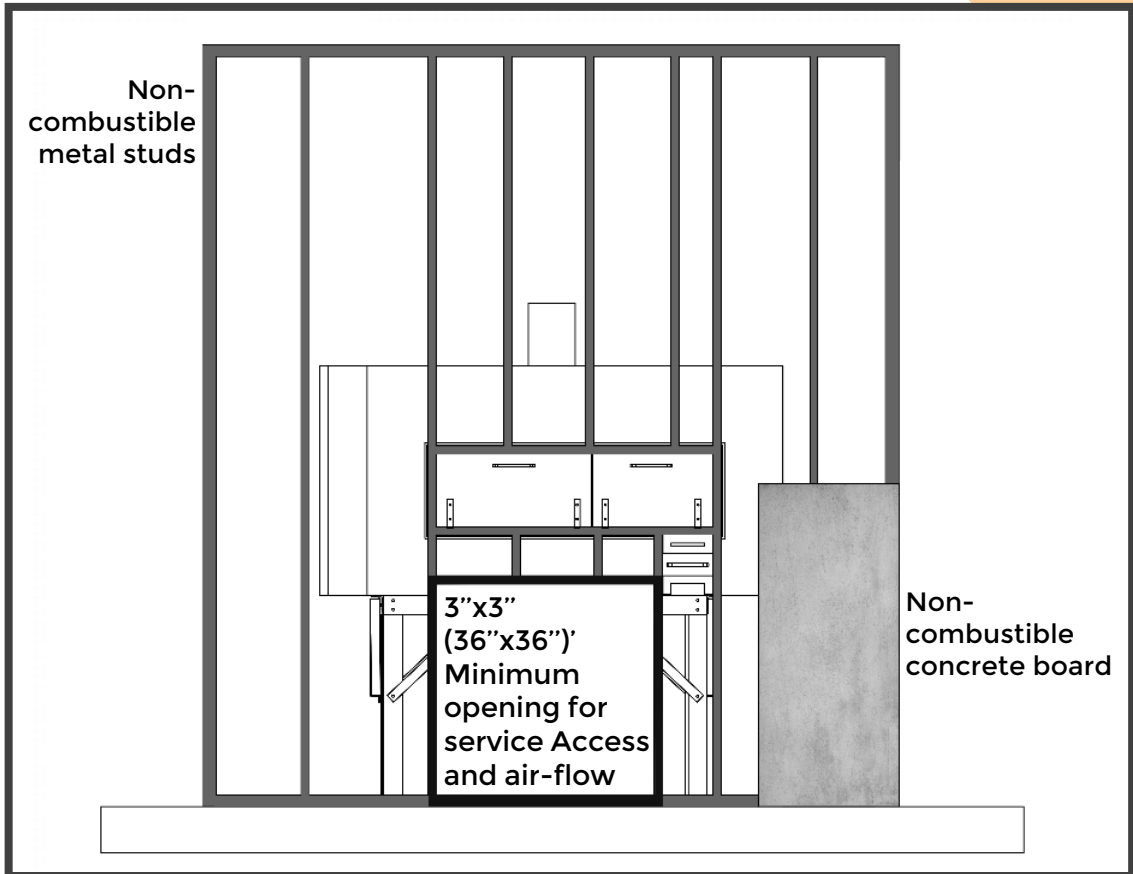

Oven Enclosure

Oven must be framed in with non-combustible materials *only*. Metal studs, backer board, tiles, or brick. See clearance data. Do not use sheetrock on oven façade.

Important

An accessible entrance must be installed at bottom of oven - approximately 36" x 36" for maintenance of oven and proper air-flow.

Warning

You Must Remove "Night Door" whenever igniting the oven or operating the oven. Do Not Operate or start oven with steel door closed ever. Only use the door at nights end to keep heat in. Read Operators Manual before using oven for first time. Following curing procedures. Follow all curing instructions prior to cooking in oven. Use Minimum flame setting for 2 days on low setting only 8 hours per day. Use dry seasoned hard wood only in wood chamber

