

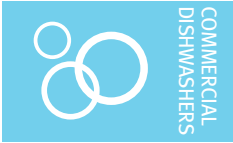

Project _____
 AIA # _____ SIS # _____
 Item # _____ Quantity _____ C.S.I. Section 114000



CL66-VL VENTLESS ELECTRIC

High Temperature Rack Conveyor Dishwashing Machine



STANDARD FEATURES

- + Ventless Energy Recovery technology
- + No exhaust cowls or exhaust hood required
- + 90 gallons per hour pumped final rinse
- + 202 racks per hour
- + 22" power scrapper
- + ENERGY STAR® Certified
- + Complete Delime™ with Delime Notification, Auto Dispensing and Booster Guard™
- + Internal stainless steel pressure-less 18 kW booster heater (70°F rise)
- + Single point electrical connection standard
- + Capless, anti-clogging wash arms
- + Self-aligning wash manifolds
- + Large double door opening for ease of cleaning
- + 19.5" chamber height opening (accepts sheet pans)
- + Doors are insulated & hinged with door interlock switches
- + User-friendly smart touchscreen controls with diagnostics & troubleshooting
- + WiFi connectivity
- + SmartConnect app and cloud with machine status, temperature logs, error code reporting, and cost, consumption and usage analysis
- + Energy saver mode (programmable auto-shut down)
- + NSF rated configurable pot and pan cycle
- + Stainless steel self-draining pump and impeller
- + Sloping scrap screens and deep scrap baskets
- + Rapid return conveyor drive mechanism
- + Service diagnostics
- + Door actuated drain closure
- + Integrated booster heater operation

SPECIFIER STATEMENT

Specified dishwasher will be Hobart CL66 Ventless electric tank heat model. Features include Ventless Energy Recovery, 22" power scrapper, Complete Delime™ with Delime Notification, Auto Dispensing and Booster Guard™, capless anti-clogging wash arms, 202 racks per hour, 90 gallons per hour pumped final rinse, ENERGY STAR®, insulated ergonomic cabinet style doors, touchscreen controls with WiFi connectivity, and NSF approved pot and pan cycle mode. The dishmachine uses energy efficient heat-pump ventless technology, combined with energy recovery, removes the need for direct venting while providing auxiliary heat to the wash tank. The 19.5" standard chamber height will accommodate up to (6) standard sheet pans at a time on an open-end sheet pan rack.

OPTIONS & ACCESSORIES (Available at extra cost)

- Drain water tempering kit
- Flanged feet kit (requires three kits)
- Table limit switch with 20' cable
- Correctional package (factory installed, contact Hobart for details)
- Water hammer arrester
- Factory-mounted circuit breakers (contact Hobart for details)

CL SERIES – CL66-VL VENTLESS ELECTRIC

Approved by _____ Date _____ Approved by _____ Date _____



CL66-VL VENTLESS ELECTRIC

High Temperature Rack Conveyor Dishwashing Machine

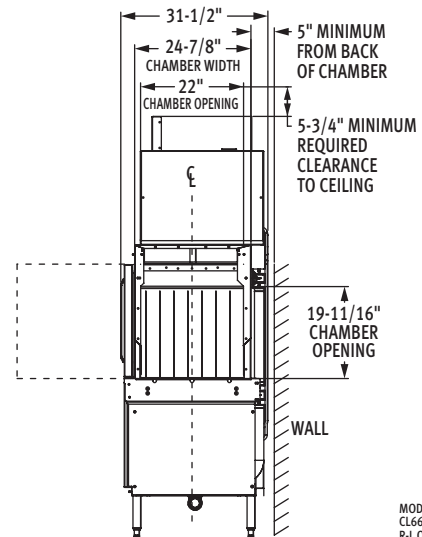
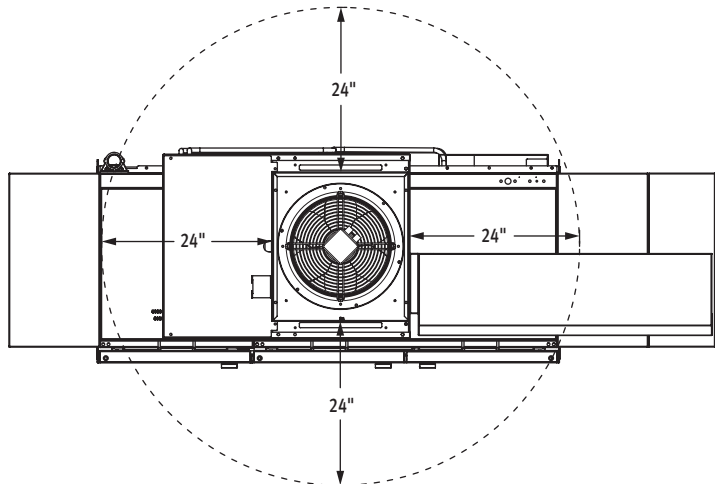
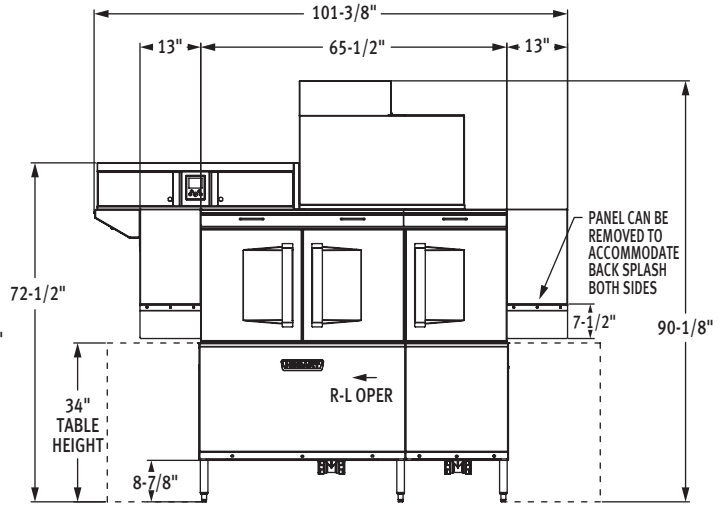
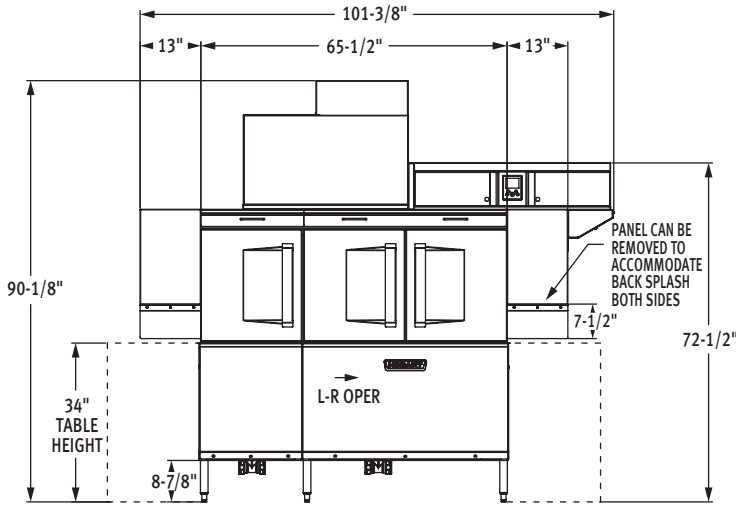
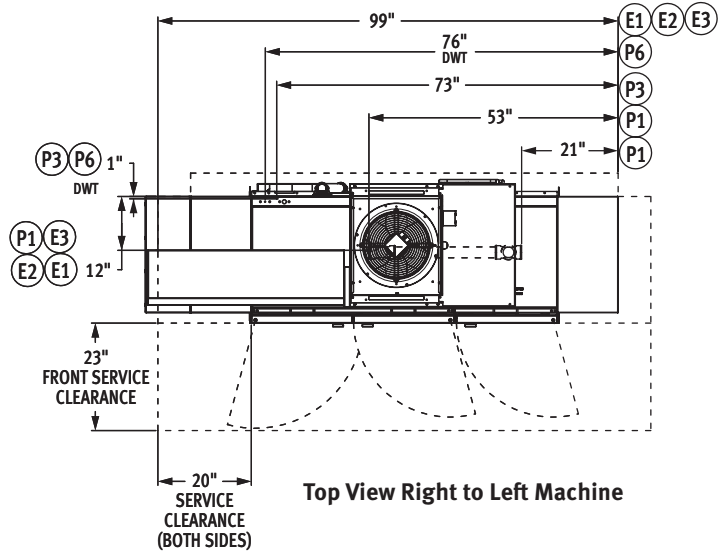
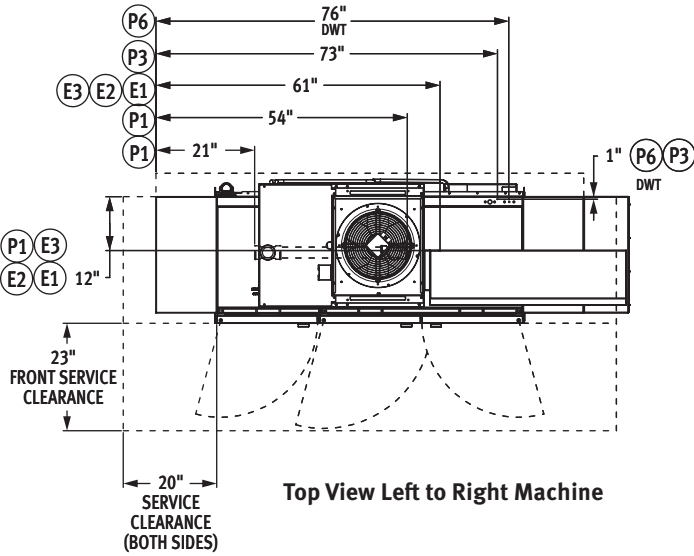

MODEL: CL66VL ELECTRIC
L-R OPERATION
00-563923
REV B

MODEL: CL66VL ELECTRIC
R-L OPERATION
00-563923
REV B



CL66-VL VENTLESS ELECTRIC

High Temperature Rack Conveyor Dishwashing Machine

LEGEND

Electrical Connections	
SINGLE POINT CONNECTION	
E1	Electric connection, single point: motors, controls, tank heat, 18 kW electric booster heater, compressor, 65" AFF.
DUAL POINT CONNECTION WITH BOOSTER	
E2	Electric connection: motors, tank heat, compressor, 62" AFF.
E3	Electric connection: controls, 18kW booster heater, 65" AFF.
Plumbing Connections	
P1	Drain: 2" FPT, 7-3/8" AFF, two possible connections; may be drained to either side of drain housing, plug opposite side.
P3	Cold water connection: 1/2" FPT, 12" AFF, 55°F minimum.
P6	Optional drain water tempering. Cold water connection: 1/2" FPT, 12" AFF, cold temperature 80°F maximum.

E1	Single Point Electrical Connection with Internal Booster	
Voltage	(E1) Motors, Controls, Tank Heat, 18 kW Booster Heater, Compressor	
	Rated Amps	Minimum Supply Circuit Ampacity/ Maximum Protective Device
208/60/3	115.0	150
240/60/3	103.3	125
480/60/3	52.1	70

Plumbing Notes: Water hammer arrestor (meeting ASSE-1010 standard or equivalent) to be supplied (by others) in common water supply line at service connection.

Recommended water hardness to be 3 grains or less for best results.

Building flowing water pressure to dish machine is 20 to 65 PSI at the machine.

For convenience when cleaning, water tap should be installed near machine with heavy duty hose and squeeze valve.

Miscellaneous Notes: All dimensions taken from floor line may be increased approximately 3/4" or decreased 1/2".

Electrical Note: Dishmachine not provided with internal GFCI protection.

SPECIFICATIONS

Capacities

Racks Per Hour (NSF rated)	202
Wash Tank (U.S. gallons)	21.5
Power Scrapper (U.S. gallons)	23
Conveyor Speed (feet per minute)	5.6
Refrigerant (R450A)	6.4 lbs.

Motor Horsepower

Compressor	4
Power Scrapper	2
Drive	1/6
Wash	2
Heat Pump Fan	1/6

Water Consumption

U.S. Gallons per Hour	90
U.S. Gallons per Rack	0.45
Peak Drain Flow (U.S. gallons per minute)	38

Heating

Tank Heat, Electric (kW)	9
Standard Electric Booster (kW)	18

Shipping Weight (approximate)

Dish Machine	1,345 lbs.
Heat Pump (ships separately)	275 lbs.

Crated Dimensions

Dish Machine	112"L x 38"W x 84"H
Heat Pump Assembly (ships separately)	52"L x 34"W x 36"H

E2 E3	Dual Point Electrical Connection with Internal Booster (Field Conversion Only)				
	Voltage	(E2) Motors, Tank Heat, Compressor		(E3) Controls, 18 kW Booster Heater	
Rated Amps		Minimum Supply Circuit Ampacity/ Maximum Protective Device	Rated Amps	Minimum Supply Circuit Ampacity/ Maximum Protective Device	
	208/60/3	56.5	70	58.5	70
	240/60/3	51.5	70	51.8	70
	480/60/3	24.9	35	27.2	35

CL66-VL Electric Heat Dissipation	
BTU/HR.	
Latent	Sensible
6,100	3,100

WARNING: Electrical and grounding connections must comply with the applicable portions of the National Electrical Code and/or other local electrical codes.

CAUTION: Certain materials including silver, aluminum, and pewter are attacked by sodium hypochlorite (liquid bleach).

ATTN: Plumbing connections must comply with applicable sanitary, safety and plumbing codes.



CL66-VL VENTLESS ELECTRIC High Temperature Rack Conveyor Dishwashing Machine

TABLE CONNECTION DETAILS

Tabling Connection: 44" inside tank
(at table connection)

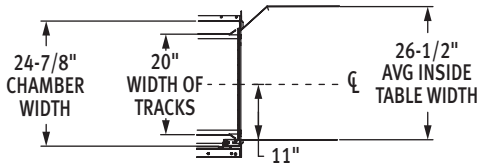

Suggested Track and Table Layout

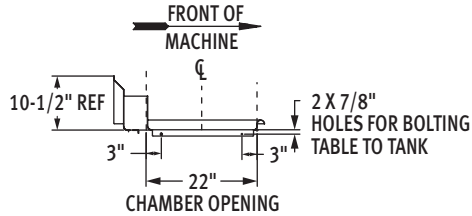

View Showing Hole Locations in
Turned Down Portion of Table



Sectional View Showing
Table Connections

As continued product improvement is a policy of Hobart, specifications are subject to change without notice.