

FlamBoyant™ FB1160-4E

DESIGN

The FlamBoyant range of rotisseries has been especially designed for high-volume cooking with high output and speed, while retaining excellent cooking quality. In addition, a wide array of accessories enable the rapid roasting of a variety of products.

Well designed, user friendly and reliable, the FlamBoyant is used by leading supermarkets and chain restaurants throughout the world.

FEATURES





- Energy efficient
- Tempered K-glass doors
- Independent motor for each spit
- Equipped with bottom drip tray with built-in drainage
- Reinforced and anti-warping heating element
- Powerful halogen lamp
- Delivered with 4 prongless chicken spits (CUI1160)
- Illuminated "Rotisserie" sign for enamel model only (optional)
- Base or stand on casters with brakes (optional)



FB1160-4E-SSP
Black porcelain enamel & chrome
shown with optional lighted roof & stand

TECHNICAL DETAILS

Overview of some of the standard features.

	Independent motors adjustable in depth for each spit		Robust hinges designed for heavy use, with integrated locking in open and closed positions		Easy and protected access to the compartment of connections and electrical components
	Reinforced heating elements with stainless steel holders to keep them in place and removable stainless steel panels for easy cleaning		Anti-scald K-glass reduces external thermal radiation (energy saving). Glass overlaps drip pan to keep splatters inside (anti-slip protection).		Removable inside side-panels doubles protection from grease seeping into motors and other sensitive parts.

ACCESSORIES

A variety of accessories are available. See video of available accessories and of vertical spit system online.

CUI1160 Anti-cutting prongless V-spit		BPOR1160 Porchetta spit		BRC1160 Rectangular basket spit	
BS1160 Spit for ham / turkey		BRRO1160 Roast-clamp spit		BA1160 Lamb/suckling-pig spit	
BCR1160 Spatchcock chicken basket		DEC Spit mover		PID1160 Tray for unspitting	

Front view
Rotisserie with roof

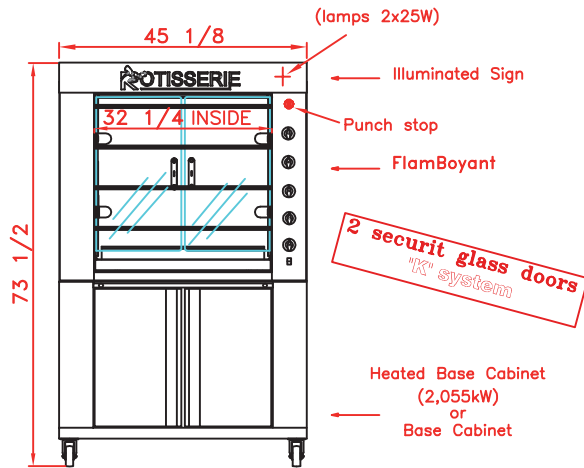

Top view
Rotisserie with roof

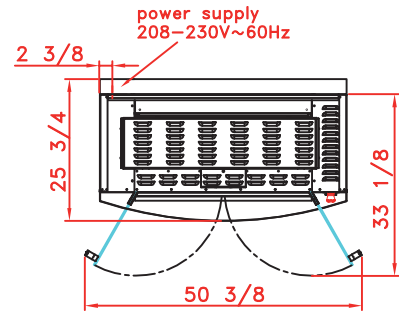

Side view
Rotisserie with roof

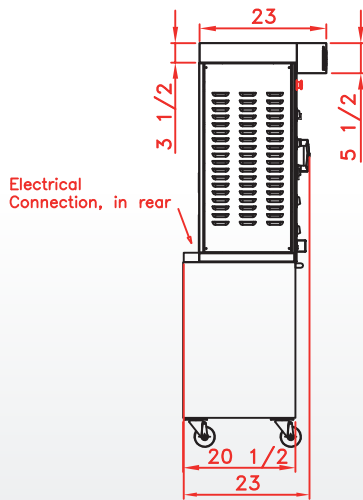

Revised
June 2021
April 2022 US

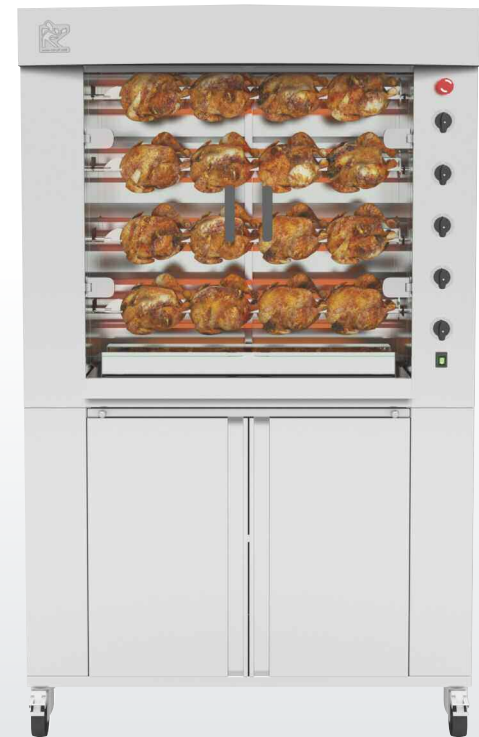

FB1160-4E-SS
Stainless steel & chrome
shown with optional roof & base

SPECIFICATIONS

Capacity	16-20 chickens
Power supply	208-230V/60Hz/3ph, 48.83 amps
Electrical power	13.36 kW
Weight and size (HxDxW)	375 lbs.; 73 1/2 x 25 3/4 x 45 1/8
Shipping weight and size	500 lbs.; 78 3/4 x 29 1/2 x 47 5/8
Warranty	1 year parts and labor

DISTRIBUTOR / AGENT

Rotisol France, Inc.
1450 W. 228th St. Unit 10, Torrance, CA 90501
info@rotisolusa.com
Ph: 310 671 7254
800 651 5969

