

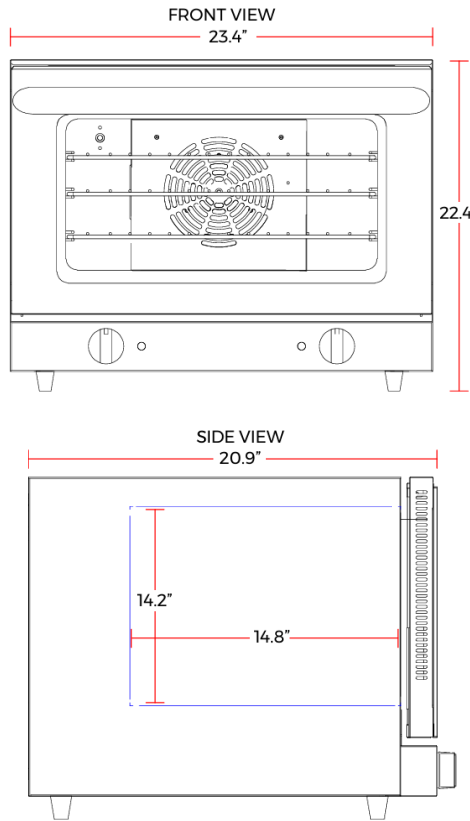

Tabletop Convection Oven

1/2 Size Model CCETTCOHS-120



Standard Features & Benefits

CONSTRUCTION: Insulated for efficiency. Easy cleaning stainless steel side housing with black satin door finish. Tempered glass door for easy viewing. Cool to the touch door handle. Rubber footers for cooler operation.

OVEN: Porcelain interior for easy cleaning and measures 18.5" w. x 14.5" d. x 9.75" h. Interior light for easier viewing. Chrome pan/rack rails with 4 bakery trays included. Dual round heaters with hi-speed fans for even heat distribution. Stainless steel baffle further assists even air flow.

CONTROLS: 120°F - 570°F thermostat control combined with high limit control for double safety. 120 minute timer bell.

POWER & TESTING: 120 Volts, 60 Hertz, Single Phase, 1.65 Kilowatt. NEMA 5-15P Plug Type. CSA design certified. Sanitation complies to NSF / ANSI standards.

All controls are tested and confirmed in good working order. Calibration and adjustments are the responsibility of the installer.

SPECS				
Model #	Width	Depth	Hgt.	Ship Wgt.
CCETTCOHS-120	23.5"	21"	22.5"	90 lbs.

 **WARNING:** This product can expose you to certain chemicals, which are known to the State of California to cause cancer or birth defects or other reproductive harm. For more information go to: www.P65Warnings.com

NOTICE: In an ongoing effort of product development & improvement, Comstock-Castle reserves the right to change specifications and product design without notice. Such modifications do not entitle the buyer to corresponding changes or replacements for previously purchased equipment.



Comstock-Castle Stove Co. • 119 W. Washington St. • Quincy, IL. 62301
Tel.: 217-223-5070 • Fax.: 217-223-0007 • Web: www.castlestove.com

