

SLIMLINE DROP-IN REFRIGERATED COLD PAN UNITS

Drop-in Cold pan units can be placed in existing countertops and other work areas to house items that need to be kept chilled. Perfect for cold bar items such as bottle drinks or salad bar items.

DISLRCP-4 Shown

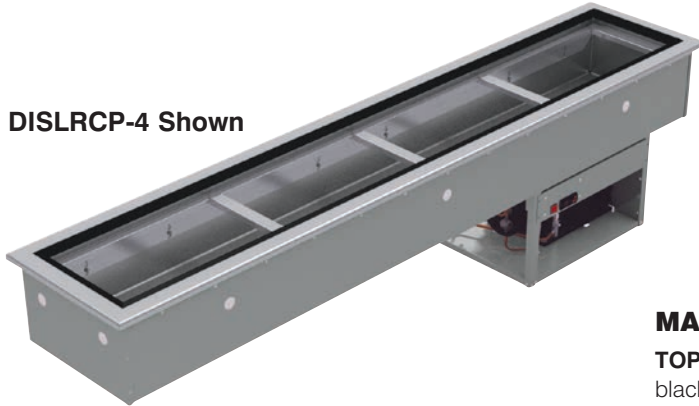

Item #:	_____	Qty #:	_____
Model #:	_____		
Project #:	_____		

FEATURES:

- High nominal cooling capacity for consistent product temperature control
- Aluminum encased copper tube evaporator panels improve heat transfer by increasing contact area
- This increases operating efficiency and reduces power consumption
- Expansion valve for efficient operation at various temperature conditions
- Refrigerant filter drier to insure cleanliness of sealed refrigeration circuit
- Sight glass to insure a properly charged refrigeration system
- Liquid receiver for improved refrigerant charge control
- Low running current suitable for any 115 volt circuit
- Precision electronic thermostat for exact temperature control
- Includes adapter bars for use with standard 12" x 20" pans

IMPORTANT NOTE:

The refrigeration compressor requires a free flowing supply of air for proper operation. For units installed in closed cabinets a minimum unobstructed air intake of 200 sq in and a separate exhaust of 200 sq in must be supplied by the installer or cabinet maker. Failure to provide adequate air intake and exhaust will void any warranty coverage on the unit.

MATERIAL:

- TOP:** 18 gauge, #304 stainless steel, with extruded black polyethylene thermal breaker marine edge
- INSULATION:** The pan is fully insulated and foamed in place with a 1-1/4" thickness on all sides and 2" thick on the bottom and enclosed with a 22 gauge galvanized steel outer jacket. This offers a lower heat gain into product
- LINER:** Constructed of 18 gauge, #304 stainless steel, with 3" recessed top, one piece construction, all welded, ground and polished to a uniform finish. All corners are covered with a 1/4" radius. Liner is pitched towards a 1" I.P.S. drain
- REFRIGERATION SYSTEM:** The compressor is housed in a 16 gauge galvanized under structure, fabricated from formed angles and bolted to the galvanized jacket. The fully self contained condensing unit is provided with a hermetically sealed compressor with a digital, programmable thermostat. The system is fully charged with environmentally friendly R404-A refrigerant
- ELECTRICAL:** Unit will be wired for 15 amps, 120V, single phase operation with an on/off thermostat switch. 6 ft. cord with NEMA 5-15P.
2-3 Well Units: 115v, 8 Amps, 60 Hz, 1/5 HP
4 Well Unit: 115v, 8 Amps, 60 Hz, 1/3 HP

Model #	Length (L)	Inside Length (B)	Cut-Out Size (Unit)	# of Wells	Refrigerant	Weight (lbs)	Cubic Feet
DISLRCP-2	49-5/8"	48"	17-3/8" x 48-3/8"	2	R404-A	205 lbs.	25
DISLRCP-3	71-1/4"	69-5/8"	17-3/8" x 70"	3	R404-A	257 lbs.	31
DISLRCP-4	92-7/8"	91-1/4"	17-3/8" x 91-5/8"	4	R404-A	325 lbs.	46

NOTE: Units are not designed to cool foods originally warm. Food should already be chilled to maintain the proper temperatures

SU-P-234 - 6' with NEMA 5-15P plug Included



WARNING: Refrigerated Equipment on this page may expose you to chemicals, including Ethanes, that are known to the State of California to cause cancer or birth defects or other reproductive harm. For more Info., visit www.p65warnings.ca.gov.

	Customer Service Available To Assist You 1-800-645-3166 8:30 am - 7:00 pm E.S.T.	
	For Orders: Email: customer@advancetabco.com or Fax To: 631-242-6900	For Smart Fabrication™ Quotes: Email: smartfab@advancetabco.com or Fax To: 631-586-2933
	www.advancetabco.com	

DIMENSIONS and SPECIFICATIONS

TOL \pm .125"

ALL DIMENSIONS ARE TYPICAL

