

Fusion

Product Specifications

ITEM NO: _____
 PROJECT: _____
 DATE: _____

Refrigerated Service Case - Meat/Seafood w/ Gravity & Platter Coil - Vertical

Lengths include 1-1/8" end panels
 51"L x 43"D x 51-5/8"H
 62-7/8"L x 43"D x 51-5/8"H
 75-3/8"L x 43"D x 51-5/8"H

- GMGV4
- GMGV5
- GMGV6



MODEL SHOWN: GMGV4

NOTE: SHOWN W/ OPTIONAL STAINLESS STEEL EXTERIOR

STANDARD FEATURES

- Breeze™ w/EnergyWise s/c refrigeration
- Compressor air intake from rear and out front panel at toe kick. Front panel cannot be blocked.
- Integrated average product temperature of 38°F or less
- LED 4000K top light(s)
- One year parts & labor; 5 year compressor warranty
- Stainless steel interior
- Stainless steel rear exterior
- Vertical, UV bonded lift-up front glass w/o lock

Features	Standard	Options
EXTERIOR COLOR	<input type="checkbox"/> Laminated (non-premium) Confirm pattern/grain direction	<input type="checkbox"/> Laminated (premium) Confirm pattern/grain direction <input type="checkbox"/> Painted (stock colors, specify RAL#) <input type="checkbox"/> Stainless steel
LOWER FRONT PANEL COLOR	<input type="checkbox"/> Painted - Black	<input type="checkbox"/> Stainless steel
TRIM COLOR	<input type="checkbox"/> Black	<input type="checkbox"/> Silver
BASE	<input type="checkbox"/> Casters w/ levelers (n/a w/ remote ref.)	<input type="checkbox"/> 6"H legs (n/a w/ remote ref.) <input type="checkbox"/> Rail system for shims (n/a w/ s/c ref.)
END PANEL LEFT	<input type="checkbox"/> Full end panel w/mirror interior	<input type="checkbox"/> Cutaway w/ glass
END PANEL RIGHT	<input type="checkbox"/> Full end panel w/mirror interior	<input type="checkbox"/> Cutaway w/ glass
UPPER REAR	<input type="checkbox"/> Clear glass rear sliding doors w/o lock	<input type="checkbox"/> Reflective glass rear sliding doors w/o lock
ELECTRICAL CONNECT	<input type="checkbox"/> 6' straight blade power cord (self-cont.)	<input type="checkbox"/> 6' locking power cord (self-cont.) <input type="checkbox"/> Electrical leads (remote)
REFRIGERATION	<input type="checkbox"/> Breeze™ w/EnergyWise s/c refrigeration	<input type="checkbox"/> NOTE: Remote only available w/rail base w/shims. N/A w/ levelers, casters or legs. <input type="checkbox"/> Note: Remote doesn't incl Conds unit. Floor drain reqd. <input type="checkbox"/> Remote w/thermostat, solenoid & TXV
MISCELLANEOUS		<input type="checkbox"/> Front glass lock <input type="checkbox"/> Ice pans for seafood application, requires floor drain <input type="checkbox"/> Rear door lock <input type="checkbox"/> Scale stand w/receptacle (requires separate circuit) <input type="checkbox"/> Second year parts & labor warranty (excludes compressor)
ACCESSORIES		<input type="checkbox"/> Clean Sweep® coil cleaner (n/a w/remote) <input type="checkbox"/> Rear wrapping board

Fusion

Product Specifications

Intended Environment: Type I - Designed to operate in ambient conditions of 75°F with 55% relative humidity unless noted otherwise in system information below.	
Zone	Intended Product To Be Displayed
1	Unpackaged refrigerated products
Warmest Avg Prod Temp ° F	
38	

PLAN VIEW

SIDE VIEW

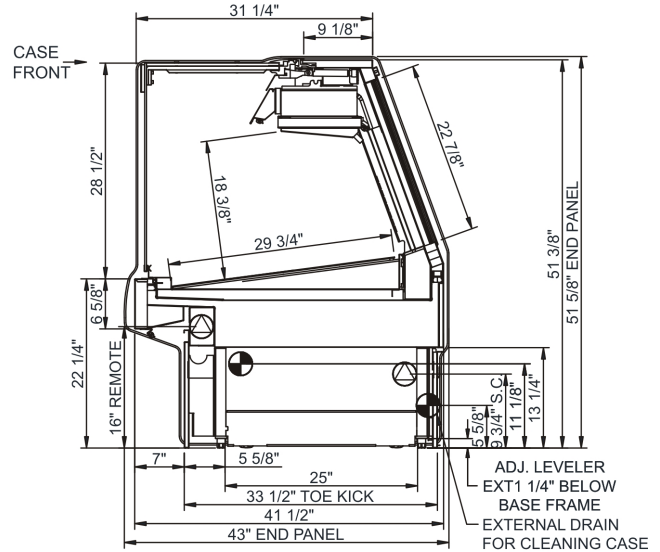
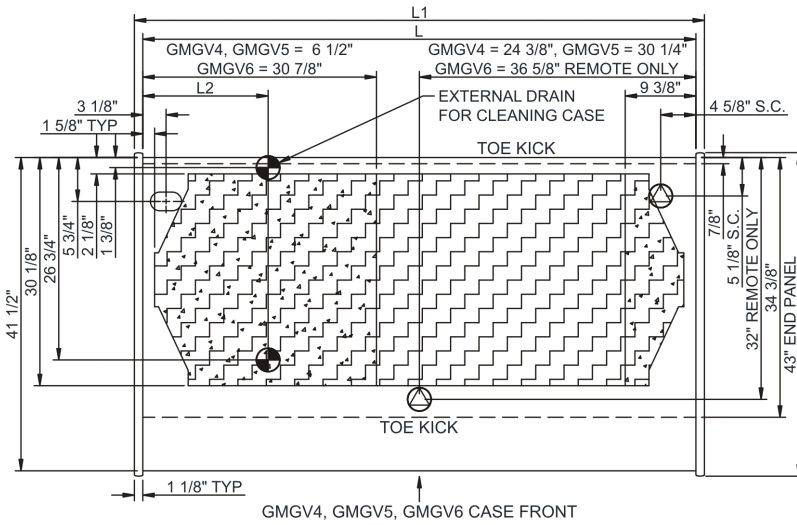

NOTE: ALL DIMENSIONS APPROXIMATE

- ELECTRICAL JUNCTION BOX (SUPPLIED WITH 6" LEADS OR POWER CORD).
- LOCATION OF DRAIN TUBE FOR REMOTE REF. ONLY (SUPPLIED WITH 3/4" OR 1 1/2" PVC TUBE).

- REFRIGERATION LINE CONNECTION.
- REMOTE FLOOR SINK & UTILITIES ACCESS AREA.

- SELF-CONTAINED CASE SERVICE ACCESS AREA.
- DRY CASE SERVICE ACCESS AREA.

Model Technical Specifications

Model	L"	L1"	L2"	System Circuit Volts		Phs	Freq	Amps ***	Watts	Wires	NEMA Plug	SST	Conv. Rack BTUH	Para. Rack BTUH	Est Wt	
GMGV4	48.75	51.00	13.38	Remote(Type I)	Circuit #1	110-120	1	60	1.79	63	2+G	Leads Multiple	20.00	1274	1180	1,200
				Self-Contained	Circuit #1	110-120	1	60	10.23	787	2+G	5-20P or L5-20P	N/A	N/A	N/A	
GMGV5	60.63	62.88	13.38	Remote(Type I)	Circuit #1	110-120	1	60	1.79	68	2+G	Leads Multiple	20.00	1521	1408	1,300
				Self-Contained	Circuit #1	110-120	1	60	10.23	792	2+G	5-20P or L5-20P	N/A	N/A	N/A	
GMGV6	73.13	75.38	16.63	Self-Contained	Circuit #1	110-120	1	60	10.54	832	2+G	5-20P or L5-20P	N/A	N/A	N/A	1,400

*** Does not include electric defrost on freezer models.

Regulatory Approvals:

All Models
 Accordance with AHRI Std 1200
 ETL Listed to UL 471
 ETL Listed to CAN/CSA 22.2 No. 120
 ETL Sanitation to NSF 7



In Accordance with
AHRI Std 1200

DOE 2017
 Energy Efficiency
 Compliant

Important Notes:

- 1) ELECTRICAL NOTE: If GFCI is required, a GFCI breaker MUST be used in lieu of a GFCI receptacle
 - 2) Units are supplied with levelers. They must be adjusted during installation to ensure the unit is level and plumb. Dimensions reflect levelers extended 1 1/4"
- ⚠ WARNING:** This product can expose you to chemicals, including Urethane (Ethyl Carbamate), which are known to the State of California to cause cancer and birth defects or other reproductive harm. For more information go to www.P65Warnings.ca.gov.