

Specification Sheet

Short Form Specifications

Blendport worktables, Budget series, model _____.
Top to be constructed of heavy gauge type 430 stainless steel with 1½" roll on front, 4½" backsplash, and sides turned down 90°. Open front with 1¼" O.D., stainless steel tubular crossbracing on sides and rear. Top reinforced with welded hat channels and sound deadened. Constructed with uni-lok® patented gusset system with the gussets recessed into the hat channels to reduce lateral movement. Legs to be 1½" O.D. stainless steel tubing, with stainless steel gussets and 1" stainless steel adjustable bullet feet.



*worktable with backsplash
and tubular base
—shown with optional drawer*

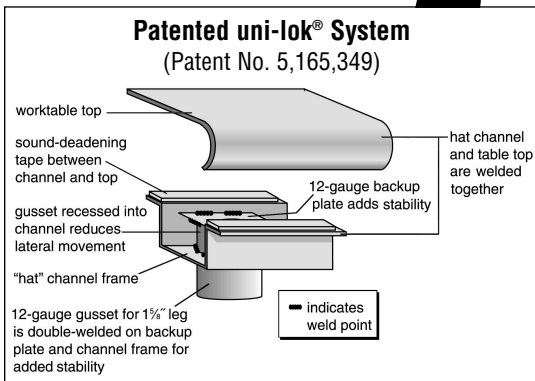

Item No.: _____
Project No.: _____
S.I.S. No.: _____

Worktables with Backsplash and Stainless Steel Tubular Base —Budget Series

MODELS:

- | | |
|---|---|
| <input type="checkbox"/> BPT-2424STB-BS | <input type="checkbox"/> BPT-3024STB-BS |
| <input type="checkbox"/> BPT-2430STB-BS | <input type="checkbox"/> BPT-3030STB-BS |
| <input type="checkbox"/> BPT-2436STB-BS | <input type="checkbox"/> BPT-3036STB-BS |
| <input type="checkbox"/> BPT-2448STB-BS | <input type="checkbox"/> BPT-3048STB-BS |
| <input type="checkbox"/> BPT-2460STB-BS | <input type="checkbox"/> BPT-3060STB-BS |
| <input type="checkbox"/> BPT-2472STB-BS | <input type="checkbox"/> BPT-3072STB-BS |
| <input type="checkbox"/> BPT-2484STB-BS | <input type="checkbox"/> BPT-3084STB-BS |
| <input type="checkbox"/> BPT-2496STB-BS | <input type="checkbox"/> BPT-3096STB-BS |

Tabletop

- Patented uni-lok® gusset system (patent #5,165,349): gussets are recessed into hat channel, reducing lateral movement.
- Top reinforced with welded-on hat channel.
- Sound-deadened between top and channels.
- 4½" (114mm)-high 90° backsplash with 1" (25mm) turn at 90°.
- 1½" (38mm)-diameter 180° rolled edge on front. Ends are turned down 90°, providing for flush installations when required.
- Heavy gauge type 430 polished stainless steel.

Crossbracing—1¼" (38mm)-diameter

- Heavy gauge stainless steel.
- Aluminum castings join crossbraces, legs and rear brace.

Legs—1½" (41mm)-diameter

- Tables 96" (2438mm) and longer come with six legs or more.
- Heavy gauge stainless steel.
- 1" (25mm) adjustable stainless steel feet*.

* Optional casters available. Consult factory.



Item No.:	_____
Project No.:	_____
S.I.S. No.:	_____

Worktables with Backsplash and Stainless Steel Tubular Base —Budget Series

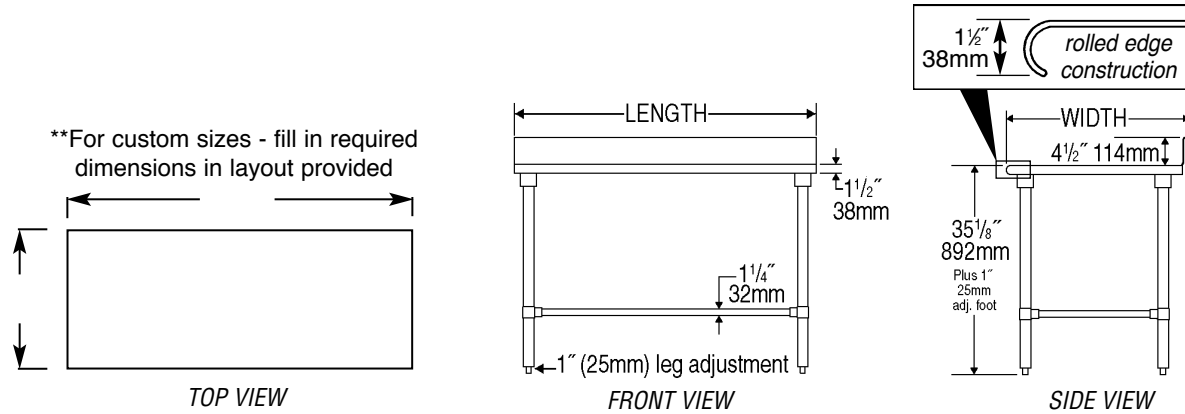

model #	# of legs	width		length		weight	
		in.	mm	in.	mm	lbs.	kg
<i>BPT-2424STB-BS</i>	4	24"	610	24"	610	41	18.6
<i>BPT-2430STB-BS</i>	4	24"	610	30"	762	46	20.9
<i>BPT-2436STB-BS</i>	4	24"	610	36"	914	51	23.1
<i>BPT-2448STB-BS</i>	4	24"	610	48"	1219	61	27.7
<i>BPT-2460STB-BS</i>	4	24"	610	60"	1524	71	32.2
<i>BPT-2472STB-BS</i>	4	24"	610	72"	1829	81	36.7
<i>BPT-2484STB-BS</i>	4	24"	610	84"	2134	91	41.3
<i>BPT-2496STB-BS</i>	6	24"	610	96"	2438	101	45.8
<i>BPT-3024STB-BS</i>	4	30"	762	24"	610	45	20.4
<i>BPT-3030STB-BS</i>	4	30"	762	30"	762	51	23.1
<i>BPT-3036STB-BS</i>	4	30"	762	36"	914	56	25.4
<i>BPT-3048STB-BS</i>	4	30"	762	48"	1219	66	29.9
<i>BPT-3060STB-BS</i>	4	30"	762	60"	1524	76	34.5
<i>BPT-3072STB-BS</i>	4	30"	762	72"	1829	86	39.0
<i>BPT-3084STB-BS</i>	4	30"	762	84"	2134	96	43.6
<i>BPT-3096STB-BS</i>	6	30"	762	96"	2438	106	48.1