



Project _____

Item No. _____

Quantity _____

F1400 Conveyor Finishing Oven



F1400 FINISHING OVEN

High-Speed Finishing Excellence

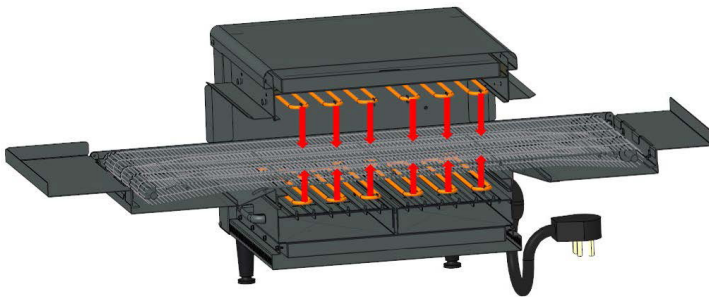

EXTERIOR CONSTRUCTION

- 430 Stainless Steel exterior
- Cool-to-touch exterior, all surfaces below 55°C
- Ultra-Quiet at a maximum 50dB sound level
- Counter-mount or with 4-inch adjustable legs (included)
- Front-facing full color 2.8-inch touchscreen display

INTERIOR CONSTRUCTION

- 18.5-inch fully insulated 304 stainless steel heating chamber
- Independent quick-heating top and bottom infrared elements

STANDARD FEATURES

- UL listed ventless operation for re-thermalization of pre-cooked product†
- Intuitive front-facing touch control can store 4-programmable recipe settings
- 38.6-in L x 14.6-in W conveyor belt assembly accommodates up to 14-inch pizzas
- Left or right feed conveyor belt direction changeable with control settings
- Includes two 4-inch conveyor extensions
- Stackable up to 3-high (stacking kit required)†
- 6-ft cord and plug
- 1 year Parts and Labor Warranty
- Applications include:
 - Melting cheese in as little as 20-seconds
 - Melting toppings and finishing foods like potato skins, soup, and nachos
 - Toasting buns and bread
 - Thermalizing frozen or fresh foods like appetizers, french fries, and pizza

STANDARD OPTIONS & ACCESSORIES

- Stacking kit for double or triple stack assembly (OVNTN-STK-16)
- Dozens of other accessory options available

CERTIFICATIONS



† Ventless certification is for pre-cooked food products being re-heated and/or re-thermalized only. This product is not certified for cooking “fatty raw proteins”. Consult local HVAC codes and authorities to ensure compliance with ventilation requirements. Ultimate ventless allowance is dependent upon AHJ approval, as some jurisdictions may not recognize the UL certification or application. If you have questions regarding ventless certifications or local codes, please email connect@ventionovens.com.

See ventionovens.com/patents for a complete list of applicable U.S. and international patents



OventionOvens.com | 855.298.6836 | connect@ventionovens.com
 Search “Ovention” to download our app.



DOC# F1400 • Revision 2/2022

Specifications are subject to change without notice and are not intended for installation purposes.



F1400 Conveyor Finishing Oven

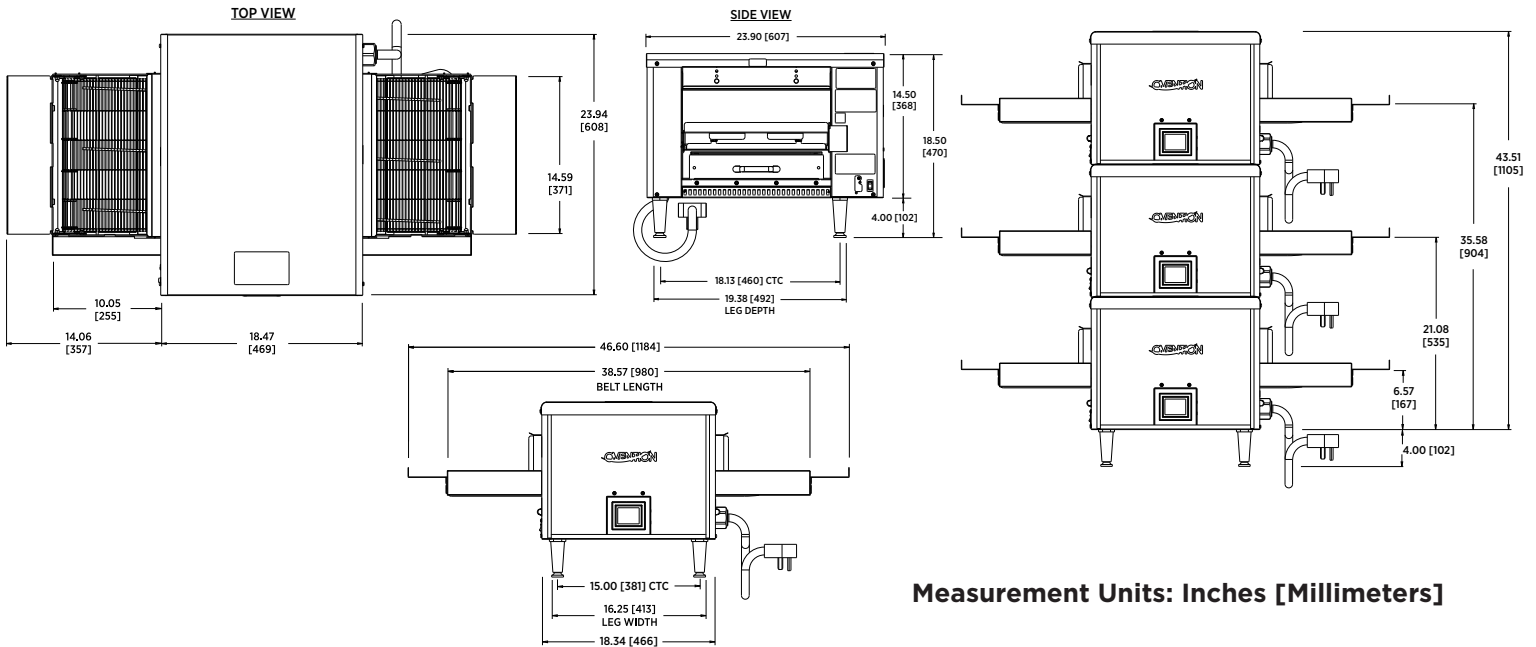

Measurement Units: Inches [Millimeters]

DIMENSIONS		
HEIGHT	18.50"	470 mm
WIDTH	46.60"	1184 mm
DEPTH	23.90"	607 mm
WEIGHT	110 lb.	79 kg
CAVITY DIMENSIONS		
HEIGHT	4"	102 mm
WIDTH	18.50"	470 mm
DEPTH	14.60"	371 mm
MINIMUM CLEARANCE		
LEFT/RIGHT/BACK	1/1/1"*	25/25/25 mm*
SHIPPING INFORMATION		
CUBE (LxWxH)	55 x 34 x 32"	1400 x 860 x 813mm
SHIPPING WT.	175 lb.	79 kg
FREIGHT CLASS	175	
POINT OF ORIGIN	Sturgeon Bay, WI, USA	

ELECTRICAL SPECIFICATIONS			
US/CANADA 1-ph	208-240 VAC, 60 Hz, 1-ph, 25/29 Amps, cULus, NEMA 6-50P and cord - standard	208V Operation Max Power: 5.2kW Heater Power: 5.2kW	 NEMA 6-50
		240V Operation Max Power: 7.0kW Heater Power: 6.9kW	
US/CANADA 3-ph	208-240 VAC, 60 Hz, 3-ph, 21/24 Amps, cULus, NEMA 6-30P and cord	208V Operation Max Power: 4.3kW Heater Power: 4.3kW	 NEMA 6-30
		240V Operation Max Power: 5.8kW Heater Power: 5.7kW	

SHORT FORM SPECIFICATIONS

Provide Ovention F1400 Conveyor Finishing Oven, countertop, one 38.6" long x 14.6" wide belt, 18.5" cook chamber, independently controlled top and bottom infrared elements, touch screen display, cool to touch 430 ss exterior, 304 ss interior, 4" adjustable legs, Made in USA, cULus, UL EPH Classified, ANSI/NSF 4.

*7" clearance required for combustible surfaces, double and triple stack required clearances vary.

Due to periodic changes in designs, methods, procedures, policies and regulations, the specifications contained in this sheet are subject to change without notice. While Ovention® exercises good faith efforts to provide information that is accurate, we are not responsible for errors or omissions in information provided or conclusions reached as a result of using the specifications. By using the information provided, the user assumes all risks in connection with such use.

