

C 33F/N

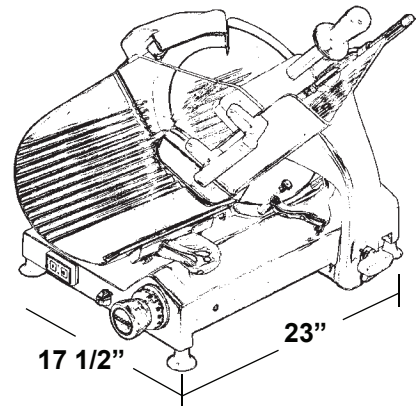

This slicer is NSF8-2010 approved, to grant food protection and sanitation requirements for the materials, design and construction. The highest degree of protection against bacteria proliferation.

- GEAR driven transmission
- ON/OFF one touch s/s switches with LED flush with slicer casting
- Removable parts for cleaning: blade cover, product holder plate, aluminium meat grip, Stainless Steel slice deflector
- Fast - no tools removable meat grip
- Blade with NARROW BAND of chromium-plated hardened steel
- 45° inclined blade
- Turning aside and REMOVABLE sharpener
- Dual action sharpener
- Fixed ring guard
- Interlock on gauge plate on zero position
- Big size product-holder plate
- Readily removable transparent Plexiglass Protection at product-holder plate
- High reliability of all elements
- New design with large spaces



PROFESSIONAL USE

Model	Blade	Drive	HP	Volt	Cut thickness	Slicing capacity	Pounds
	∅ inches				inches	inches	
C 33F/N	13"	Gear	1/2	120/60/1 230/50/1 400/50/3	0 - 9/16"	□ 10 2/3"x6 1/4" ○ 9 3/8"	95 lbs

OMAS
 Info@omas1949.com
 www.omas1949.com
 (786) 409-7052

OMAS
 Food technology
 solutions