



Project: _____

Item: _____

Quantity: _____

Date: _____

Models Length

<input type="checkbox"/> 28-ST-L/S	28 3/8"
<input type="checkbox"/> 36-ST-L/S	36 3/8"
<input type="checkbox"/> 50-ST-L/S	50 3/8"
<input type="checkbox"/> 60-ST-L/S	60 3/8"
<input type="checkbox"/> 66-ST-L/S	66 3/8"
<input type="checkbox"/> 74-ST-L/S	74 3/8"
<input type="checkbox"/> 84-ST-L/S	84 3/8"
<input type="checkbox"/> 96-ST-L/S	96 3/8"
<input type="checkbox"/> 144-ST-L/S	144 3/8"

Standard Features

- ✓ 30" wide 14 gauge stainless steel top
- ✓ Open Storage Base
- ✓ 5" Locking Swivel Casters
- ✓ Cam Operated Line-up Locks

66-ST-L shown with option: (A) Beaded, stainless steel tray slide.



- **Most versatile counters, add the options you need!**
- **Easy to clean, low maintenance**
- **12' (144-ST) unit can be made into a complete reimbursable line.**

Specifications

Top - Top to be 30" wide and fabricated from a minimum of 14 ga. stainless steel with square turnaround on all sides and corners fully welded, ground and polished. Top to have #4 satin finish and with all edges having a #7 hi-lite finish.

Body (S) - Uni-body structure, fabricated from 18 gauge stainless steel, welded ground and polished. Interior reinforced with 12 gauge galvanized uprights to support shelving and a 20 gauge steel bottom.

Body (L) - Standard grade laminate to cover all sides of an 18 gauge steel uni-body structure. Interior reinforced with 12 gauge galvanized uprights to support shelving and a 20 gauge steel bottom. Corners and bottom edge provided with 1/2 stainless steel trim strips.

Options

Top Options

- Height other than std. 36" (specify____)
- (FF) End Drop Shelf

Above the Top

- (F) Overshelf
- (GA) Sloped Front Protector, Adjustable
- (GAG) Sloped Front Protector – Adjustable – Glass Top Shelf
- (GC) Sloped Front Protector, Glass Clips
- (GCG) Sloped Front Protector – Glass Clips – Glass Top Shelf
- (M) Buffet Shield Single Service Hinged
- (N) Buffet Shield Double Service Hinged
- (GTS) Glass Top Shelf for Protector or Buffet Shield
- (I) 2 tier Display Shelf, single service
- (I2) 2 tier Display Shelf, double service
- (RR) LED Lights

Tray Slide/Cutting Boards

- (A) Beaded, stainless steel tray slide
- (B) Flat Surface, stainless steel tray slide
- (C) Tubular stainless steel tray slide
- (D) 8" wide Stainless Steel cutting board
- (E) 8" wide Richlite® composite cutting board

Base Options

- (EB) Enclosed Base – no under storage
- (Y) Hinged Doors
- (BB) Heated Storage Base
- (CC) Refrigerated Storage Base (36 high units only)
- (MM) Vertical Trim Strips
- (SS) Stainless Steel Legs
- (OP) Offset Panels
- S/S Toe Kick

Plumbing & Electrical Options

- (DD) Convenience outlet, flush

Solid Top Table
Laminate Panel (L) or Stainless Steel (S)

A.I.A. File No. 00-0-00

SIS No. 00-0-00

REV 10/25/19 - Printed in the U.S.A.



LTI, Inc.
1947 Bill Casey Parkway (888) 584-2722
Jonesboro, GA 30236 lowtempind.com

Approvals: _____

Solid Top Table

Laminate Panel (L) or Stainless Steel (S)



Solid Top Table
Laminate Panel (L) or Stainless Steel (S)

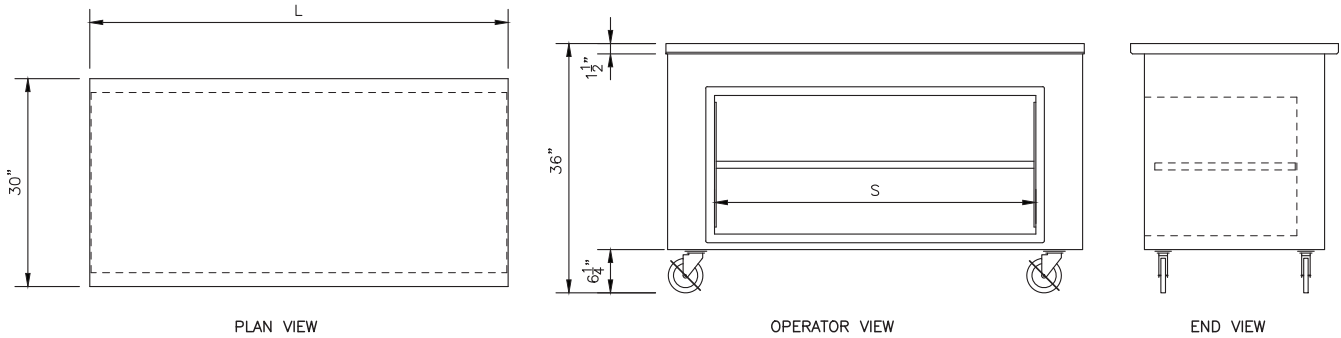

Model	L	S	Approx. Ship Weight
28-ST	28 ^{3/8"}	N/A	205 lbs.
36-ST	36 ^{3/8"}	15"	220 lbs.
50-ST	50 ^{3/8"}	36"	260 lbs.
60-ST	60 ^{3/8"}	46"	300 lbs.
66-ST	66 ^{3/8"}	46"	320 lbs.
74-ST	74 ^{3/8"}	(2) 28"	340 lbs.
84-ST	84 ^{3/8"}	28" & 36"	360 lbs.
96-ST	96 ^{3/8"}	28" & 46"	380 lbs.
144-ST	144 ^{3/8"}	(2) 46"	750 lbs.

Décor Options (Contact Factory)

- Vinyl Graphic Wrap
- Body Decal
- Canopy (specify style & color)
- Over-structure with signage & lights
(specify _____)
- Stand Off Panel
(specify materials _____)

We reserve the right to change specifications and product design without notice. Such revisions do not entitle the buyer to corresponding changes, improvements, additions or replacement for previously purchased equipment.

All equipment to be built in accordance with the Underwriters Laboratories, Inc. and the National Sanitation Foundation, Inc. standards and shall bear the Underwriters Laboratories, Inc. listing label for safety and the Underwriters Laboratories classification label for sanitation.

A.I.A. File No. 00-0-00

SIS No. 00-0-00

REV 10/25/19 - Printed in the U.S.A.

LTI, Inc.
1947 Bill Casey Parkway
Jonesboro, GA 30236

(888) 584-2722
lowtempind.com



Changing
how food is served.™