

# UNDERCOUNTER REFRIGERATOR

## Model: SW27N-U

Natural Refrigerant R-290 Model

### 27" Undercounter Refrigerator with Solid Door



ENERGY STAR® Qualified Commercial Refrigerator

Stainless steel front, top and end panels, aluminum back and interior.



## Options and Accessories

(upcharge and lead times may apply)

Stainless steel interior	Stainless steel shelves
Stainless steel back	Door lock
Stacking collar	Additional epoxy coated steel shelves
Hinged glass door	
Special electrical requirements (consult factory)	

Consult factory for other model configurations, options and accessories.



Toll-Free: 800-523-7138  
Phone: 215-244-1400  
Fax: 215-244-9579

539 Dunksferry Road  
Bensalem, PA 19020  
www.continentalrefrigerator.com

Project Name:

Model Specified:

Location:

Item No:

Quantity:

AIA #:

SIS #:

## Standard Model Features

### REFRIGERATION SYSTEM

Performance rated refrigeration system

Natural, environmentally safe, high efficiency R-290 refrigerant<sup>1</sup>

Automatic, hot gas condensate evaporator

Non-corrosive, plasticized fin evaporator coil

Easily serviceable, back mounted compressor

### CABINET ARCHITECTURE

2" non-CFC polyurethane foam insulation

Smooth, polished chrome door handle

Spring loaded, self closing door

Magnetic snap in Santoprene™ door gasket

Heavy duty, epoxy coated steel shelf

Completely enclosed, vented and removable case back

1 3/8" diameter plate casters (factory installed)

### MODEL FEATURES

Field rehingeable door

Off-cycle defrost

Electronic controller with digital display & hi/low alarm

2" high, bottom mounted front breather air divider

<sup>1</sup> R-290 refrigerant meets all federal and state regulatory requirements.

APPROVAL:

# Model Specifications

## DIMENSIONAL DATA

Net Capacity (cubic feet)	7.4 (210 cu l)
Width, Overall (inches)	27 1/2 (699 mm)
Depth, Overall (inches) (including handle & bumpers)	32 3/16 (818 mm)
Height, Overall (inches) (including 1 3/8" plate casters)	31 13/16 (808 mm)
Shelf Area (square feet)	3.5 (0.3 sq m)
No. of Shelves	1
No. of Doors	1
Interior Depth (inches)	See Drawing
Interior Height (inches)	26 1/4 (667 mm)
Interior Width (inches)	24 1/2 (622 mm)

## REFRIGERANT DATA

Condensing Unit Size (H.P.)	1/5
Capacity (BTU per hour)*	1625

## ELECTRICAL DATA

Voltage (International)	115/60/1 (220/50/1)
Total Amps (International)	2.5 (2.2)
10 ft. Cord/Plug [attached] (International)	Yes (No)

## SHIPPING DATA

Weight (pounds)	165 (75 kg)
Height - Crated (inches)	43 1/4 (1099 mm)
Width - Crated (inches)	35 1/2 (902 mm)
Depth - Crated (inches)	37 1/4 (946 mm)

\* Rating @ +25°F evaporator, 90°F ambient  
Figures in parentheses reflect metric equivalents rounded to the nearest whole unit.



Equipped with one NEMA-5-15P Plug  
(varies by country)

# Model Plan Views

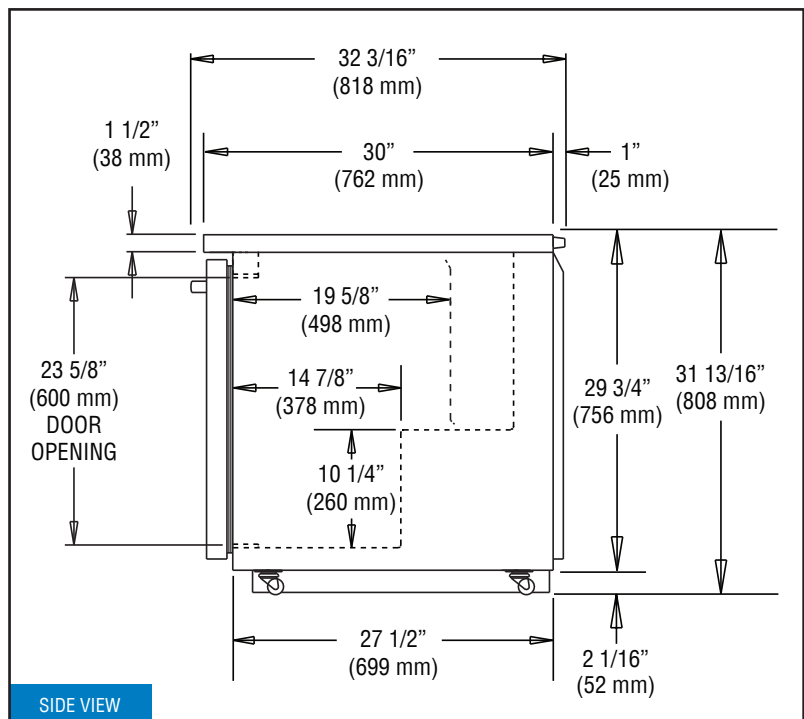
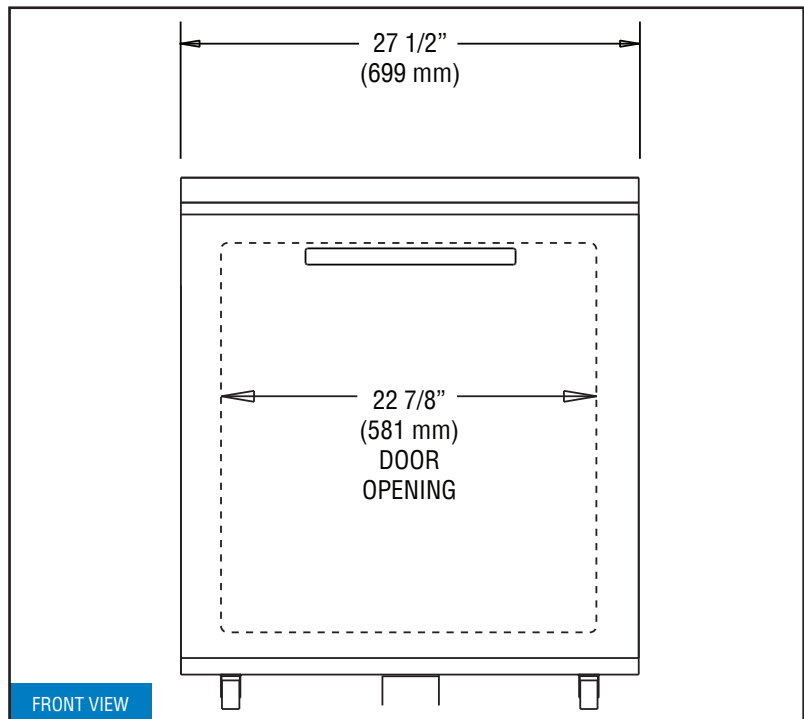

**NOTE:** For proper operation, the area under and in front of the cabinet **must** not be obstructed in any way.

**Continental**  
Refrigerator

Toll-Free: 800-523-7138  
Phone: 215-244-1400  
Fax: 215-244-9579

539 Dunksferry Road  
Bensalem, PA 19020  
[www.continentalrefrigerator.com](http://www.continentalrefrigerator.com)

Due to our continued efforts in developing innovative products, specifications subject to change without notice.



© Copyright 2021. Continental Refrigerator.  
A Division of National Refrigeration & Air Conditioning Products, Inc.

REVISED: 5/16/2022