

ITEM #



MS SERIES

MS82-46W Wood-Fired Ovens

Experience a level of quality that is Italian inspired but manufactured in the U.S. Marra Forni Brick ovens are the combination of true artisan workmanship and modern American manufacturing technology, and design innovation. Each oven is hand-made, brick-by-brick, using proprietary materials and the same time proven techniques that the traditional Italian Brick Masons have used for generations.

Offered in a variety of sizes based upon production needs and space limitations, the MS Series is designed to fit into a specific space configuration while offering all the design features and performance benefits of our traditional Neapolitan brick oven solutions. Featuring a static cooking deck, these wood-fired ovens enhance the dining experience. Whether free-standing in a kitchen or enclosed within a wall or other structure, these ovens are designed for consistent and high-volume production in a busy operation.



Standard Features

- **MarraStone® handmade dome and cooking deck construction featuring proprietary formulated high porosity refractory bricks, able to sustain temperatures exceeding 950°F.**
- **Integrated eyebrow exhaust duct designed into the structure of the oven dome, insuring effective capture and exhaust of the oven cavity.**
- **Redundant back-up manual control recalls last cooking temperature to minimize any oven down time.**
- **Approved for use with direct venting. Pending local jurisdictional approval.**
- **Easy to clean static refractory brick cooking deck.**
- **Includes 1¼" thick black granite mantle ledge.**
- **Superior cooking performance and recovery based upon natural convective airflow within the brick oven dome, and the heat retention of custom formulated refractory bricks and oven insulation.**
- **Heavy-duty welded steel construction.**
- **Painted matte black steel façade and heavy-duty black powder coated steel stand.**
- **Warranty: 3-year deck and dome, 1-year parts and labor.**
- **Manufactured in the USA with our commitment to quality, performance, and support.**

Cooking Deck Capacity

- 8" Pizzas: 50
- 10" Pizzas: 32
- 12" Pizzas: 18
- 16" Pizzas: 10

Total Cooking Surface: 26.19 Square Feet
(cooking deck dimensions 82" x 46")

Production capacity varies depending upon type of pizza being cooked, set temperatures and preparation methods used.

Average cook time of Neapolitan Pizza ranges from 90-120 seconds at 750-900° F. Any additional decorative flame feature will reduce the cooking surface area by 10-30%

Configuration Options (Check all that apply)

Accessory Items

- Dough Tray
- Dough Tray Lids
- Dough Tray Dolley
- Deluxe Peel Tool Kit
- Standard Peel Tool Kit
- Wall Mounted Tool Rack
- Wood Andiron

Options

- Stainless-Steel Facade
- Stainless-Steel Stand
- Powdercoating
- Tile for Facade/Upgrade
- Base Enclosure (Side Panels)
- Base Enclosure (Full Skirt Enclosure)
- Direct Ventilation (Quoted Separately)
- Exhaust Fan
- Integrated Fan Interlock
- Variable Speed Fan Control



ANSI Z83.11 CSA 1.8

MS SERIES

MS82-46W Wood-Fired Ovens

Top View

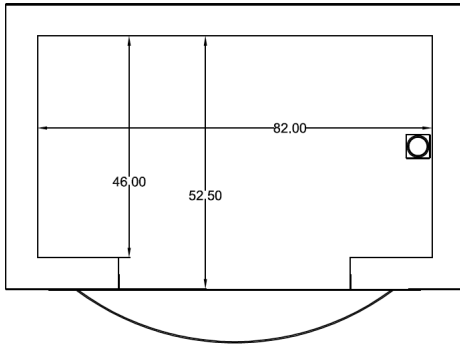

Front View

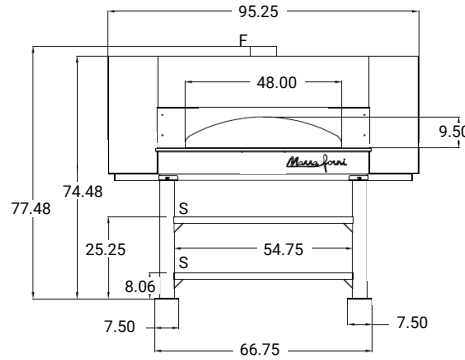

Side View

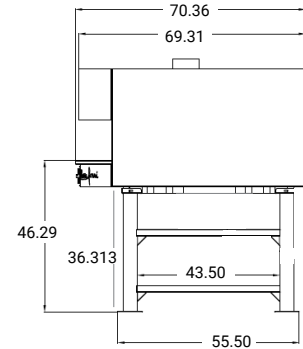

C - Controls
E - Electrical Connection Flexible Cord
F - Flue Collar

G - Gas Connection
S - Storage Shelf

Dimensions Model MS82-46W

- Exterior (H x W x D): 77.48" x 95.25" x 70.36"
- Actual Weight: 3,200 lbs.
- Shipped via Flatbed

Clearance Requirements

- 2" minimum clearance on all sides from combustible surfaces.
- 0" required from non-combustibles.

Venting Requirements

- The oven is vented through an 8" round duct collar. Ovens can be installed with a UL listed exhaust hood system or approved direct vent exhaust duct vented to the outside.
- Direct venting must be installed with a powered grease exhausted vent.
- Optional variable speed fan controller and integrated fan interlock are available.
- Cubic Feet per Minute: 150 CFM Static Pressure: 0.01" W.C.
- Ventilation is subject to local jurisdictional approval.

Due to ongoing product development and continuous improvement measures, specifications are subject to change without notice. All ovens are designed for commercial applications. All Marra Forni ovens are approved with a door which serves as a fire suppressor by completely sealing the oven cavity.