

Specification Sheet

Short Form Specifications

Blendport worktables, Deluxe series, model _____.
Top constructed of 16 gauge 300 series stainless steel with 1½" roll on front and rear, and sides turned down 90°. Open front with 1¼" O.D. galvanized tubular crossbracing on sides and rear. Top reinforced with hat channels and sound deadened. Constructed with uni-lok® patented gusset system with the gussets recessed into the hat channels to reduce lateral movement. Legs are 1½" O.D. galvanized tubing, with galvanized gussets and 1" hi-impact plastic bullet feet.



worktable with flat top and tubular base

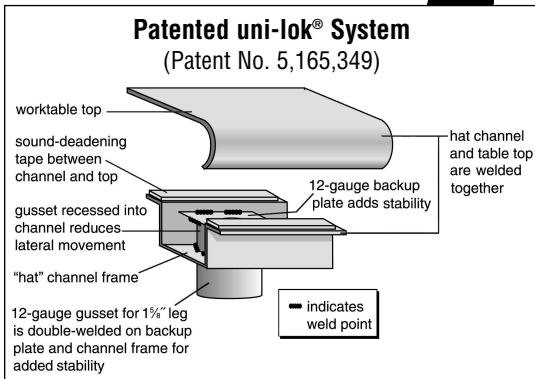

Item No.: _____
Project No.: _____
S.I.S. No.: _____

Worktables with Flat Top and Galvanized Tubular Base —Deluxe Series

MODELS:

- | | | |
|---------------------------------------|---------------------------------------|---------------------------------------|
| <input type="checkbox"/> BPT-2424GTEB | <input type="checkbox"/> BPT-2484GTEB | <input type="checkbox"/> BPT-3060GTEB |
| <input type="checkbox"/> BPT-2430GTEB | <input type="checkbox"/> BPT-2496GTEB | <input type="checkbox"/> BPT-3072GTEB |
| <input type="checkbox"/> BPT-2436GTEB | <input type="checkbox"/> BPT-3024GTEB | <input type="checkbox"/> BPT-3084GTEB |
| <input type="checkbox"/> BPT-2448GTEB | <input type="checkbox"/> BPT-3030GTEB | <input type="checkbox"/> BPT-3096GTEB |
| <input type="checkbox"/> BPT-2460GTEB | <input type="checkbox"/> BPT-3036GTEB | |
| <input type="checkbox"/> BPT-2472GTEB | <input type="checkbox"/> BPT-3048GTEB | |

Tabletop

- Patented uni-lok® gusset system (patent #5,165,349): gussets are recessed into hat channel, reducing lateral movement.
- Top reinforced with welded-on hat channel.
- Sound-deadened between top and channels.
- 1½" (38mm)-diameter 180° rolled edges on front and rear. Ends are turned down 90°, providing for flush installations when required.
- 16 gauge 300 series polished stainless steel.

Crossbracing—1¼" (38mm)-diameter

- Heavy gauge, galvanized.
- Aluminum castings join crossbraces, legs and rear brace.

Legs—1½" (41mm)-diameter

- Tables 96" (2438mm) and longer come with six legs or more.
- Heavy gauge galvanized steel.
- 1" (25mm) adjustable hi-impact plastic feet*.

* Optional casters available. Consult factory.





Item No.:	_____
Project No.:	_____
S.I.S. No.:	_____

Worktables with Flat Top and Galvanized Tubular Base —Deluxe Series

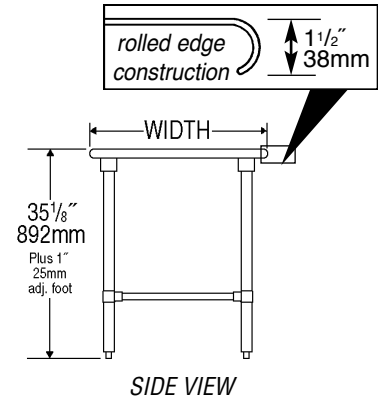
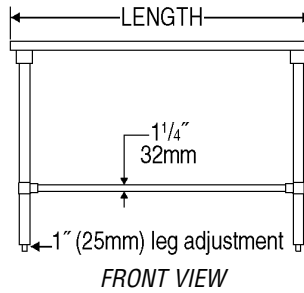
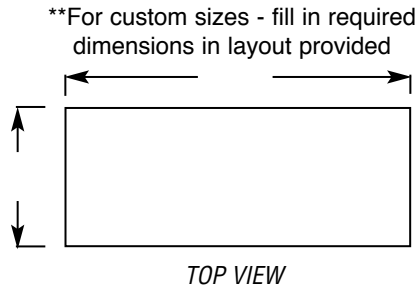

model #	# of legs	width		length		weight	
		in.	mm	in.	mm	lbs.	kg
BPT-2424GTEB	4	24"	610	24"	610	40	18.1
BPT-2430GTEB	4	24"	610	30"	762	45	20.4
BPT-2436GTEB	4	24"	610	36"	914	50	22.7
BPT-2448GTEB	4	24"	610	48"	1219	60	27.2
BPT-2460GTEB	4	24"	610	60"	1524	70	31.8
BPT-2472GTEB	4	24"	610	72"	1829	80	36.3
BPT-2484GTEB	4	24"	610	84"	2134	90	40.8
BPT-2496GTEB	6	24"	610	96"	2438	100	45.4
BPT-3024GTEB	4	30"	762	24"	610	45	20.4
BPT-3030GTEB	4	30"	762	30"	762	47	21.3
BPT-3036GTEB	4	30"	762	36"	914	53	24.0
BPT-3048GTEB	4	30"	762	48"	1219	65	29.5
BPT-3060GTEB	4	30"	762	60"	1524	77	34.9
BPT-3072GTEB	4	30"	762	72"	1829	89	40.4
BPT-3084GTEB	4	30"	762	84"	2134	101	45.8
BPT-3096GTEB	6	30"	762	96"	2438	113	51.3

BlendPort®

An Eagle Group Company
 100 Industrial Boulevard, Clayton, DE 19938-8903 USA
 Phone: 800-441-8440 • Fax: 302-653-2065

Printed in U.S.A.
 ©2020 by Eagle Group
 Rev. 05/20

Although every attempt has been made to ensure the accuracy of the information provided, we cannot be held responsible for typographical or printing errors. Information and specifications are subject to change without notice. Please confirm at time of order.