



Discover the Art of Display...



Gem Drop In Hot

Project Name: _____

Item #: _____ Quantity: _____

GEM DROP IN HOT(DRY HEAT)

MODELS: GEM DI-H800, H900, H1100, H1300, H1500, H1700, H2000

STANDARD FEATURES

- Dry hot plate
- Extra clear glass: front, top, sides glasses
- All tempered glass
- Heat lamp
- Stainless steel lower interior foam tub
- Galvanized chassis structure
- Cases ship standard unfinished front

OPTIONS

- Epoxy RAL color interior over stainless steel

Visit our website for optional RAL colors and Materials finishes.

[RAL Colors Website](#)

[Materials Brochure PDF](#)

**Oscartek® reserves the right to change, modify, discontinue, or change any features, sizes, or capacity on any model without prior notice.*

OSCARTEK®
512 South Airport Blvd., South San Francisco, CA 94080
Tel: 855.885.2400 | 650.342.2400 | Fax: 650.342.7400
sales@oscartek.com | www.oscartek.com



MODELS: GEM DI-H800, H900, H1100, H1300, H1500, H1700, H2000

GEM PLAN VIEWS

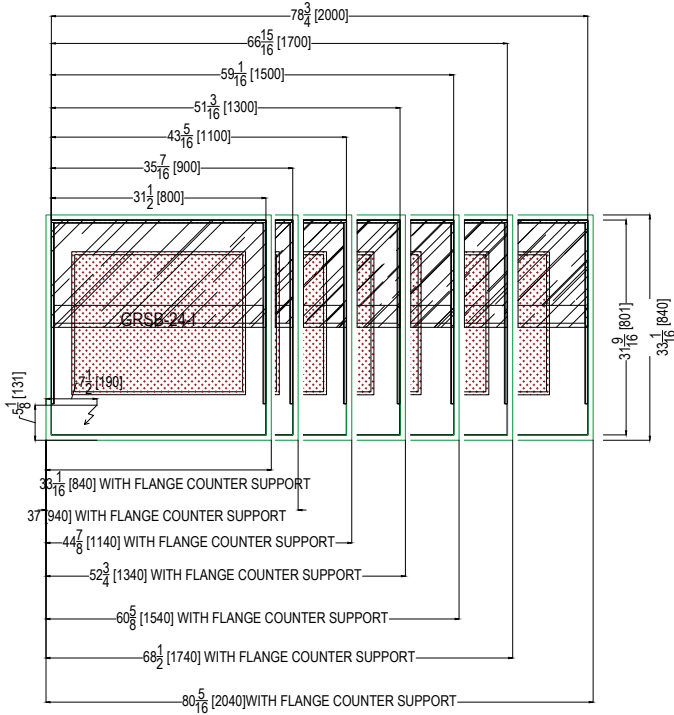

ELECTRICAL LEGEND	
⚡	POWER

GEM REAR ELEVATIONS

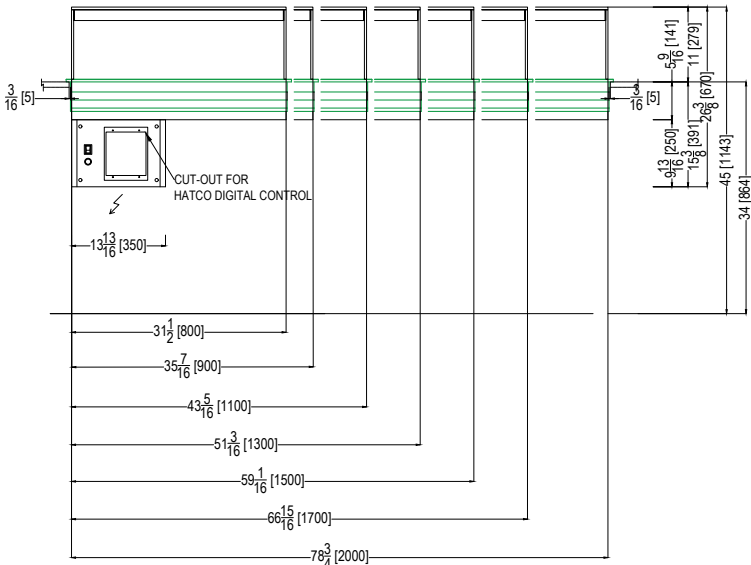

*Oscartek® reserves the right to change, modify, discontinue, or change any features, sizes, or capacity on any model without prior notice.

OSCARTEK®
512 South Airport Blvd., South San Francisco, CA 94080
Tel: 855.885.2400 | 650.342.2400 | Fax: 650.342.7400
sales@oscartek.com | www.oscartek.com



MODELS: GEM DI-H800, H900, H1100, H1300, H1500, H1700, H2000

STANDARD: GEM - 33"D SECTION VIEW

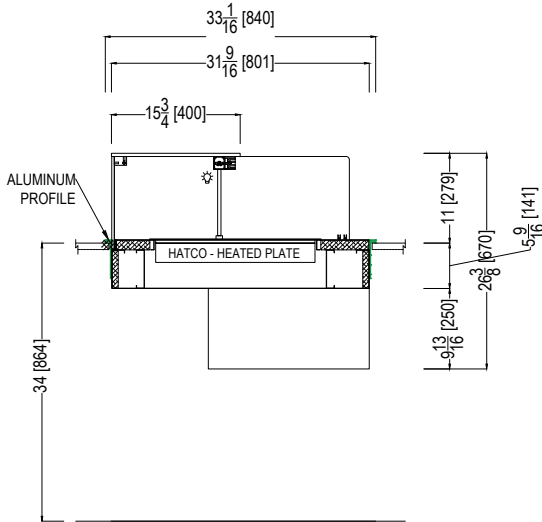

GEM DROP IN(DI) DRY HOT					
TECHNICAL FEATURES		MODELS			
		GEM DI-H800	GEM DI-H900	GEM DI-H1100	GEM DI-H1300
External Dimensions (L-D-H)	Inches	*33 1/8" - 33 1/8" - 26 3/8"	*37" - 33 1/8" - 26 3/8"	*44 7/8" - 33 1/8" - 26 3/8"	*52 3/4" - 33 1/8" - 26 3/8"
Inches-MM	MM	*840 - 840 - 670	*940 - 840 - 670	*1140 - 840 - 670	*1340 - 840 - 670
Crated Dimensions (L-D-H)	Inches	40" - 40 1/2" - 34"	44" - 40 1/2" - 34"	52" - 40 1/2" - 34"	59" - 40 1/2" - 34"
Inches-MM	MM	1016 - 1030 - 864	1117 - 1030 - 864	1320 - 1030 - 864	1498 - 1030 - 864
Operating Temperature	°F	177°F	177°F	177°F	177°F
Electric Supply	(V/Ph/Hz)	208-220/1/60	208-220/1/60	208-220/1/60	208-220/1/60
Power Consumption	HEAT LAMP (W/A)	16 / 0,1	18 / 0,1	22 / 0,1	26 / 0,1
Direct Connexion	HOT PLATE (V/W/A)	120/550/4.6 - NEMA 5-15P	120/665/5.6 - NEMA 5-15P	120/780/6.5 - NEMA 5-15P	120/885/7.4 - NEMA 5-15P
Climate Class	°F/%RH	75°F-55%RH	75°F-55%RH	75°F-55%RH	75°F-55%RH
Net Weights	Lbs	208	249	300	367
Crated Weights	Lbs	268	309	370	437

*DIMENSIONS WITH FLANGE COUNTER SUPPORT

GEM DROP IN(DI) DRY HOT					
TECHNICAL FEATURES		MODELS			
		GEM DI-H1500	GEM DI-H1700	GEM DI-H2000	
External Dimensions (L-D-H)	Inches	*60 5/8" - 33 1/8" - 26 3/8"	*68 1/2" - 33 1/8" - 26 3/8"	*80 3/8" - 33 1/8" - 26 3/8"	
Inches-MM	MM	*1540 - 840 - 670	*1740 - 840 - 670	*2040 - 840 - 670	
Crated Dimensions (L-D-H)	Inches	67" - 40 1/2" - 34"	76" - 40 1/2" - 34"	88" - 40 1/2" - 34"	
Inches-MM	MM	1702 - 1030 - 864	1930 - 1030 - 864	2235 - 1030 - 864	
Operating Temperature	°F	177°F	177°F	177°F	
Electric Supply	(V/Ph/Hz)	208-220/1/60	208-220/1/60	208-220/1/60	
Power Consumption	HEAT LAMP (W/A)	30 / 0,2	34 / 0,2	40 / 0,2	
Direct Connexion	HOT PLATE (V/W/A)	120/1000/8.3 - NEMA 5-15P	120/1220/10.2 - NEMA 5-15P	120/1330/11.1 - NEMA 5-15P	
Climate Class	°F/%RH	75°F-55%RH	75°F-55%RH	75°F-55%RH	
Net Weights	Lbs	420	513	649	
Crated Weights	Lbs	500	593	759	

*DIMENSIONS WITH FLANGE COUNTER SUPPORT

*Oscartek® reserves the right to change, modify, discontinue, or change any features, sizes, or capacity on any model without prior notice.