

DESIGNER LINE SLIM LINE REFRIGERATOR

Model: D2RSESNHD

Natural Refrigerant R-290 Model

Designer Line

2-Section Slim Line Reach-In Refrigerator with Half Doors Shallow Depth

D2RSESNHD - Stainless steel front, aluminum end panels and interior

D2RSESNHAHD - Stainless steel exterior, aluminum interior

D2RSESNSSHD - Stainless steel exterior and interior



Options and Accessories

(upcharge and lead times may apply)

Stainless steel case back	Casters
Additional epoxy coated steel shelves	Custom laminates
Chrome or stainless steel shelves	Special electrical req. (consult factory)
Standard depth (consult factory)	Correctional Facility Options
Full doors	• One way security screws
Hinged glass door (consult factory)	• Locking hasp (lock not included)
Rehinging of doors (consult factory)	• Stainless steel mesh cover
Wine rack	• Coverless hinges

Consult factory for other model configurations, options and accessories.

Continental[®]
Refrigerator

Toll-Free: 800-523-7138
Phone: 215-244-1400
Fax: 215-244-9579

539 Dunksferry Road
Bensalem, PA 19020
www.continentalrefrigerator.com

Project Name:

Model Specified:

Location:

Item No:

Quantity:

AIA #:

SIS #:

Standard Model Features

REFRIGERATION SYSTEM

Self contained, performance rated refrigeration system (coil in the cabinet zone)

Natural, environmentally safe, high efficiency R-290 refrigerant¹

Automatic, electric condensate evaporator

Expansion valve system

CABINET ARCHITECTURE

2" non-CFC polyurethane foam insulation

Smooth, polished chrome workflow door handles

Cam action, lift off hinges

Self-closing doors

Magnetic snap-in Santoprene™ door gaskets

Cylinder lock in each door

Heavy duty pilaster strips

Heavy duty, epoxy coated steel shelves

Adjustable 6" stainless steel legs

MODEL FEATURES

LED interior lighting

Electronic controller with digital display & hi-low alarm

Off-cycle defrost

Cabinet upper side panels and refrigeration "plug" system can be removed and reinstalled at job site

Will accommodate 12 x 20 pans

¹ R-290 refrigerant meets all federal and state regulatory requirements.

APPROVAL:

Model Specifications

DIMENSIONAL DATA

Net Capacity (cubic feet)	24 (680 cu l)
Width, Overall (inches)	36 1/4 (921 mm)
Depth, Overall (inches) (including handles)	29 1/4 (743 mm)
Depth (inches) (less doors)	25 7/8 (657 mm)
Depth (inches) (doors open 90°)	41 1/4 (1048 mm)
Clear Door Width (inches)	12 7/8 (327 mm)
Clear Half Door Height (inches)	28 1/2 (724 mm)
Height, Overall (inches) (including 6" legs)	83 1/4 (2115 mm)
Number of Doors	4
Number of Shelves	6
Shelf Area (square feet)	24.4 (2.3 sq m)

REFRIGERANT DATA

Condensing Unit Size (H.P.)	1/3+
Capacity (BTU per hour)*	2190

ELECTRICAL DATA

Voltage (International)	115/60/1 (220/50/1)
Feed Wires (including ground)	3
Total Amps (International)	8.1 (4.9)
10 ft. Cord/Plug [attached] (International)	Yes (No)

SHIPPING DATA

Height - Crated (inches)	85 1/2 (2172 mm)
Width - Crated (inches)	42 (1067 mm)
Depth - Crated (inches)	42 (1067 mm)
Volume - Crated (cubic feet)	84 (2379 cu l)
Weight Std - Crated (pounds)	430 (195 kg)
Weight SS - Crated (pounds)	520 (236 kg)

* Rating @ +25°F evaporator, 90°F ambient
Figures in parentheses reflect metric equivalents rounded to the nearest whole unit.



Equipped with one NEMA-5-15P Plug
(varies by country)

Model Plan Views

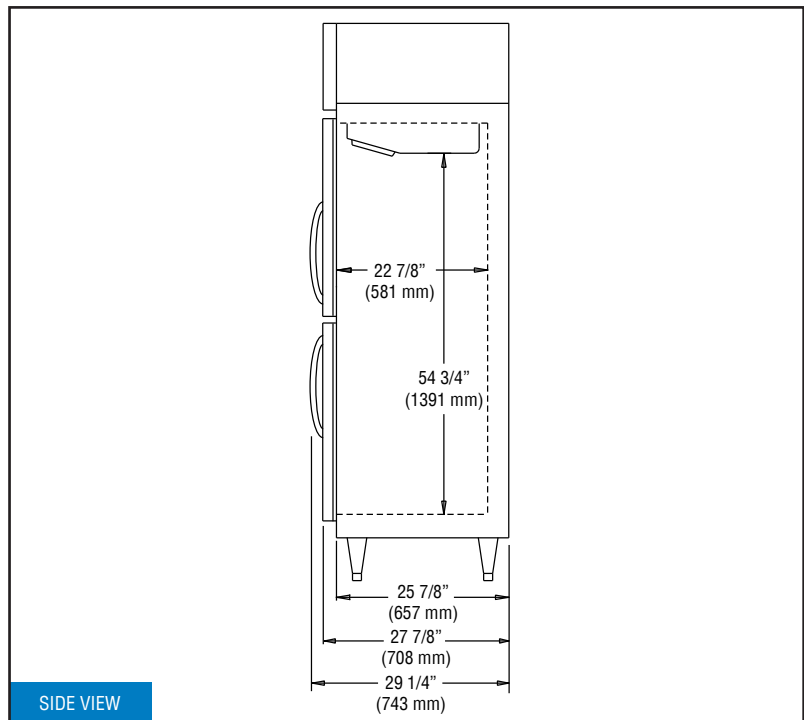
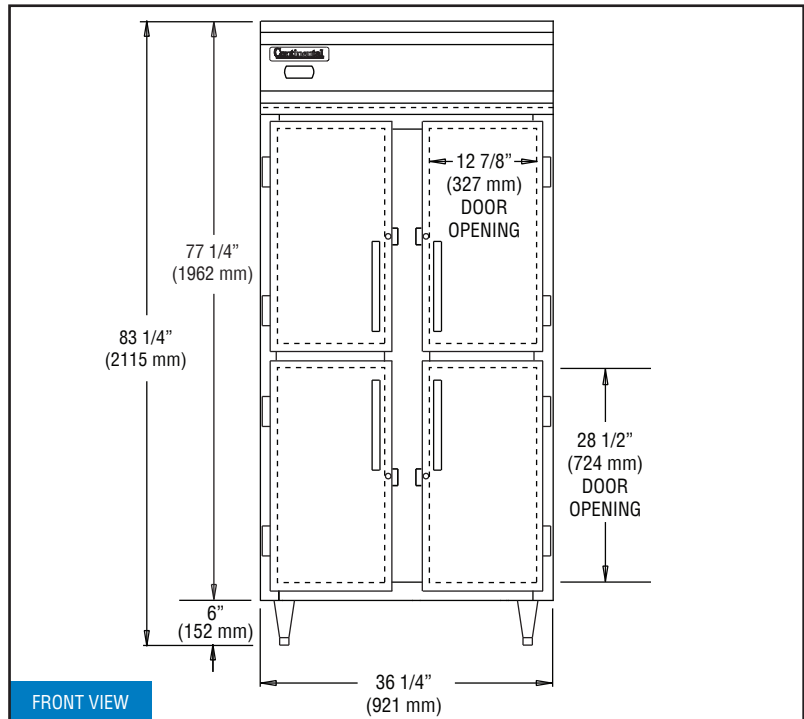

IMPORTANT NOTE: If the cabinet is located directly against a wall and/or under a low ceiling, a minimum clearance of 12" is required on top and 3" on sides and rear.

Continental
Refrigerator

Toll-Free: 800-523-7138
Phone: 215-244-1400
Fax: 215-244-9579

539 Dunksferry Road
Bensalem, PA 19020
www.continentalrefrigerator.com

Due to our continued efforts in developing innovative products, specifications subject to change without notice.

