



Gala Cheese & Charcuterie with custom finish

GALA CHEESE & CHARCUTERIE

MODELS: GALA CC700, CC1400, CC1400-2T, CC2100, CC2100-2T, CC2800

BACK WINDOW MODELS: GALA CC770BW, CC1370BW, CC1970BW

PASS THROUGH MODELS: GALA CC770PT, CC1370PT, CC1970PT

STANDARD FEATURES

- Solid Sides
- Dual Medium Temperature Version with intermediate double glass divider
- Triple pane glass premium door
- Steel load bearing structure
- 3000°K LED lighting with dimmer switch
- Touch Control
- Ventilated cooling
- interior vertical shelf support in stainless steel
- adjustable feet
- standard steel 304A
- stainless steel interior and exterior
- Stainless steel shelves adjustable in height and hanging racks
- programmed automatic electric defrost
- Approvals: cETLus, ETL sanitation, certified CE
- Remote condensing unit
- Condensate evaporator pan
- **Back Window & Pass Through:** glass shelving, glass sides
- **Back Window:** rear glass side
- **Pass Through:** rear glass door

Visit our website for optional RAL colors and Materials finishes.

[RAL Colors Website](#)

[Materials Brochure PDF](#)

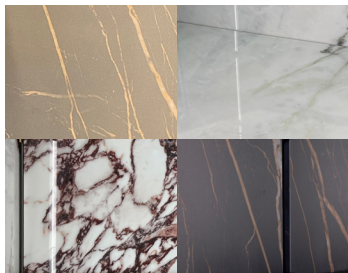



Examples of optional 6mm thick stone back panel behind shelf. For full selection see our Materials Brochure.

OPTIONS

- RAL Color Option powder coated door handles exterior and interior over stainless
- Front wood laminate door and handles
- interior shelf trim
- 6mm thick stone back panel behind shelf
- Glass Sides
- Wooden exterior
- top door and interior shelf trim
- Bottom mount condensing unit
- Top mounted condensing unit
- water cooled
- central refrigeration rack
- 60 Hz components UL
- 6mm thick stone back panel behind shelf
- Glass Sides
- Narrow Depth
- front breathing available for 1400L - 2800L models

*Oscartek® reserves the right to change, modify, discontinue, or change any features, sizes, or capacity on any model without prior notice.

MODELS: GALA CC700, CC1400, CC1400-2T, CC2100, CC2100-2T, CC2800
BACK WINDOW MODELS: GALA CC770BW, CC1370BW, CC1970BW
PASS THROUGH MODELS: GALA CC770PT, CC1370PT, CC1970PT

ELECTRICAL LEGEND	
	REFRIGERATION LINES
	DRAIN
	POWER

GALA CHEESE & CHARCUTERIE
PLAN VIEWS

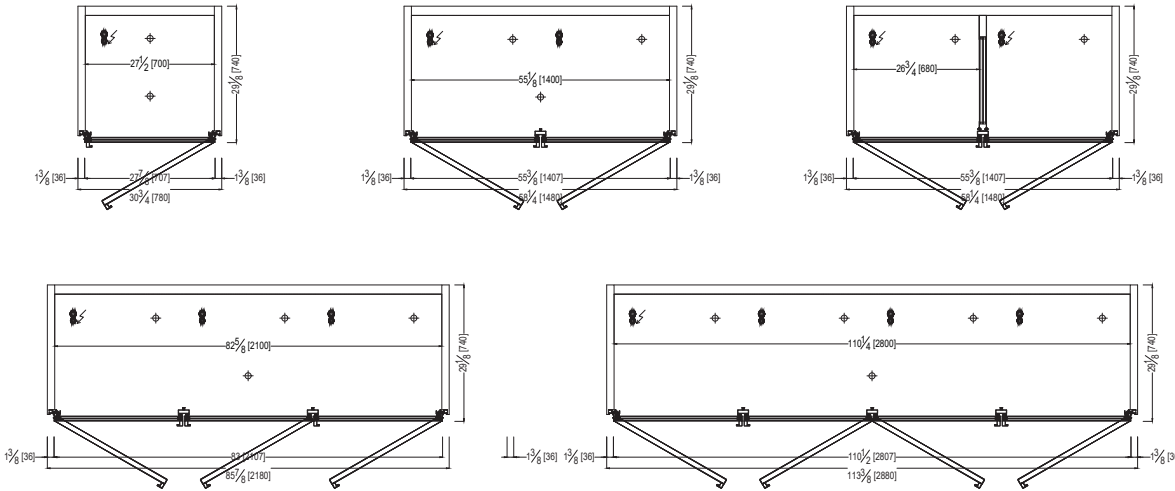

BACK WINDOW
PLAN VIEWS

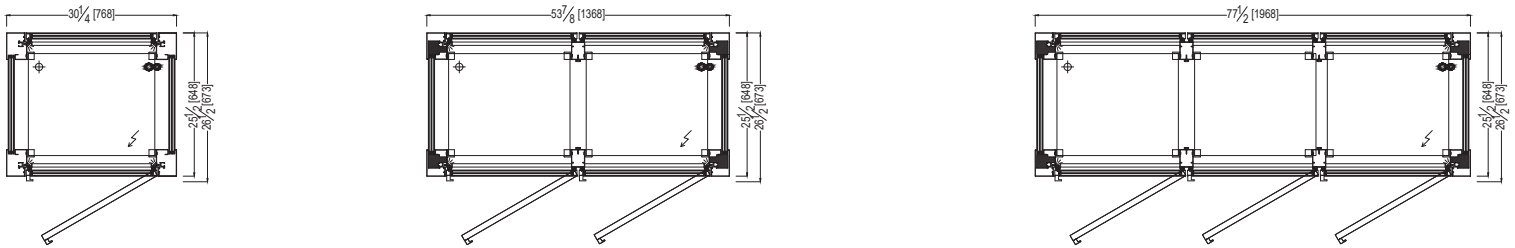

PASS THROUGH
PLAN VIEWS

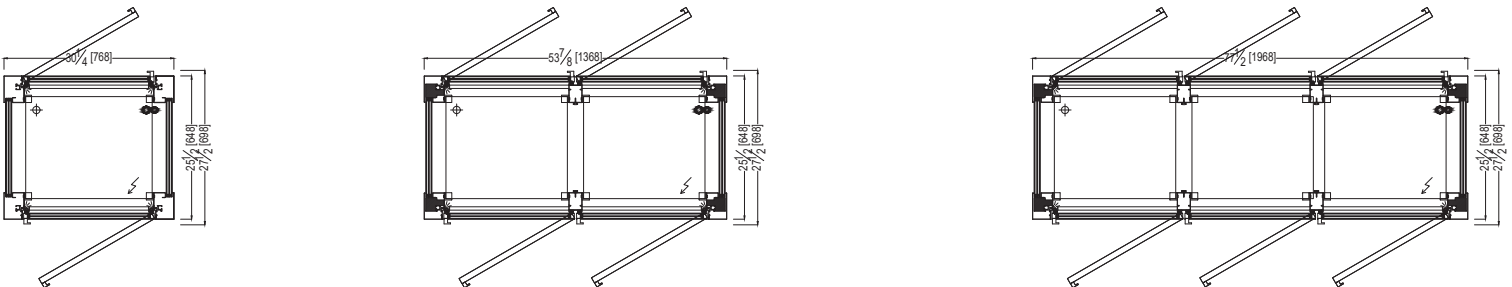

*Oscartek® reserves the right to change, modify, discontinue, or change any features, sizes, or capacity on any model without prior notice.

Discover the Art of Display...

MODELS: GALA CC700, CC1400, CC1400-2T, CC2100, CC2100-2T, CC2800

BACK WINDOW MODELS: GALA CC770BW, CC1370BW, CC1970BW

PASS THROUGH MODELS: GALA CC770PT, CC1370PT, CC1970PT

GALA CHEESE & CHARCUTERIE
FRONT ELEVATIONS

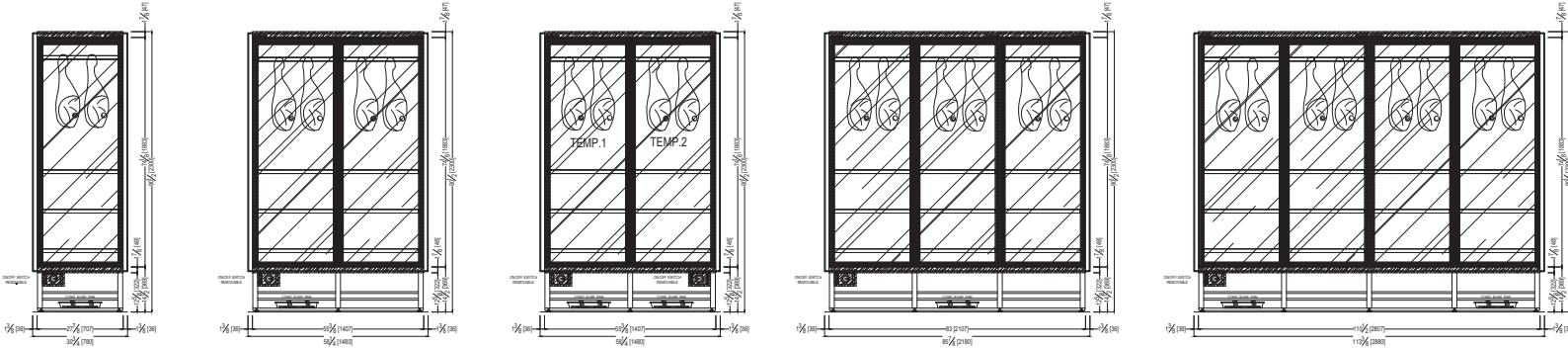

BACK WINDOW & PASS THROUGH
FRONT ELEVATIONS

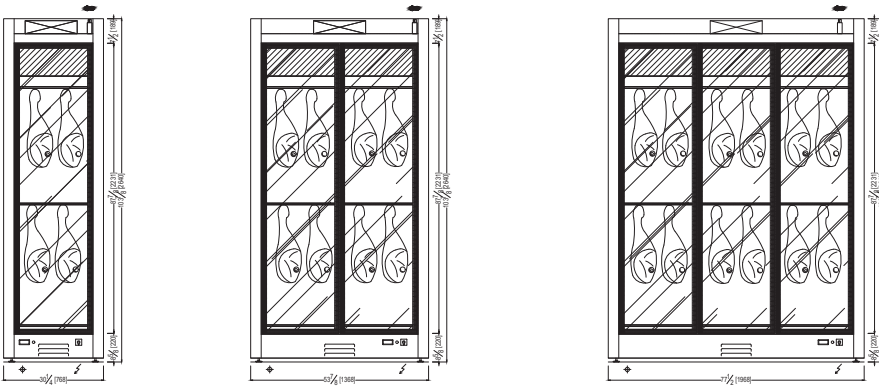

WALL CUT OUT ELEVATIONS

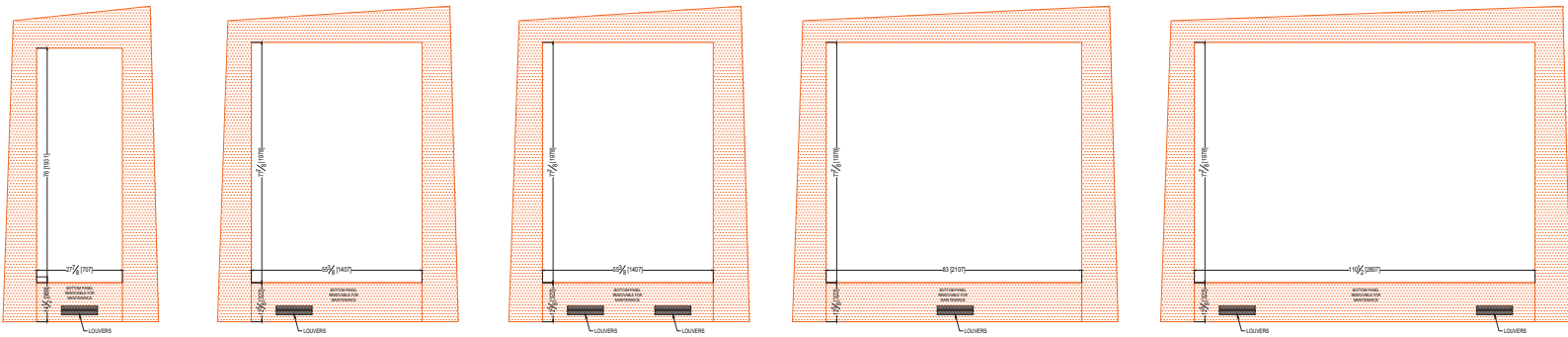

*Oscartek® reserves the right to change, modify, discontinue, or change any features, sizes, or capacity on any model without prior notice.

OSCARTEK®
512 South Airport Blvd., South San Francisco, CA 94080
Tel: 855.885.2400 | 650.342.2400 | Fax: 650.342.7400
sales@oscartek.com | www.oscartek.com



MODELS: GALA CC700, CC1400, CC1400-2T, CC2100, CC2100-2T, CC2800

BACK WINDOW MODELS: GALA CC770BW, CC1370BW, CC1970BW

PASS THROUGH MODELS: GALA CC770PT, CC1370PT, CC1970PT

GALA CHEESE & CHARCUTERIE - STANDARD DEPTH SECTION VIEWS

**STANDARD:
REMOTE**

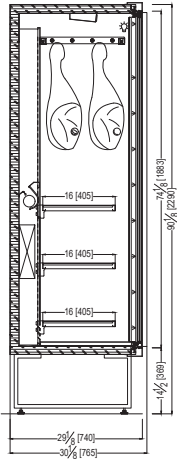

**STANDARD:
SELF-CONTAINED
WITH
GLASS SIDE**

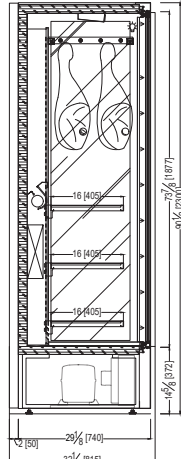

**OPTIONAL:
TOP MOUNTED
CONDENSING
UNIT**

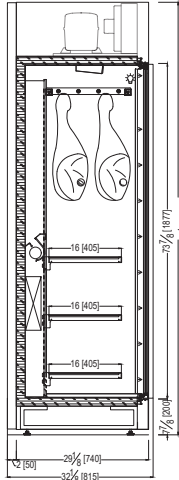

**OPTIONAL:
WOODEN
EXTERIOR
UNIT**

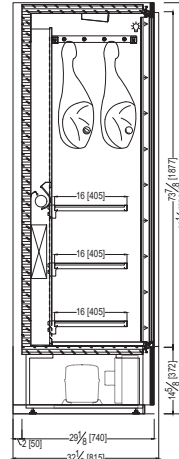

NARROW DEPTH SECTION VIEWS

**STANDARD:
REMOTE**

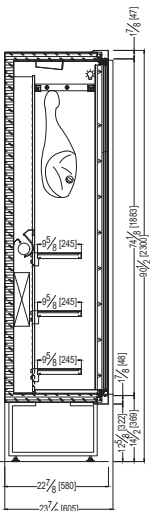

**STANDARD:
SELF-CONTAINED**

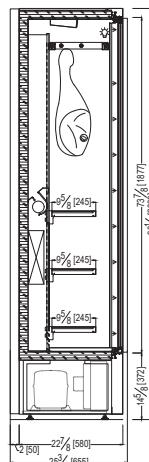

**OPTIONAL:
TOP MOUNTED
CONDENSING
UNIT**

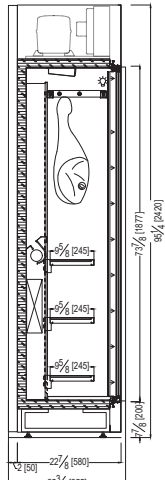

*Oscartek® reserves the right to change, modify, discontinue, or change any features, sizes, or capacity on any model without prior notice.

MODELS: GALA CC700, CC1400, CC1400-2T, CC2100, CC2100-2T, CC2800

BACK WINDOW MODELS: GALA CC770BW, CC1370BW, CC1970BW

PASS THROUGH MODELS: GALA CC770PT, CC1370PT, CC1970PT

GALA CHEESE & CHARCUTERIE - BACK WINDOW & PASS THROUGH
SECTION VIEWS

STANDARD:
BACK WINDOW REMOTE

OPTIONAL:
TOP MOUNTED
CONDENSING UNIT

STANDARD:
PASS THROUGH
REMOTE

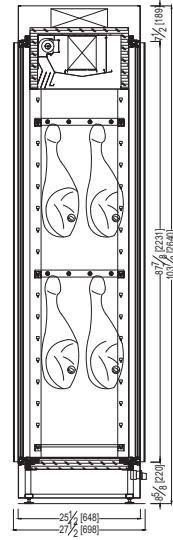
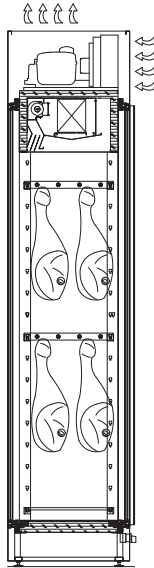
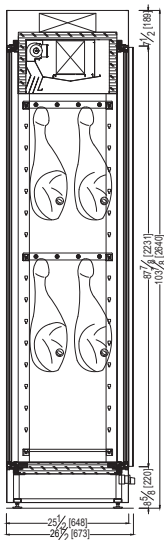

*Oscartek® reserves the right to change, modify, discontinue, or change any features, sizes, or capacity on any model without prior notice.

OSCARTEK®
512 South Airport Blvd., South San Francisco, CA 94080
Tel: 855.885.2400 | 650.342.2400 | Fax: 650.342.7400
sales@oscartek.com | www.oscartek.com





Discover the Art of Display...

Project Name: _____

Item #: _____ Quantity: _____

MODELS: GALA CC700, CC1400, CC1400-2T, CC2100, CC2100-2T, CC2800

GALA CHEESE & CHARCUTERIE - REMOTE							
TECHNICAL FEATURES		MODELS					
Model Name (Model ETL Code)		GALA CC700 (MUROGALA1P)	GALA CC1400 (MUROGALA2P)	GALA CC1400-2T (MUROGALA1P) X2	GALA CC2100 (MUROGALA3P)	GALA CC2100-2T (MUROGALA2P) (MUROGALA1P)	GALA CC2800 (MUROGALA4P)
External Dimensions (L-D-H) Inches-MM	Inches MM	*30 1/4" - 30 1/8" - 90 1/2" *780 - 765 - 2300	*58 1/4" - 30 1/8" - 90 1/2" *1480 - 765 - 2300	*58 1/4" - 30 1/8" - 90 1/2" *1480 - 765 - 2300	*85 7/8" - 30 1/8" - 90 1/2" *2180 - 765 - 2300	*85 7/8" - 30 1/8" - 90 1/2" *2180 - 765 - 2300	*113 3/8" - 30 1/8" - 90 1/2" *2880 - 765 - 2300
Crated Dimensions (L-D-H) Inches-MM	Inches MM	38" - 37" - 102" 960 - 920 - 2570	66" - 37" - 102" 1660 - 920 - 2570	66" - 37" - 102" 1660 - 920 - 2570	93" - 37" - 102" 2360 - 920 - 2570	93" - 37" - 102" 2360 - 920 - 2570	121" - 37" - 102" 3060 - 920 - 2570
Refrigeration	Type	Fan - Ventilated	Fan - Ventilated	Fan - Ventilated	Fan - Ventilated	Fan - Ventilated	Fan - Ventilated
Refrigeration Display Area	Type	Deck	Deck	Deck	Deck	Deck	Deck
Number of Glass Doors	#	1	2	2	3	3	4
Operating Temperature	°F	32°F to 41°F	32°F to 41°F	32°F to 41°F	32°F to 41°F	32°F to 41°F	32°F to 41°F
Condensing Units	#	1	2	2	3	4	5
Compressor	Nr./Type	1 / Hermetic	1 / Hermetic	1 / Hermetic	1 / Hermetic	2 / Hermetic	3 / Hermetic
BTU'S @ +14°F Evap Temperature	BTU/H	2870	5260	(2) 2750	7160	2750 5150	8400
Electric Supply	(V/Ph/Hz)	220/1/60	220/1/60	(2) 220/1/60	220/1/60	(2) 220/1/60	220/1/60
Power Consumption	(W/A)	620/3.5	1200/6.5	(2) 580/3.1	1800/9.6	580/3.1 1150/6.0	2300/12.5
Defrost	Mode/Type	Automatic	Automatic	Automatic	Automatic	Automatic	Automatic
Climatic Class	°F/%RH	75°F-55%RH	75°F-55%RH	75°F-55%RH	75°F-55%RH	75°F-55%RH	75°F-55%RH
Refrigerant Gas (remote/self-contained)	Type	R452a	R452a	R452a	R452a	R452a	R452a
Pipe Size (Suction-Liquid)	(INCHES)	15/32" - 15/64"	35/64" - 5/16"	(2) 15/32" - 15/64"	5/8" - 5/16"	15/32" - 15/64" 35/64" - 5/16"	45/64" - 25/64"
Net Weights	Lb	353	617	705	816	882	970
Crated Weights	Lb	403	677	765	876	942	1030

*DIMENSIONS WITH POLISHED S/S SIDES

GALA CHEESE & CHARCUTERIE - SELF CONTAINED							
TECHNICAL FEATURES		MODELS					
Model Name (Model ETL Code)		GALA CC700 (MUROGALA1P)	GALA CC1400 (MUROGALA2P)	GALA CC1400-2T (MUROGALA1P) X2	GALA CC2100 (MUROGALA3P)	GALA CC2100-2T (MUROGALA2P) (MUROGALA1P)	GALA CC2800 (MUROGALA4P)
External Dimensions (L-D-H) Inches-MM	Inches MM	*30 3/4" - 32 1/8" - 90 1/2" *780 - 815 - 2300	*58 1/4" - 32 1/8" - 90 1/2" *1480 - 815 - 2300	*58 1/4" - 32 1/8" - 90 1/2" *1480 - 815 - 2300	*85 7/8" - 32 1/8" - 90 1/2" *2180 - 815 - 2300	*85 7/8" - 32 1/8" - 90 1/2" *2180 - 815 - 2300	*113 3/8" - 32 1/8" - 90 1/2" *2880 - 815 - 2300
Crated Dimensions (L-D-H) Inches-MM	Inches MM	38" - 37" - 102" 960 - 920 - 2570	66" - 37" - 102" 1660 - 920 - 2570	66" - 37" - 102" 1660 - 920 - 2570	93" - 37" - 102" 2360 - 920 - 2570	93" - 37" - 102" 2360 - 920 - 2570	121" - 37" - 102" 3060 - 920 - 2570
Refrigeration	Type	Fan - Ventilated	Fan - Ventilated	Fan - Ventilated	Fan - Ventilated	Fan - Ventilated	Fan - Ventilated
Refrigeration Display Area	Type	Deck	Deck	Deck	Deck	Deck	Deck
Number of Glass Doors	#	1	2	2	3	3	4
Operating Temperature	°F	32°F to 41°F	32°F to 41°F	32°F to 41°F	32°F to 41°F	32°F to 41°F	32°F to 41°F
Condensing Units	#	1	2	2	3	4	5
Compressor	Nr./Type	1 / Hermetic	1 / Hermetic	1 / Hermetic	1 / Hermetic	2 / Hermetic	3 / Hermetic
BTU'S @ +14°F Evap Temperature	BTU/H	2870	5260	(2) 2750	7160	2750 5150	8400
Electric Supply	(V/Ph/Hz)	220/1/60	220/1/60	(2) 220/1/60	220/1/60	(2) 220/1/60	220/1/60
Power Consumption	(W/A)	620/3.5	1200/6.5	(2) 580/3.1	1800/9.6	580/3.1 1150/6.0	2300/12.5
Defrost	Mode/Type	Automatic	Automatic	Automatic	Automatic	Automatic	Automatic
Climatic Class	°F/%RH	75°F-55%RH	75°F-55%RH	75°F-55%RH	75°F-55%RH	75°F-55%RH	75°F-55%RH
Refrigerant Gas	Type	R290	R290	R290	R290	R290	R290
Pipe Size (Suction-Liquid)	(INCHES)	15/32" - 15/64"	35/64" - 5/16"	(2) 15/32" - 15/64"	5/8" - 5/16"	15/32" - 15/64" 35/64" - 5/16"	45/64" - 25/64"
Net Weights	Lb	353	617	705	816	882	970
Crated Weights	Lb	403	677	765	876	942	1030

*DIMENSIONS WITH POLISHED S/S SIDES

*Oscartek® reserves the right to change, modify, discontinue, or change any features, sizes, or capacity on any model without prior notice.

OSCARTEK®
512 South Airport Blvd., South San Francisco, CA 94080
Tel: 855.885.2400 | 650.342.2400 | Fax: 650.342.7400
sales@oscartek.com | www.oscartek.com





Discover the Art of Display...

Project Name: _____

Item #: _____ Quantity: _____

BACK WINDOW MODELS: GALA CC770BW, CC1370BW, CC1970BW

GALA CHEESE & CHARCUTERIE BACK WINDOW - REMOTE				
TECHNICAL FEATURES		MODELS		
Model Name (Model ETL Code)		GALA BW CC770 (MUROGALA1P)	GALA BW CC1370 (MUROGALA2P)	GALA BW CC1970 (MUROGALA3P)
External Dimensions (L-D-H)	Inches	*30 1/4" - 26 1/2" - 103 7/8"	*53 7/8" - 26 1/2" - 103 7/8"	*77 1/2" - 26 1/2" - 103 7/8"
Inches-MM	MM	*768 - 673 - 2640	*1368 - 673 - 2640	*1968 - 673 - 2640
Crated Dimensions (L-D-H)	Inches	38" - 33" - 115"	61" - 33" - 115"	85" - 33" - 115"
Inches-MM	MM	948 - 828 - 2910	1548 - 828 - 2910	2148 - 828 - 2910
Refrigeration	Type	Fan - Ventilated	Fan - Ventilated	Fan - Ventilated
Refrigeration Display Area	Type	Deck	Deck	Deck
Number of Glass Doors	#	1	2	3
Operating Temperature	°F	32°F to 41°F	32°F to 41°F	32°F to 41°F
Condensing Units	#	1	2	3
Compressor	Nr./Type	1 / Hermetic	1 / Hermetic	1 / Hermetic
BTU'S @ +14°F Evap Temperature	BTU/H	3400	5300	7680
Electric Supply	(V/Ph/Hz)	220/1/60	220/1/60	220/1/60
Power Consumption	(W/A)	1600/8.2	1800/9.8	2200/11.8
Defrost	Mode/Type	Automatic	Automatic	Automatic
Climatic Class	°F/%RH	75°F-55%RH	75°F-55%RH	75°F-55%RH
Refrigerant Gas	Type	R452a	R452a	R452a
Pipe Size (Suction-Liquid)	(INCHES)	15/32"- 15/64"	35/64" - 5/16"	5/8" - 5/16"
Net Weights	Lb	551	794	970
Crated Weights	Lb	611	854	1030

*DIMENSIONS WITH POLISHED S/S SIDES

GALA CHEESE & CHARCUTERIE BACK WINDOW - SELF CONTAINED				
TECHNICAL FEATURES		MODELS		
Model Name (Model ETL Code)		GALA BW CC770 (MUROGALA1P)	GALA BW CC1370 (MUROGALA2P)	GALA BW CC1970 (MUROGALA3P)
External Dimensions (L-D-H)	Inches	*30 1/4" - 26 1/2" - 111 3/4"	*53 7/8" - 26 1/2" - 111 3/4"	*77 1/2" - 26 1/2" - 111 3/4"
Inches-MM	MM	*768 - 673 - 2840	*1368 - 673 - 2840	*1968 - 673 - 2840
Crated Dimensions (L-D-H)	Inches	38" - 33" - 115"	61" - 33" - 115"	85" - 33" - 115"
Inches-MM	MM	948 - 828 - 2910	1548 - 828 - 2910	2148 - 828 - 2910
Refrigeration	Type	Fan - Ventilated	Fan - Ventilated	Fan - Ventilated
Refrigeration Display Area	Type	Deck	Deck	Deck
Number of Glass Doors	#	1	2	3
Operating Temperature	°F	32°F to 41°F	32°F to 41°F	32°F to 41°F
Condensing Units	#	1	2	3
Compressor	Nr./Type	1 / Hermetic	1 / Hermetic	1 / Hermetic
BTU'S @ +14°F Evap Temperature	BTU/H	3400	5300	7680
Electric Supply	(V/Ph/Hz)	220/1/60	220/1/60	220/1/60
Power Consumption	(W/A)	1600/8.2	1800/9.8	2200/11.8
Defrost	Mode/Type	Automatic	Automatic	Automatic
Climatic Class	°F/%RH	75°F-55%RH	75°F-55%RH	75°F-55%RH
Refrigerant Gas	Type	R455/R454c	R455/R454c	R455/R454c
Pipe Size (Suction-Liquid)	(INCHES)	15/32"- 15/64"	35/64" - 5/16"	5/8" - 5/16"
Net Weights	Lb	551	794	970
Crated Weights	Lb	611	854	1030

*DIMENSIONS WITH POLISHED S/S SIDES

*Oscartek® reserves the right to change, modify, discontinue, or change any features, sizes, or capacity on any model without prior notice.

OSCARTEK®

512 South Airport Blvd., South San Francisco, CA 94080

Tel: 855.885.2400 | 650.342.2400 | Fax: 650.342.7400

sales@oscartek.com | www.oscartek.com





Discover the Art of Display...

Project Name: _____

Item #: _____ Quantity: _____

PASS THROUGH MODELS: GALA CC770PT, CC1370PT, CC1970PT

GALA CHEESE & CHARCUTERIE PASS THROUGH - REMOTE				
TECHNICAL FEATURES		MODELS		
Model Name (Model ETL Code)		GALA PT CC770 (MUROGALA1P)	GALA PT CC1370 (MUROGALA2P)	GALA PT CC1970 (MUROGALA3P)
External Dimensions (L-D-H)	Inches	*30 1/4" - 26 1/2" - 103 7/8"	*53 7/8" - 26 1/2" - 103 7/8"	*77 1/2" - 26 1/2" - 103 7/8"
Inches-MM	MM	*768 - 673 - 2640	*1368 - 673 - 2640	*1968 - 673 - 2640
Crated Dimensions (L-D-H)	Inches	38" - 33" - 115"	61" - 33" - 115"	85" - 33" - 115"
Inches-MM	MM	948 - 828 - 2910	1548 - 828 - 2910	2148 - 828 - 2910
Refrigeration	Type	Fan - Ventilated	Fan - Ventilated	Fan - Ventilated
Refrigeration Display Area	Type	Deck	Deck	Deck
Number of Glass Doors	#	1	2	3
Operating Temperature	°F	32°F to 41°F	32°F to 41°F	32°F to 41°F
Condensing Units	#	1	2	3
Compressor	Nr./Type	1 / Hermetic	1 / Hermetic	1 / Hermetic
BTU'S @ +14°F Evap Temperature	BTU/H	3400	5300	7680
Electric Supply	(V/Ph/Hz)	220/1/60	220/1/60	220/1/60
Power Consumption	(W/A)	1600/8.2	1800/9.8	2200/11.8
Defrost	Mode/Type	Automatic	Automatic	Automatic
Climatic Class	°F/%RH	75°F-55%RH	75°F-55%RH	75°F-55%RH
Refrigerant Gas	Type	R452a	R452a	R452a
Pipe Size (Suction-Liquid)	(INCHES)	15/32" - 15/64"	35/64" - 5/16"	5/8" - 5/16"
Net Weights	Lb	573	838	1036
Crated Weights	Lb	633	898	1096

*DIMENSIONS WITH POLISHED S/S SIDES

GALA CHEESE & CHARCUTERIE PASS THROUGH - SELF CONTAINED				
TECHNICAL FEATURES		MODELS		
Model Name (Model ETL Code)		GALA PT CC770 (MUROGALA1P)	GALA PT CC1370 (MUROGALA2P)	GALA PT CC1970 (MUROGALA3P)
External Dimensions (L-D-H)	Inches	*30 1/4" - 26 1/2" - 111 3/4"	*53 7/8" - 26 1/2" - 111 3/4"	*77 1/2" - 26 1/2" - 111 3/4"
Inches-MM	MM	*768 - 673 - 2840	*1368 - 673 - 2840	*1968 - 673 - 2840
Crated Dimensions (L-D-H)	Inches	38" - 33" - 115"	61" - 33" - 115"	85" - 33" - 115"
Inches-MM	MM	948 - 828 - 2910	1548 - 828 - 2910	2148 - 828 - 2910
Refrigeration	Type	Fan - Ventilated	Fan - Ventilated	Fan - Ventilated
Refrigeration Display Area	Type	Deck	Deck	Deck
Number of Glass Doors	#	1	2	3
Operating Temperature	°F	32°F to 41°F	32°F to 41°F	32°F to 41°F
Condensing Units	#	1	2	3
Compressor	Nr./Type	1 / Hermetic	1 / Hermetic	1 / Hermetic
BTU'S @ +14°F Evap Temperature	BTU/H	3400	5300	7680
Electric Supply	(V/Ph/Hz)	220/1/60	220/1/60	220/1/60
Power Consumption	(W/A)	1600/8.2	1800/9.8	2200/11.8
Defrost	Mode/Type	Automatic	Automatic	Automatic
Climatic Class	°F/%RH	75°F-55%RH	75°F-55%RH	75°F-55%RH
Refrigerant Gas	Type	R455/R454c	R455/R454c	R455/R454c
Pipe Size (Suction-Liquid)	(INCHES)	15/32" - 15/64"	35/64" - 5/16"	5/8" - 5/16"
Net Weights	Lb	573	838	1036
Crated Weights	Lb	633	898	1096

*DIMENSIONS WITH POLISHED S/S SIDES

*Oscartek® reserves the right to change, modify, discontinue, or change any features, sizes, or capacity on any model without prior notice.

OSCARTEK®
512 South Airport Blvd., South San Francisco, CA 94080
Tel: 855.885.2400 | 650.342.2400 | Fax: 650.342.7400
sales@oscartek.com | www.oscartek.com

