



Project _____
 AIA # _____ SIS # _____
 Item # _____ Quantity _____ C.S.I. Section 114000

UHT SERIES

Compact Undercounter with Drawers
 Refrigerator Models/Self-Contained



STANDARD PRODUCT FEATURES

- Stainless Steel Exterior Top, Sides & Drawers
- Front Breathing Self-Contained Refrigeration System
- Environmentally Friendly, Low GWP R-290 Refrigerant
- Automatic Non-Electric Condensate Evaporator
- Electronic Control
- Full-Length Drawer Handle with Gasket Guard
- Magnetic Snap-In EZ-Clean Drawer Gasket(s)
- Self-Closing Stainless Steel Drawers with Stay-Open Feature
- Heavy Gauge Stainless Steel Drawer with Slide
- 8' (2.4 m) NEMA Cord & Plug Attached
- Set of Six (6) 4" High Casters

ACCESSORIES & OPTIONS (*field installed)

- CK21 (six 6" (15.2 cm) high casters for 60" models)
- CK25 (six 3½" (8.9 cm) high casters for 60" models)
- CK27 (six 2¾" (6.9 cm) high casters for 60" models)
- LK6 (six 6" (15.24 cm) high legs for 60" models)
- Optional accessory kits shipped separately for field installatio

FACTORY INSTALLED OPTIONS

Stainless Steel Finished Back (model numbers will have '-SB' suffix)



This unit is listed to the applicable ETL and NSF Standards by an approved NRTL. Consult the factory or unit's data plate for approval information.

AVAILABLE CONFIGURATIONS

60" Wide Model

<u>Model</u>	<u>Style</u>
UHT60-DD	Four Drawer Refrigerator

Approved by _____ Date _____ Approved by _____ Date _____

MODEL:
UHT60-DD

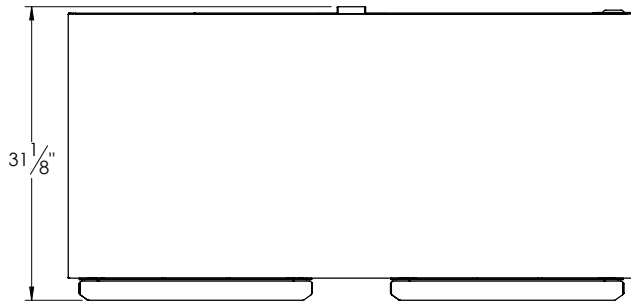

TOP VIEW

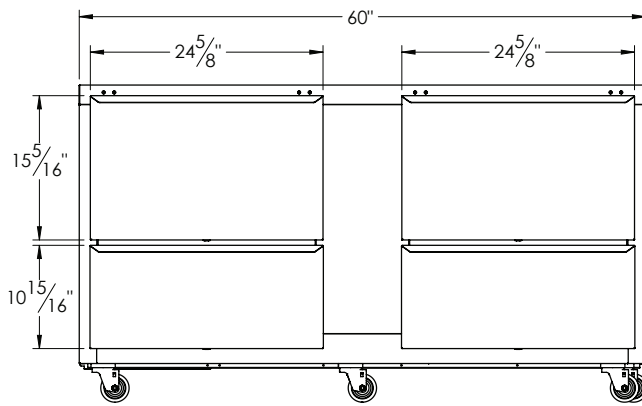
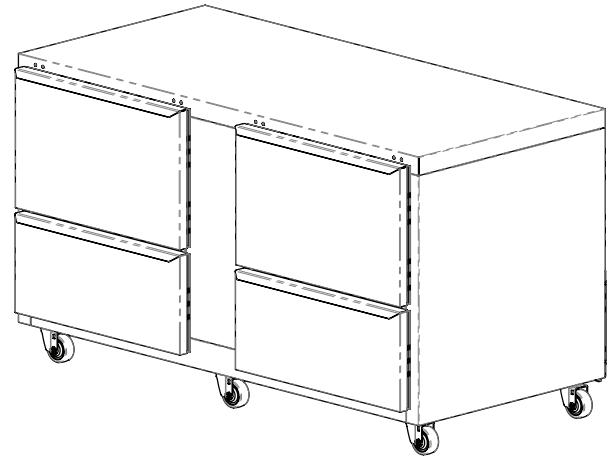

ELEVATION

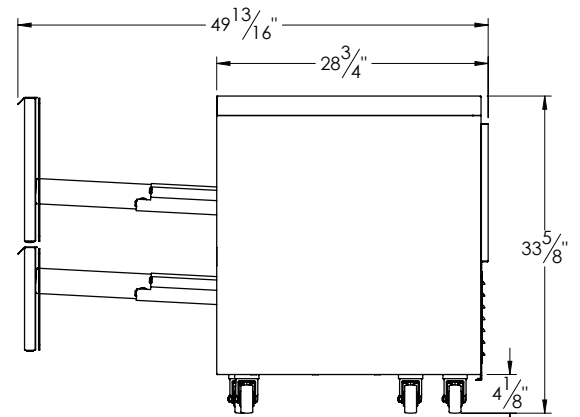

SIDE VIEW



UHT SERIES

Compact Undercounter with Drawers
Refrigerator Models/Self-Contained

MODEL:

UHT60-DD

EQUIPMENT SPECIFICATIONS

MODEL	UHT60-DD
DIMENSIONAL DATA	
Net Capacity cu. ft.	16.7 (473 l)
# of 1/6 size pans per drawer	8
# of drawers per cabinet	4
# of 1/6 size pans per cabinet	32
Length - overall in.	60 (152.4 cm)
Depth - overall in.	31 ¹ / ₈ (79 cm)
Depth - drawer open in.	49 ¹³ / ₁₆ (126.5 cm)
Width drawer in.	29 ⁵ / ₈ (75.2 cm)
Height - overall on 4" casters	33 ⁵ / ₈ (85.4 cm)
ELECTRICAL DATA (NEMA 5-15P attached)	
Voltage	115/60/1
Full Load Amps KWH/24HR ¹	7.2 1.1
REFRIGERATION DATA	
Refrigerant	R-290
Refrigerant Amount oz.	5 (142 g)
BTU/HR ² H.P.	1680 1/5 HP
SHIPPING DATA	
Length - crated in.	69 (175 cm)
Width - crated in.	42 (107 cm)
Height - crated in.	41 (104 cm)
Volume - crated cu. ft.	91 (2577 l)
Weight - crated lbs.	344 (156 kg)

NOTES:

1. KWH/24HR = Kilowatt usage per 24 hours
2. Based on a 90°F ambient and 20°F evaporator.

CONSTRUCTION, HARDWARE, INSULATION

Cabinet exterior front, one piece sides, and drawers are constructed of heavy gauge stainless steel. The cabinet is insulated with an average of 2" thick high density, non-CFC, foamed in place polyurethane.

REFRIGERATION SYSTEM

A balanced, rear mounted, front breathing, self-contained refrigeration system using environmentally friendly R-290 refrigerant is provided. It features a capillary tube, air cooled hermetic compressor, a forced air evaporator coil and a non-electric condensate evaporator. An 8' (2.4m) NEMA cord and plug is provided. Standard operating temperature for refrigerator is 34° to 38°F (1.1° to 3.3°C).

CONTROLLER

An electronic digital control is supplied standard. It includes a 3-Digit LED display, and a Fahrenheit or Celsius temperature scale display capability.

DRAWERS

They are constructed using heavy gauge stainless steel drawer slides and 1 5/16" diameter stainless steel rollers. Gasket profile and material simplify cleaning and increase overall gasket life. Drawers include both a self-closing and stay-open feature.

DOMESTIC WARRANTY

Both a six year parts and labor warranty and a seven year compressor warranty (self-contained models only) are provided standard.

When ordering please specify: Voltage, Hinging, and Options.

Equipped with one NEMA 5-15P Plug



CONTINUED PRODUCT DEVELOPMENT MAY NECESSITATE SPECIFICATION CHANGES WITHOUT NOTICE.