



Project \_\_\_\_\_  
 AIA # \_\_\_\_\_ SIS # \_\_\_\_\_  
 Item # \_\_\_\_\_ Quantity \_\_\_\_\_ C.S.I. Section 114000



## CLCS66eN-EGR STEAM

### High Temperature Corner Scrapper Rack Conveyor Dishwashing Machine

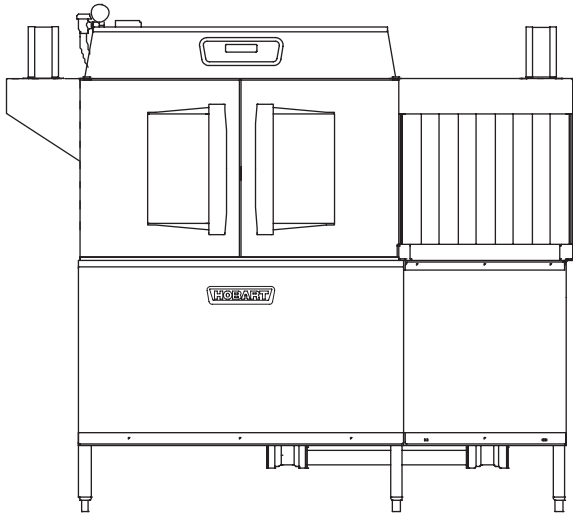

#### STANDARD FEATURES

- + 202 racks per hour
- + 22" power scrapper
- + Drain water energy recovery (DWER)
- + Opti-Rinse™ system
- + Drain water tempering kit
- + Rapid return conveyor drive mechanism
- + Internal stainless steel pressure-less 30 KW booster heater
- + Large double door opening for ease of cleaning
- + Doors are insulated & hinged with door interlock switches
- + 19.5" chamber height opening (accepts sheet pans)
- + Top mounted micro-processor control module
- + Energy saver mode (programmable auto-shut down)
- + Dirty water indicator
- + Manager activated low temperature alert
- + NSF rated configurable pot and pan dwell mode
- + Configurable "intelligent" delime notification
- + Service diagnostics
- + Self-aligning wash manifolds
- + Stainless steel anti-clogging wash arms
- + Removable pump intake screen
- + Stainless steel self-draining pump and impeller
- + Single, sloping scrap screen and deep scrap basket
- + Stainless panels enclose perimeter and bottom
- + Door actuated drain closure
- + Vent fan control
- + Booster heater control

#### OPTIONS & ACCESSORIES (Available at extra cost)

- Standard, short, and extended stainless steel vent hoods
- Direct drive unloader – adds 38" length. Reference spec F39520 for more details
- Side loader – SL23 adds 23" length, SL30 adds 30" length. Reference specs F40926 and F40927 for more details
- Blower-dryer – adds 33 3/8" to length. Reference spec F40252 for more details (**ships separate from dishmachine, contact Hobart Service for installation**)
- Flanged feet kit (requires two kits)
- Higher than standard chamber (24" opening)
- Table limit switch with 10' wire
- Correctional package (contact Hobart for details)
- Pressure regulator valve (PRV), for use with external booster
- Water shock absorber kit
- Factory-mounted circuit breakers (contact Hobart for details)
- Common electrical connection (see page 4)

#### SPECIFIER STATEMENT

Specified dishwasher will be Hobart CLCS66eN Energy Recovery steam tank heat model with corner scrapper, drain water energy recovery (DWER) and Opti-Rinse™. Includes 22" power scrapper, insulated ergonomic cabinet style doors, dirty water indicator, configurable "intelligent" de-lime notification, top mounted computer controls, and NSF approved pot and pan cycle mode. The wash tank utilizes durable precision pressure sensor monitors in lieu of conventional mechanical floats.

CLEAN SERIES – CLCS66eN-EGR STEAM

Approved by \_\_\_\_\_ Date \_\_\_\_\_ Approved by \_\_\_\_\_ Date \_\_\_\_\_



# CLCS66eN-EGR STEAM

## High Temperature Corner Scrapper Rack Conveyor Dishwashing Machine

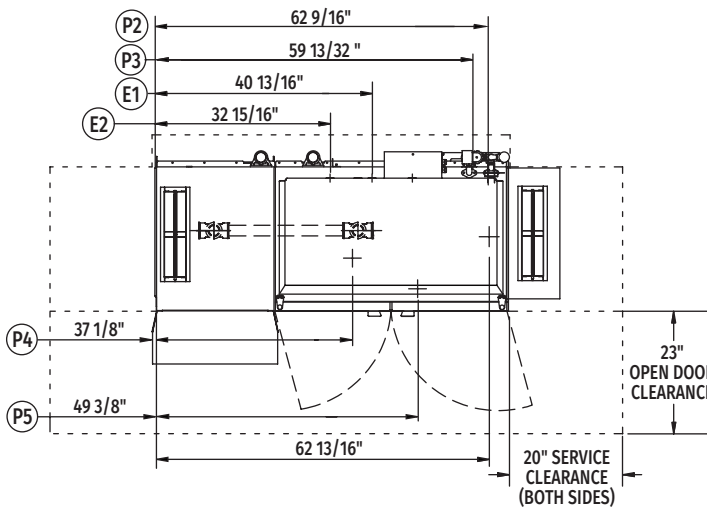

Top View Left to Right

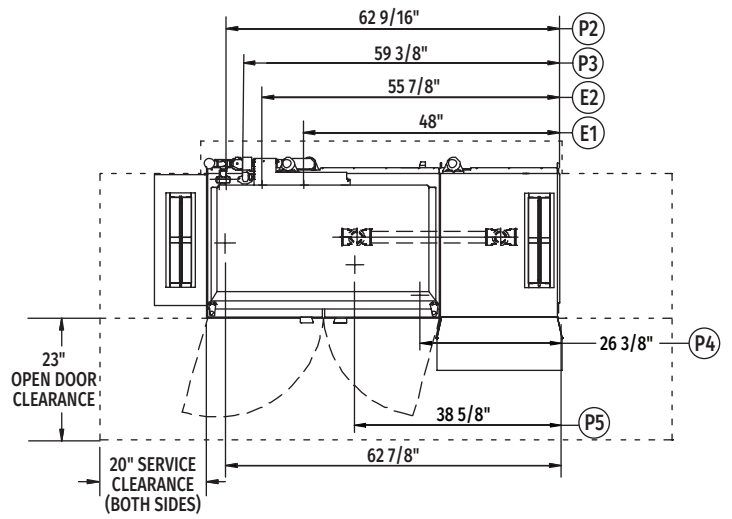

Top View Right to Left

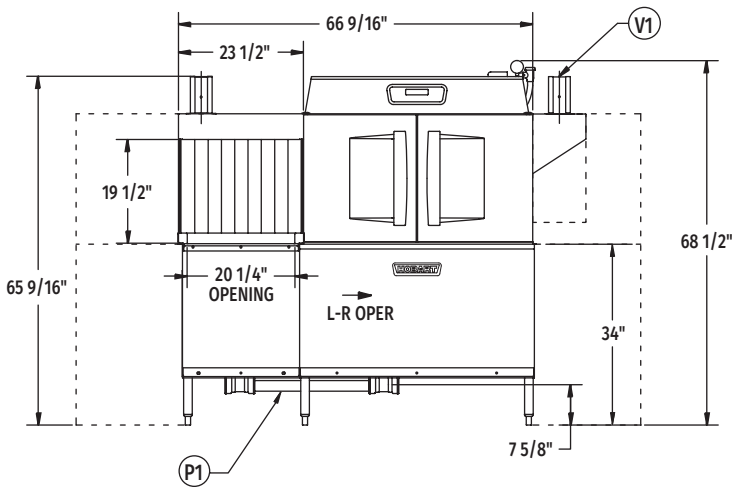

Front View Left to Right

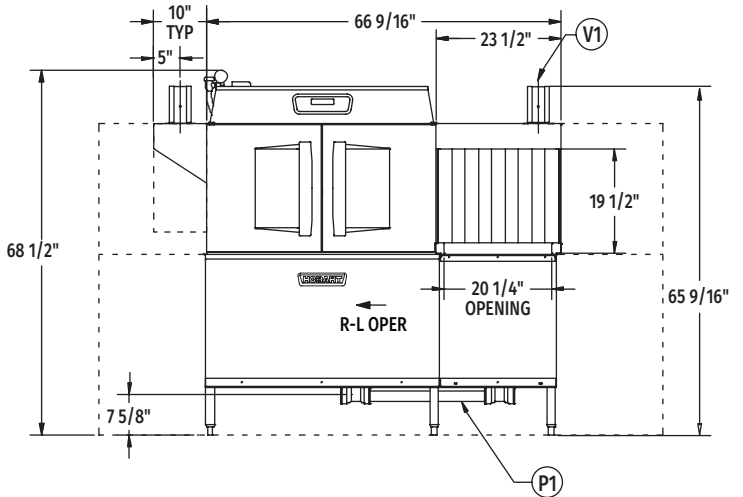

Front View Right to Left

### VENT HOOD OPTIONS

(Adjustable, vent stack can be adjusted 1" to either side)

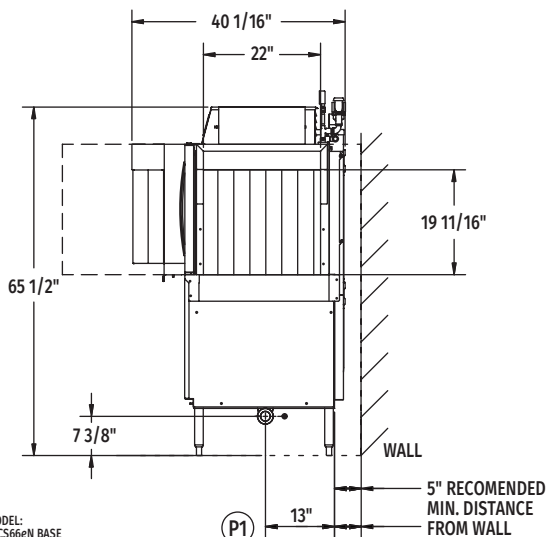
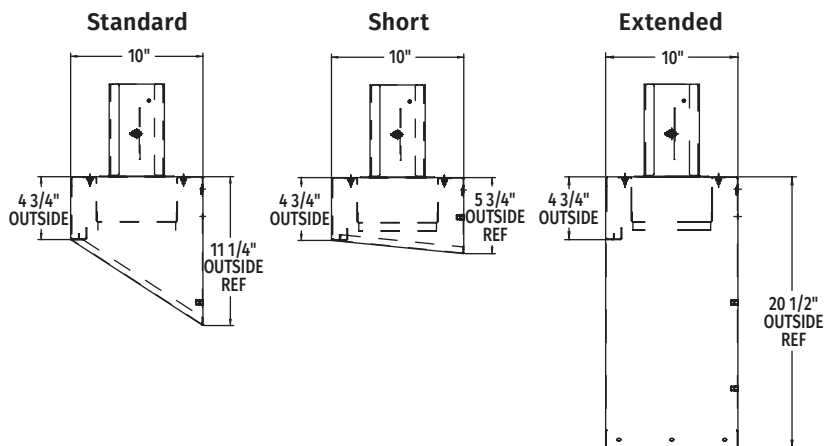

Side View

Reference page 4  
for installation drawings

MODEL:  
CLCS66eN BASE  
L-R OPERATION  
D-974813  
REV B

MODEL:  
CLCS66eN BASE  
R-L OPERATION  
D-974812  
REV B



# CLCS66eN-EGR STEAM High Temperature Corner Scrapper Rack Conveyor Dishwashing Machine

## LEGEND

Electrical Connections	
<b>E1</b>	Motors and controls 1-1/4" or 2" conduit, 63-3/4" AFF.
<b>E2</b>	Internal electric booster (in lieu of external steam booster) 1-1/4" or 2" conduit, 63-3/4" AFF.
<b>NOTE:</b> Common electrical connection (single point) available, see page 4 for details. Booster information, see page 4.	
Plumbing Connections	
<b>P1</b>	Drain. May be drained to either side of valve, plug opposite side 2" FPT. Recommend a floor drain minimum of 12" from machine for access and maintenance. 7-3/8" AFF.
<b>P2</b>	Hot water. 1/2" FPT connection. 1/2", 11-3/16" AFF. See plumbing notes for required temperatures.
<b>P3</b>	Cold water connection 1/2" FPT, cold water temperature 80°F, maximum 7-3/8" AFF.
Steam Connections (P4 or P5)	
<b>P4</b>	Steam coils: 10 to 50 PSI flowing, 3/4" FPT, 11-18" AFF.
<b>P5</b>	Condensate return: A 10 PSI minimum differential pressure across the steam trap must be maintained. 3/4" FPT, 11-1/8" AFF one connection. (One bucket type trap furnished).
Vent Connections	
<b>V1</b>	Optional vent hoods, 4" x 16" vent stack with damper.

<b>E1</b>	Electrical Connection (3 PH only) Motors and Controls		
Voltage	Rated Amps	Minimum Supply Circuit Ampacity	Maximum Protective Device
208/60/3	16.6	20	20
240/60/3	16.6	20	20
480/60/3	9.4	15	15

Dishmachine not provided with internal GFCI protection.

**NOTE:** Additional CLeN Voltages and Amperages are available, see document F40972.

CLPS66eN-EGR Steam Heat Dissipation	
BTU/HR.	
Latent	Sensible
46,200	19,800

## SPECIFICATIONS

### Capacities

Racks per Hour (NSF rated) . . . . .	202
Wash Tank (U.S. gallons) . . . . .	23
Power Scrapper (U.S. gallons) . . . . .	23
Conveyor Speed (feet per minute) . . . . .	5.6

### Motor Horsepower

Drive . . . . .	1/6
Wash . . . . .	.2
Power Scrapper . . . . .	.2

### Water Consumption

U.S. Gallons per Hour (maximum use at 20 PSI) . . . . .	126
U.S. Gallons per Rack . . . . .	0.62
Peak Drain Flow (U.S. gallons per minute) . . . . .	38

### Heating

Tank Heat, steam coils (pounds per hour) . . . . .	65
Electric Booster (built-in) (kW for 70°F rise) . . . . .	30
Steam Booster (external) (pounds per hour) . . . . .	60
(If used on 20 PSI steam, 20 PSI water flowing, 130°F entering water raised to 180°F minimum)	

### Venting

Load End (minimum CFM) . . . . .	200
Unload End (minimum CFM) . . . . .	400

Shipping Weight (approximate) . . . . .895 lbs.

Crated Dimensions . . . . .76"L x 38"W x 78"H

<b>E2</b>	Booster Heat 30 kW Minimum 110°F Incoming Water		
Voltage	Rated Amps	Minimum Supply Circuit Ampacity	Maximum Protective Device
208/60/3	83.9	90	90
240/60/3	80.2	90	90
480/60/3	40.1	50	50

**WARNING:** Plumbing and electrical connections should be made by qualified personnel who will observe all the applicable plumbing, sanitary, safety codes and National Electrical Code.

**Plumbing Notes:** Minimum incoming water temperatures: 110°F for 30kW internal booster. Building flowing water pressure to dish machine is 20 PSI (+/- 5 PSI).

Single cold water connection supplies both drain water energy recovery and drain water tempering.

Recommended water hardness to be 3 grains or less for best results.

**Steam Heat Only:** Flowing steam pressures above 50 PSI must have a pressure regulator (by others) installed in the steam line.

Shut off valve must be supplied (by others) in the steam line to the dish machine.



# CLCS66eN-EGR STEAM High Temperature Corner Scrapper Rack Conveyor Dishwashing Machine

## COMMON ELECTRICAL CONNECTION (SINGLE POINT) – CONTACT FACTORY FOR ADDITIONAL INFORMATION

Common Electrical Connection (Includes Motors & Controls and Electric Booster Heater)			
Voltage	MACHINE AND 30KW BOOSTER		
	Rated Amps	Minimum Supply Circuit Ampacity	Maximum Protective Device
208/60/3	100.2	110	110
240/60/3	100.2	110	110
480/60/3	49.5	70	70

**NOTE:** Additional CLeN Voltages and Amperages are available, see document F40972.

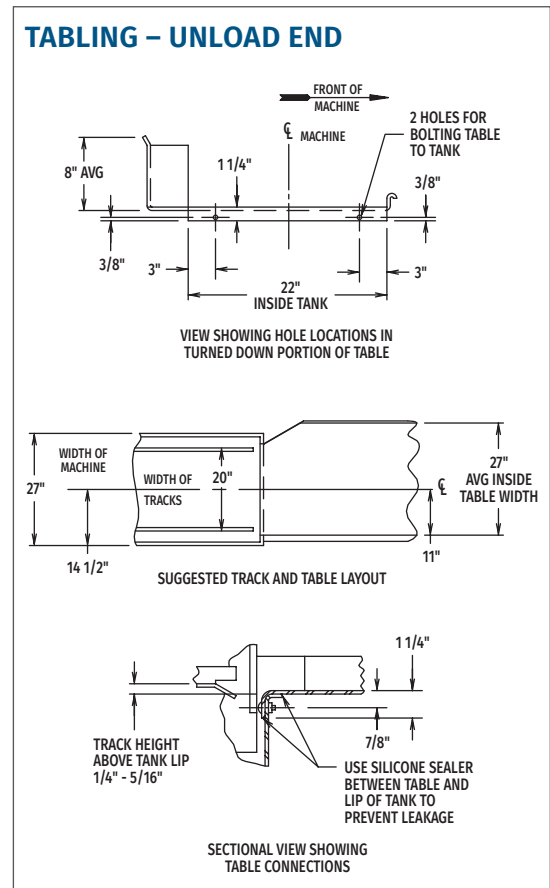
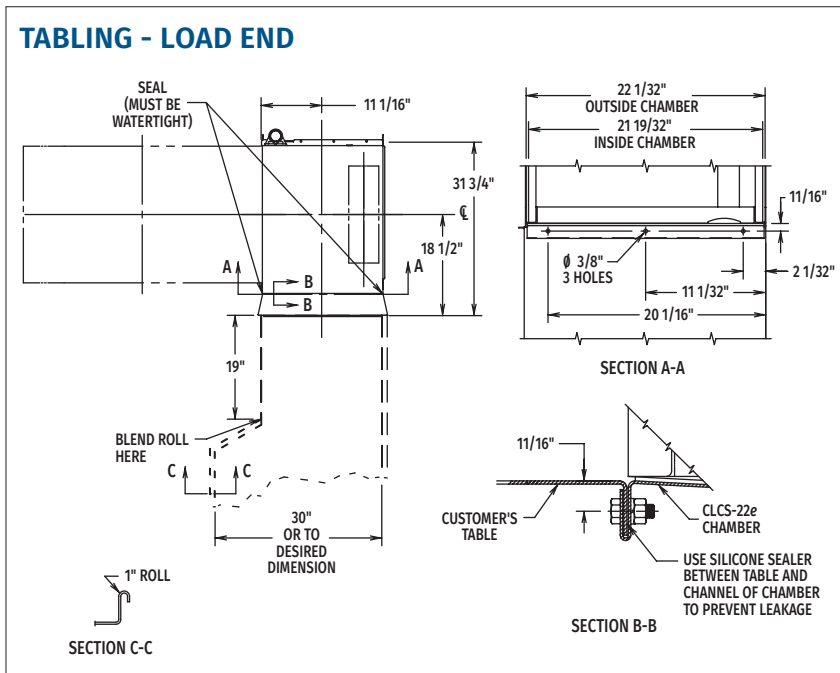

As continued product improvement is a policy of Hobart, specifications are subject to change without notice.