

VALUE LINE TRAY DELIVER CARTS – SINGLE DOOR WITH TWO TRAYS PER SLIDE

Compliant with
NSF/ANSI Standard 2



DXPTVL2T1D10

*Shown with optional
3-sided top rail*

Item Numbers

DXPTVL2T1D10
DXPTVL2T1D12
DXPTVL2T1D14
DXPTVL2T1D16
DXPTVL2T1D18
DXPTVL2T1D20

Application

TVL Economy Carts offer you a cart that is built ready to have all of its options added as needed. It's the quick and easy answer to a "ready-made" tray service cart.

This equipment is intended for "Industrial Use Only".

Options

- All options are available for field installation only.
- The use of simple hand tools are all that is required to install the field options. "No Drilling of Holes are Required"

Construction

The Value Line cart single door tray delivery cart with an all stainless steel modular construction. Comes with standard perimeter bumper frame and standard drop down latch for doors for transport. The cart has (standard) 5" tray height spacing with 2 trays per shelf for a total of a 10, 12, 14, 16, 18, & 20 capacities for the cart. The cart comes with adjustable tray slides that can be adjust per slot (1.6875" height changes per slot). The cart is built ready with hole locations to add top rail assembly or you can remove the back panel and add a second door to change it to a pass-thru cart. All carts come standard with bottom mounted floor drain and 5" Performa casters with sealed stainless steel bearings (2 rigid, 2 swivel with side lock brakes).

Standard Features

- Full wrap around bumper
- 5" Performa casters
- Drop style transport door latch
- 5" tray spacing
- Drain included on all models

Compatible Tray Sizes

- 14" x 18"
- 15" x 20"
- 12" x 19"
- 12" x 20"

Warranty

One year parts and labor.

**We do not accept returns on any Dinex equipment or Dinex custom products.
Please contact your local Dinex rep to ensure order accuracy prior to ordering.**

DINEX®

4711 E. Hefner Road
Oklahoma City, OK 73131
800.654.8210 | 405.475.5600
www.dinex.com

VALUE LINE TRAY DELIVER CARTS – SINGLE DOOR WITH TWO TRAYS PER SLIDE

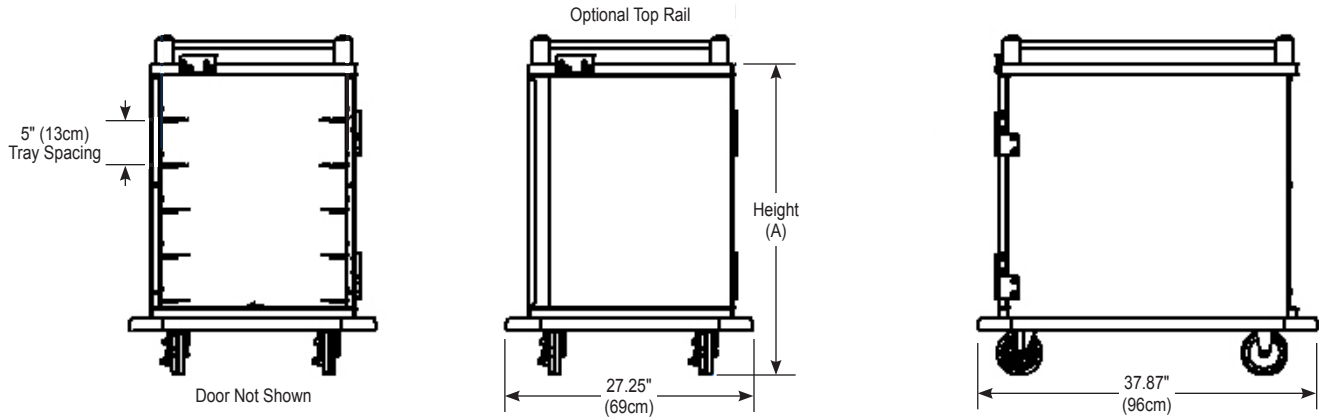

Items and Dimensions

ITEM NUMBER	WIDTH	DEPTH	HEIGHT (A)	TRAY CAPACITY	SHIP WEIGHT	SHIP CUBE
DXPTVL2T1D10	27.25" (69cm)	37.87" (96cm)	34.6" (88cm)	10	165 lb (75kg)	48.0
DXPTVL2T1D12	27.25" (69cm)	37.87" (96cm)	39.6" (101cm)	12	177 lb (80kg)	54.0
DXPTVL2T1D14	27.25" (69cm)	37.87" (96cm)	44.7" (114cm)	14	189 lb (86kg)	60.0
DXPTVL2T1D16	27.25" (69cm)	37.87" (96cm)	49.7" (126cm)	16	201 lb (91kg)	66.0
DXPTVL2T1D18	27.25" (69cm)	37.87" (96cm)	54.7" (139cm)	18	213 lb (97kg)	72.0
DXPTVL2T1D20	27.25" (69cm)	38.12" (97cm)	59.8" (152cm)	20	225 lb (102kg)	78.0

All carts are designed for the following tray sizes:

14" x 18", 15" x 20", 12" x 19", 12" x 20"

Standard Options Available:

- 3-Sided Top Rails
- Rear Door Kits for Pass Thru Applications

Please confirm that you have the most current specification sheet by visiting www.dinex.com.

It is Dinex's policy to offer equipment which is design certified by companies that have been accredited at the federal level by the Occupational Safety and Health Agency (OSHA) and ANSI as a national recognized testing laboratory. These companies include CSA International, Underwriters Laboratories, Edison Testing Laboratories and National Sanitation Foundation. However, a continuing program of product improvement makes it necessary to submit new models to the agencies as they are developed. Consequently, all models may not bear the appropriate labels at all times.

Dinex reserves the right to change specifications and product design without notice. Such revisions do not entitle the buyer to corresponding changes, improvements, additions or replacements for previously purchased equipment.



DINEX®

4711 E. Hefner Road
Oklahoma City, OK 73131
800.654.8210 | 405.475.5600
www.dinex.com