



Your Solutions Partner

Installation and Operation Manual

BGA Adjustable Food Guard Series

BGA2-74-SS-GF-LHL-UL
Shown with recessed
HotFrost Unit

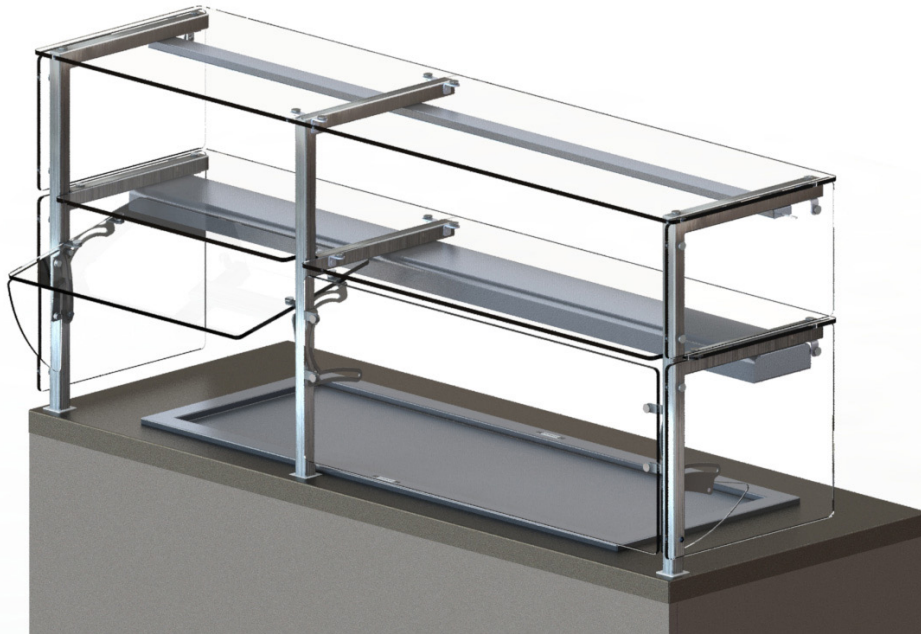

BGA2-74-SS-GF-OS2-UL
Shown with Recessed Hot-
Frost Drop in
and HotFrost Overshelf

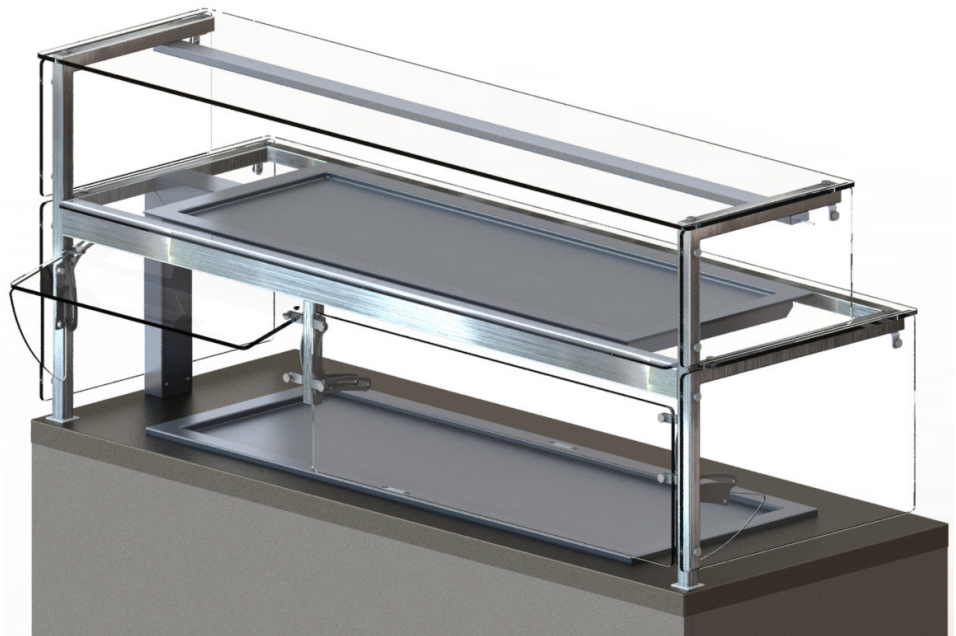

CAUTION: Please read this manual completely before attempting to install, operate or service this equipment



WARNING For CA residents: go to www.dukemfg.com/prop65 for prop 65 warning

This manual is Copyright © 2023 Duke Manufacturing Co. All rights reserved. Reproduction without written permission is prohibited. Duke is a registered trademark of the Duke Manufacturing Co.

P/N 229413
REV B 12/22/2023

TABLE OF CONTENTS

Important Safety Instructions..... 2-4

Pre Installation..... 5

BGA Food Guard Specifications6-15

Touchscreen Control Specifications 16

Wire Diagram 16 - 17

Installing Mechanical Control 18

Operation of Mechanical Control 19

Front Glass Operation 19

Through Mount Instructions.....20

Flush Mount Instructions21

Chase Cutout and Details.....21

Glass Installation.....22

Led and /or Heater Installation Instructions.....23

Maintenance24

IMPORTANT SAFETY INSTRUCTIONS

Throughout this manual, you will find the following safety words and symbols that signify important safety risks with regards to operating or maintaining the equipment.



Indicates a hazardous situation which, if not avoided, could result in death or serious injury.



Indicates a hazardous situation which, if not avoided, could result in minor or moderate injury.



Indicates Important Information



Indicates electrical shock hazard which, if not avoided, could result in death or serious injury and/or equipment damage.



Indicates hot surface which, if not avoided, could result in minor or moderate injury.



Electrical shock hazard. Do not wash with water jet or hose.

In addition to the warnings and cautions in this manual, use the following guidelines for safe operation of the unit.

- Read all instructions before using equipment.
- For your safety, the equipment is furnished with a properly grounded cord connector. Do not attempt to remove or disconnect the grounded connector.
- Install or locate the equipment only for its intended use as described in this manual.
- Do not use corrosive chemicals on this equipment.
- Do not operate this equipment if it has a damaged cord or plug, if it is not working properly, or if it has been damaged or dropped.
- This equipment should be serviced by qualified personnel only. Contact the nearest Duke authorized service facility for adjustment or repair.
- Do not block or cover any openings on the unit.
- Do not immerse cord or plug in water.
- Keep cord away from heated surfaces.
- Do not allow cord to hang over edge of table or counter.

The following warnings and cautions appear throughout this manual and should be carefully observed.

- Turn the unit off, disconnect the power source and allow unit to cool down before performing any service or maintenance on the unit.
- The procedures in this manual may include the use of chemical products. You must read the Material Safety Data Sheets before using any of these products.
- The unit should be grounded according to local electrical codes to prevent the possibility of electrical shock. It requires a grounded receptacle with dedicated electrical lines, protected by fuses or circuit breaker of the proper rating, in accordance with all applicable regulations.
- Disposal of the unit must be in accordance with local environmental codes and/or any other applicable codes.
- This appliance is not intended for use by persons (including children) with reduced physical, sensory or mental capabilities, or lack of experience and knowledge, unless they have been given supervision or instruction concerning use of the appliance by a person responsible for their safety.
- Do not store explosive substances such as aerosol cans with a flammable propellant in this appliance.



**ELECTRICAL SHOCK HAZARD UNIT MUST BE SAFETY GROUNDED, EARTHED.
DO NOT MODIFY, DEFEAT ELECTRICAL CONNECTIONS OR ALTER PLUG.**

ELECTRICAL CONNECTIONS

⚠️ WARNING

BEFORE CONNECTING THE UNIT TO THE POWER SOURCE, VERIFY THAT THE VOLTAGE AND PHASE OF THE POWER SOURCE ARE IDENTICAL TO THE VOLTAGE AND PHASE INFORMATION ON THE DATA LABEL.

⚠️ WARNING

ALL MAINS DISCONNECT MUST BE INCORPORATED IN THE FIXED WIRING IN ACCORDANCE WITH LOCAL WIRING RULES

EARTHING INSTRUCTIONS

1. THE UNIT MUST BE GROUNDED. Grounding reduces risk of electric shock by providing an escape wire for the electric current if an electrical short occurs. This unit is equipped with a cord having a grounding wire with a grounding plug. The plug must be plugged into a receptacle that is properly installed and grounded.
2. Consult a qualified electrician or service agent if grounding instructions are not completely understood, or if doubt exists as to whether the unit is properly grounded.
3. DO NOT USE AN EXTENSION CORD. If the product power cord is too short, have a qualified electrician install a three-slot receptacle (or the country specific receptacle for International Units). This unit should be plugged into a dedicated circuit with the electrical rating as provided on the product data plate.

EXTERNAL EQUIPOTENTIAL BONDING TERMINAL (EXPORT ONLY)

1. This equipment has supplemental bonding terminal. The terminal provides an external bonding connection used in addition to the earthing prong on the plug. The terminal provides a connection for bonding to the equipment enclosure. The external equipotential bonding terminal located on the rear outside surface of the unit, the terminal is marked with the symbol to the right.



INSTALLATION CODES AND STANDARDS

In the United States, the Unit must be installed in accordance with the following:

1. State and local codes.
2. National Electrical Code (ANSI/NFPA No. 70, latest edition) available from the National Fire Protection Association, Batterymarch Park, Quincy, MA 02269.
3. Vapor Removal from Cooking Equipment, (NFPA-96, latest edition) available from NFPA.
4. Sealed to the counter upon which the equipment is placed per NSF/ANSI 4 standard.

In Canada, the Unit must be installed in accordance with the following:

1. Local codes.
2. Canadian Electrical Code (CSA C22.2 No. 3, latest edition) available from the Canadian Standards Association, 5060 Spectrum Way, Mississauga, Ontario, Canada L4W 5N6.

“For CE Units, the Unit must be installed in accordance with the following:

1. Local codes.
2. European (IEC/CENELEC) Electrical Code

PRE-INSTALLATION

Receiving and Inspection **UNPACKING UNIT**

Inspect the shipping carton and/or container, carefully noting any exterior damage on the delivery receipt; also note any damage not evident on the outside of the shipping container (concealed damage). Contact the carrier immediately and file a damage claim with them. Save all packing materials when filing a claim. Freight damage claims are the responsibility of the purchaser and are not covered by the warranty.

- Inspect unit for damage such as, broken glass, etc.
- Report any dents or breakage to source of purchase immediately.
- Do not attempt to use unit if damaged.
- Remove all materials from packaging.
- If unit has been stored in extremely cold area, wait a few hours before handling the glass or components.

BGA1 Single Shelf Single Sided

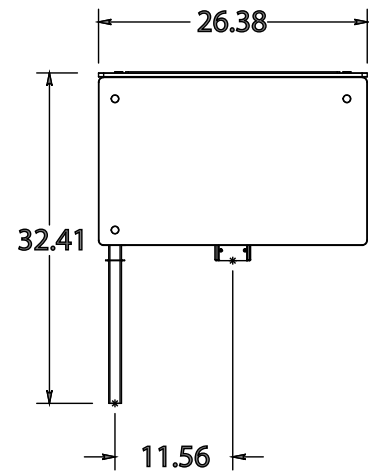
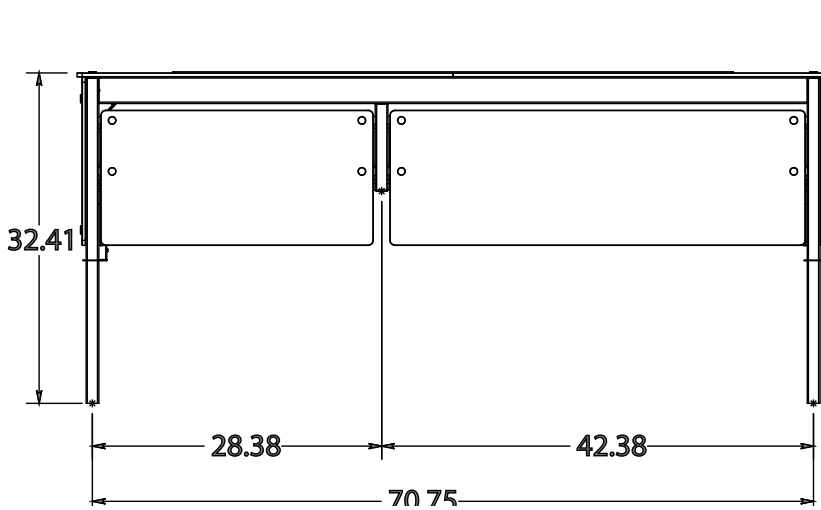
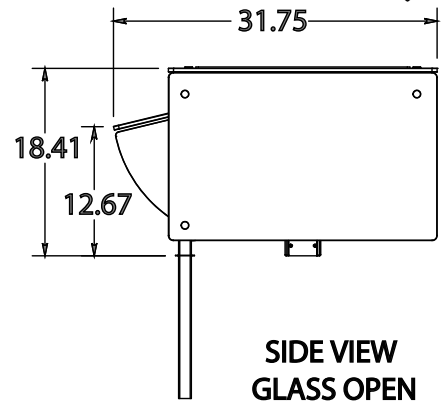
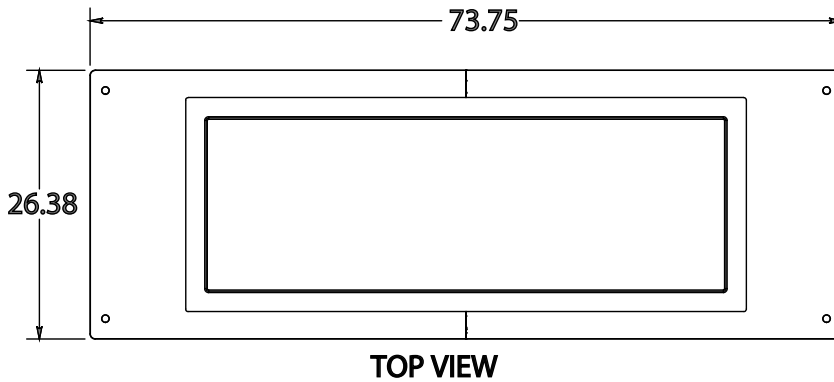
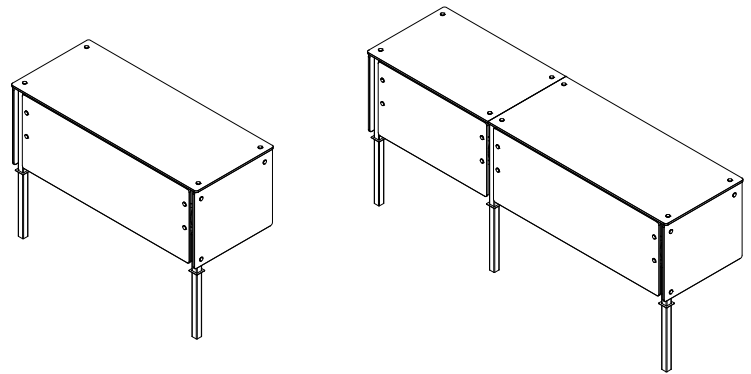

BGA1-74-SS Shown Above

Dimensions:

Freight Class: 100

Overall Height: 32.5 in./82.55 cm			Depth Overall: 19.25 in./48.90 cm						
Model	Length		Section 1 Length		Section 2 - Length		Cube ft. Crated	Crated Ship Weight	
	Overall		CL/CL		CL/CL			lbs.	kg
	in.	cm	in.	cm	in.	cm			
BGA1-32-SS	31.75	80.65	28.75	73.025	N/A		12	72	32.66
BGA1-46-SS	45.75	116.21	42.75	108.59	N/A		17	93	42.18
BGA1-60-SS	59.75	151.77	56.75	144.145	N/A		22	114	51.71
BGA1-74-SS	73.75	187.33	42.375	107.63	28.375	72.07	27	142	64.41
BGA1-88-SS	87.75	222.89	42.375	107.63	42.375	107.63	32	170	77.11

BGA1 = Single Shelf

Electrical Specs for lights located on Page 10

BGA2 Dual Shelf Single Sided

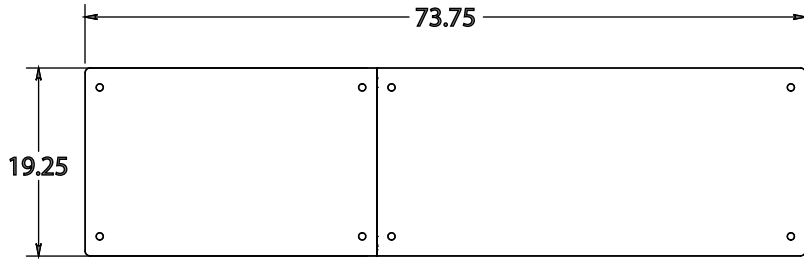
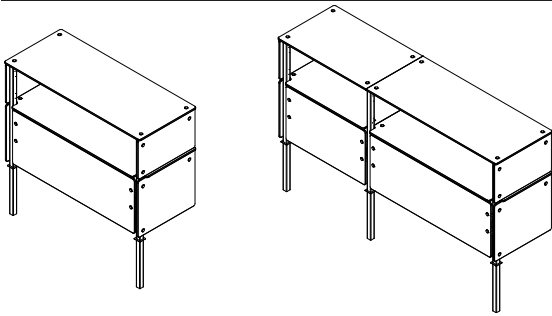

TOP VIEW

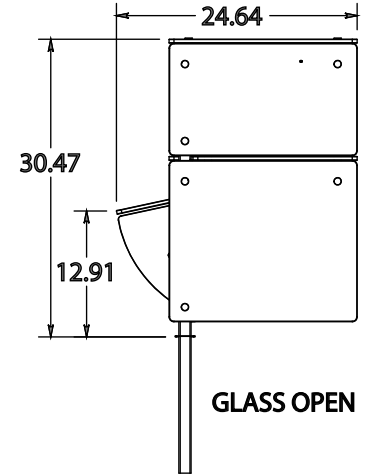

GLASS OPEN

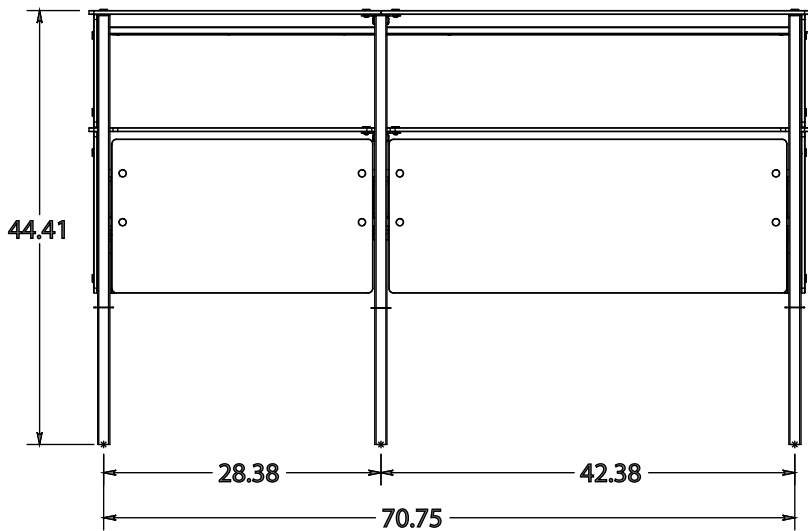

FRONT VIEW

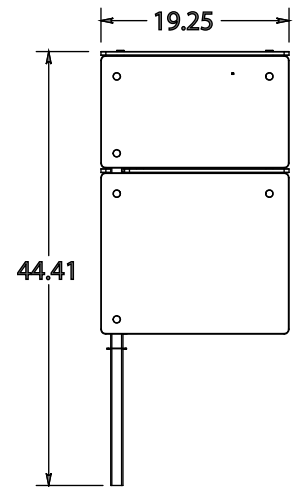

SIDE VIEW

BGA2-74-SS Dual Shelf Shown Above

Dimensions:

Freight Class: 100

Overall Height: 44.5 in./113.03 cm			Depth Overall: 19.25 in./48.90 cm						
Model	Length		Section 1 Length		Section 2 - Length		Cube ft. Crated	Crated Ship Weight	
	Overall		CL/CL		CL/CL			lbs.	kg
	in.	cm	in.	cm	in.	cm			
BGA2-32-SS	31.75	80.65	28.75	73.025	N/A		23	93	42.18
BGA2-46-SS	45.75	116.21	42.75	108.59	N/A		28	114	51.71
BGA2-60-SS	59.75	151.77	56.75	144.145	N/A		40	135	61.23
BGA2-74-SS	73.75	187.33	42.375	107.63	28.375	72.07	50	163	73.94
BGA2-88-SS	87.75	222.89	42.375	107.63	42.375	107.63	65	191	86.64

BGA2 = Dual Shelf

Electrical Specs for lights located on Page 10

BGA1 Single Shelf Double Sided

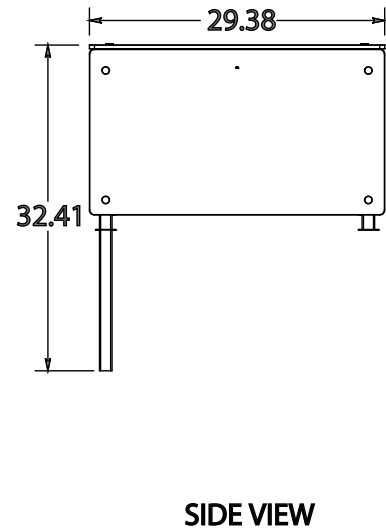
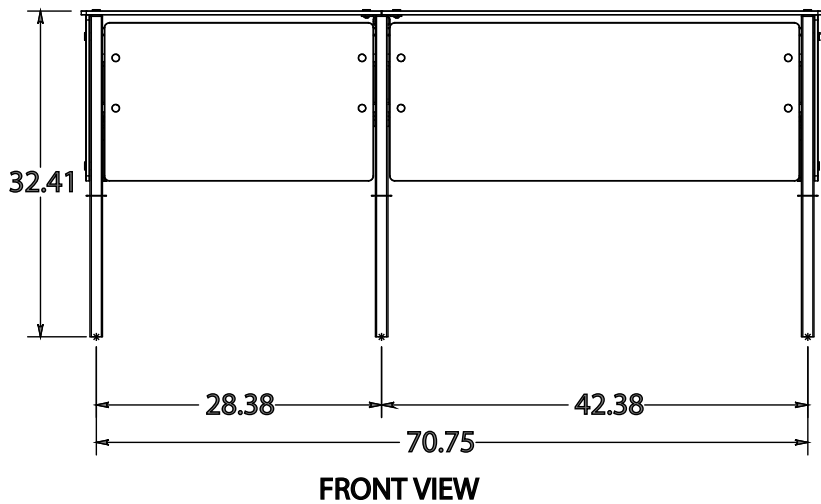
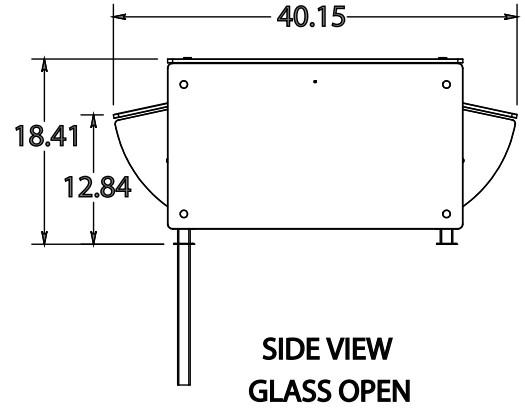
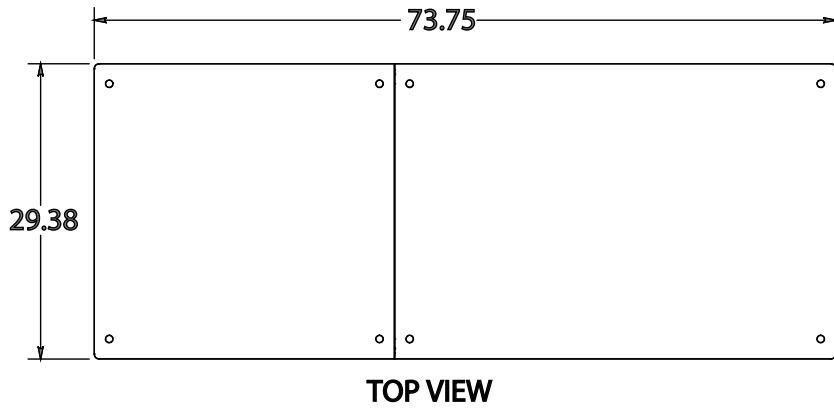
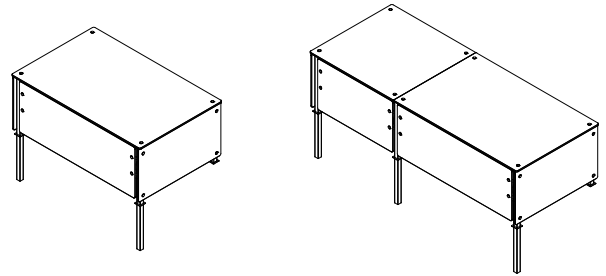

BGA1-74-DS Shown Above

Dimensions:

Freight Class: 100

Model	Length		Section 1 Length		Section 2 - Length		Cube ft. Crated	Crated Ship Weight	
	Overall		CL/CL		CL/CL			lbs.	kg
	in.	cm	in.	cm	in.	cm			
BGA1-32-DS	31.75	80.65	28.75	73.025	N/A		36	86	39.01
BGA1-46-DS	45.75	116.21	42.75	108.59	N/A		42	107	48.53
BGA1-60-DS	59.75	151.77	56.75	144.145	N/A		62	128	58.06
BGA1-74-DS	73.75	187.33	42.375	107.63	28.375	72.07	90	156	70.76
BGA1-88-DS	87.75	222.89	42.375	107.63	42.375	107.63	108	184	83.46

**BGA1 = Single Shelf
DS - Double Sided**

Electrical Specs for lights located on Page 10

BGA2 Dual Shelf Double Sided

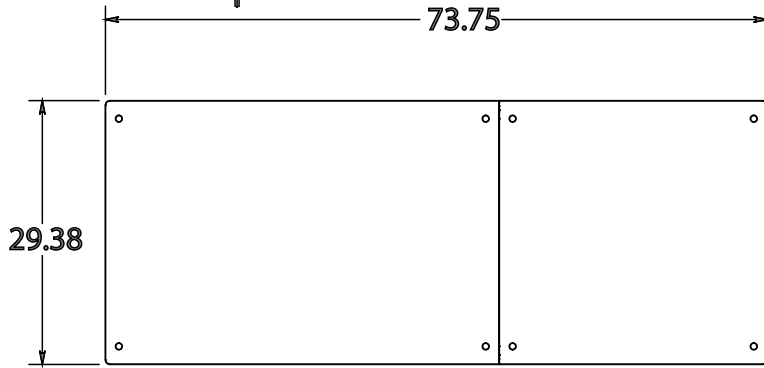
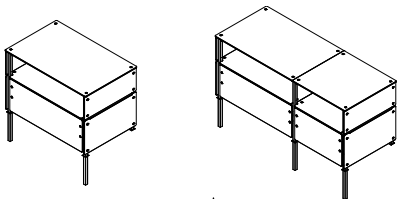

TOP VIEW

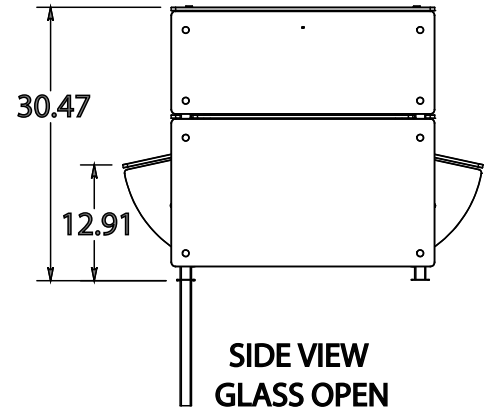

SIDE VIEW
GLASS OPEN

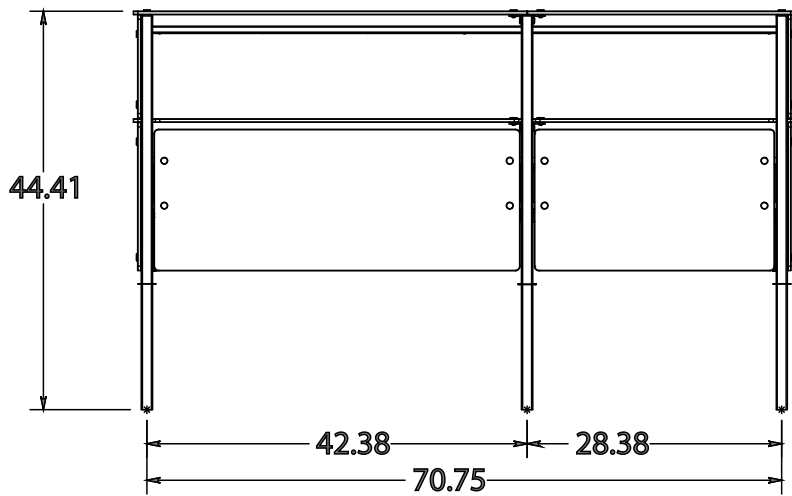

FRONT VIEW

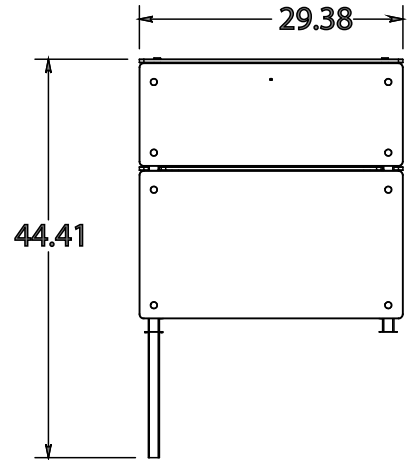

SIDE VIEW

BGA2-74-DS Shown Above

Dimensions:

Freight Class: 100

Overall Height: 44.5 in./113.03 cm			Depth Overall: 29.38 in./74.62 cm						
Model	Length		Section 1 Length		Section 2 - Length		Cube ft. Crated	Crated Ship Weight	
	Overall		CL/CL		CL/CL			lbs.	kg
	in.	cm	in.	cm	in.	cm			
BGA2-32-DS	31.75	80.65	28.75	73.025	N/A		25	107	48.53
BGA2-46-DS	45.75	116.21	42.75	108.59	N/A		35	128	58.06
BGA2-60-DS	59.75	151.77	56.75	144.145	N/A		46	149	67.59
BGA2-74-DS	73.75	187.33	42.375	107.63	28.375	72.07	56	177	80.29
BGA2-88-DS	87.75	222.89	42.375	107.63	42.375	107.63	67	205	92.99

BGA2 = Dual Shelf
DS = Double Sided

Electrical Specs for lights located on Page 10

BGA Food Guard Series

Electrical Specifications:

MODEL	120 Volt						120/208 Volt			120/240 Volt		
	LED Only NEMA 5-15P			LED and Heater			LED and Heater			LED and Heater		
	Watts	Amps	Nema	Watts	Amps	NEMA	Watts	Amps	NEMA	Watts	Amps	NEMA
BGA1-32-SS	6	.05	5-15/P	357	3.0	5-15P	357	1.8	L14-20	357	1.6	L14-20
BGA1-46-SS	9.6	.08	5-15/P	586	4.9	5-15P	586	2.9	L14-20	586	2.5	L14-20
BGA1-60-SS	16.8	.14	5-15/P	941	7.9	5-15P	941	4.6	L14-20	941	4.1	L14-20
BGA1-74-SS	20.4	.17	5-15/P	1180	9.9	5-15P	1180	5.8	L14-20	1180	5.0	L14-20
BGA1-88-SS	24	.20	5-15/P	1296	10.8	5-15P	1296	6.3	L14-20	1296	5.5	L14-20
BGA2-32-SS	12	.10	5-15/P	364	3.1	5-15P	364	1.9	L14-20	364	1.7	L14-20
BGA2-46-SS	19.2	.16	5-15/P	596	5.0	5-15P	596	3.0	L14-20	596	2.6	L14-20
BGA2-60-SS	33.6	.28	5-15/P	957	8.0	5-15P	957	4.7	L14-20	957	4.2	L14-20
BGA2-74-SS	40.8	.34	5-15/P	1200	10.1	5-15P	1200	6.0	L14-20	1200	5.2	L14-20
BGA2-88-SS	48	.40	5-15/P	1317	11.0	5-15P	1317	6.5	L14-20	1317	5.8	L14-20
BGA1-32-DS	6	.05	5-15/P	357	3.0	5-15P	357	1.8	L14-20	357	1.6	L14-20
BGA1-46-DS	9.6	.08	5-15/P	586	4.9	5-15P	586	2.9	L14-20	586	2.5	L14-20
BGA1-60-DS	16.8	.14	5-15/P	941	7.9	5-15P	941	4.6	L14-20	941	4.1	L14-20
BGA1-74-DS	20.4	.17	5-15/P	1180	9.9	5-15P	1180	5.8	L14-20	1180	5.0	L14-20
BGA1-88-DS	24	.20	5-15/P	1296	10.8	5-15P	1296	6.3	L14-20	1296	5.5	L14-20
BGA2-32-DS	12	.10	5-15/P	364	3.1	5-15P	364	1.9	L14-20	364	1.7	L14-20
BGA2-46-DS	19.2	.16	5-15/P	596	5.0	5-15P	596	3.0	L14-20	596	2.6	L14-20
BGA2-60-DS	33.6	.28	5-15/P	957	8.0	5-15P	957	4.7	L14-20	957	4.2	L14-20
BGA2-74-DS	40.8	.34	5-15/P	1200	10.1	5-15P	1200	6.0	L14-20	1200	5.2	L14-20
BGA2-88-DS	48	.40	5-15/P	1317	11.0	5-15P	1317	6.5	L14-20	1317	5.8	L14-20

BGA1 = Single Shelf
BGA2 = Double Shelf
SS - Single Sided
DS = Double Sided

Control Specs

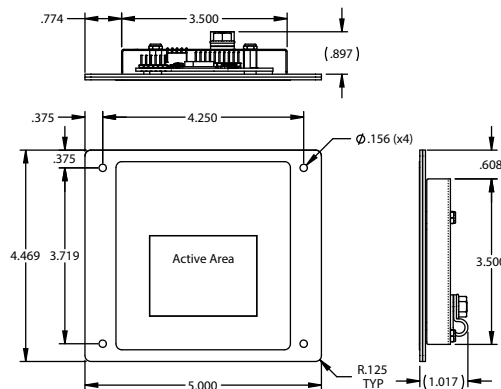

BGA1 Single Shelf Single Sided - Over Shelf

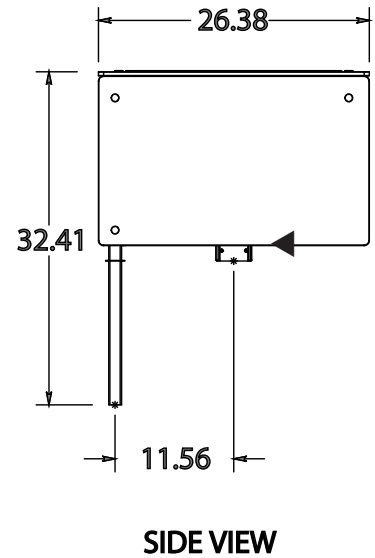
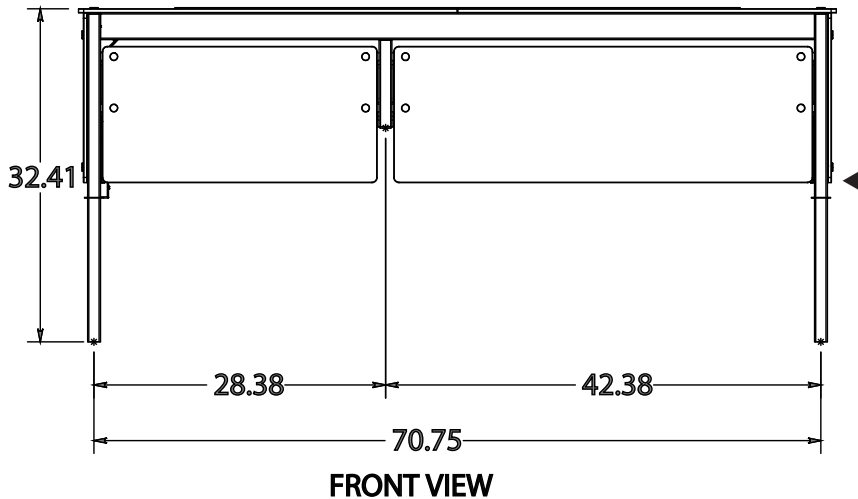
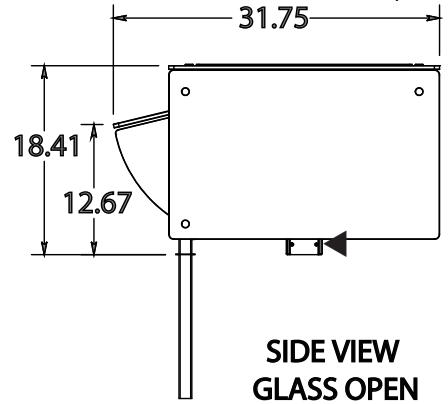
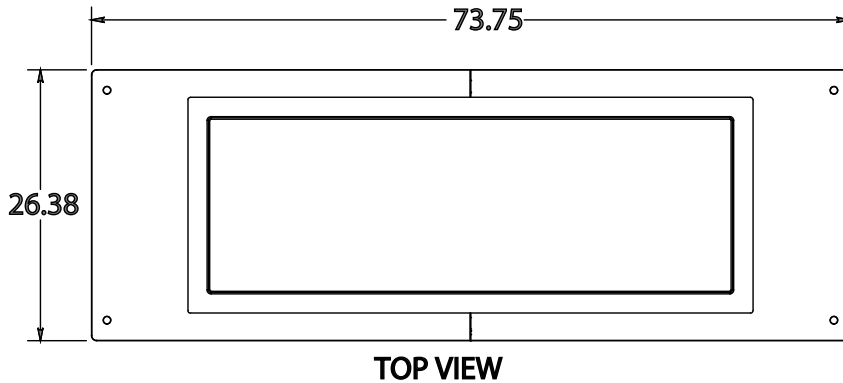
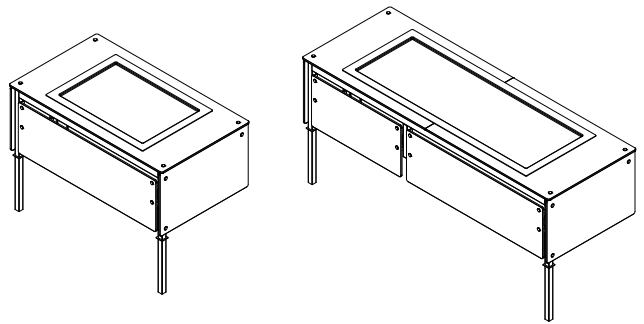

BGA1-74-SS-OS Shown Above

Dimensions:

Freight Class: 100

Model	Length		Section 1 Length		Section 2 - Length		Cube ft. Crated	Crated Ship Weight	
	Overall		CL/CL		CL/CL			lbs.	kg
	in.	cm	in.	cm	in.	cm			
BGA1-46-SS-OS	45.75	116.21	42.75	108.59	N/A		23	93	42.18
BGA1-60-SS-OS	59.75	151.77	56.75	144.145	N/A		30	114	51.71
BGA1-74-SS-OS	73.75	187.33	42.375	107.63	28.375	72.07	37	142	64.41
BGA1-88-SS-OS	87.75	222.89	42.375	107.63	42.375	107.63	44	170	77.11

BGA1 = Single Shelf

◀ Electrical Connection
Electrical Specs for overshelf are located on Page 16

BGA2 Dual Shelf Single Sided - Over Shelf

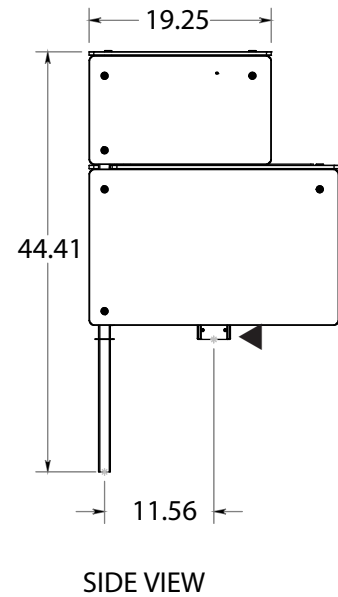
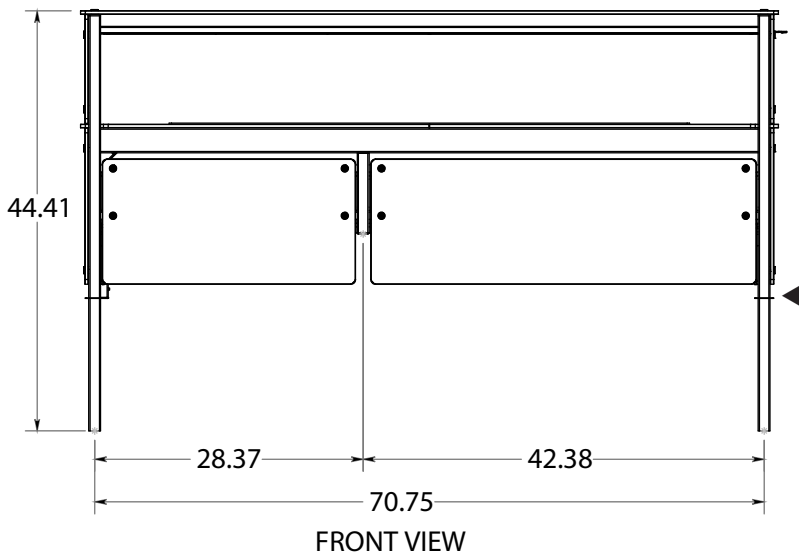
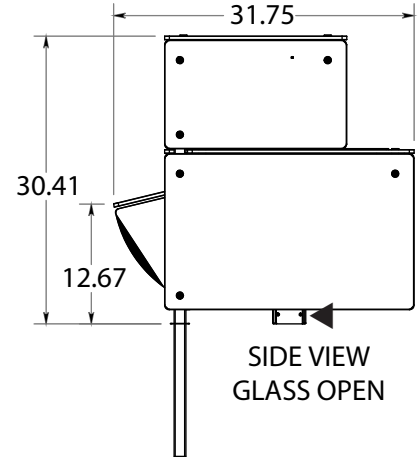
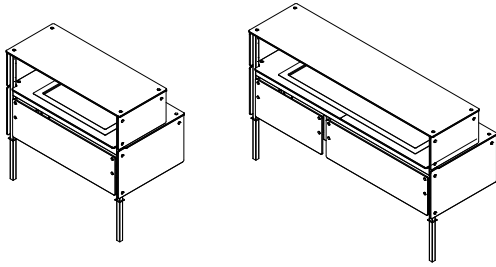

BGA2-74-SS-OS Shown Above

Dimensions:

Freight Class: 100

Model	Overall Height: 44.5 in. /113.03 cm				Depth Overall: 26.38 in./67.00 cm				Electrical Specs		
	Length		Section 1 Length		Section 2 - Length		Cube ft. Crated	Crated Ship Weight		120 Volt Electrical Specs LED Only NEMA 5-15P	
	Overall		CL/CL		CL/CL			lbs.	kg	Watts	Amps
	in.	cm	in.	cm	in.	cm					
BGA2-46-SS-OS	45.75	116.21	42.75	108.59	N/A		32	114	51.71	19.2	0.16
BGA2-60-SS-OS	59.75	151.77	56.75	144.145	N/A		41	135	61.23	33.6	0.28
BGA2-74-SS-OS	73.75	187.33	42.375	107.63	28.375	72.07	51	163	73.94	40.8	0.34
BGA2-88-SS-OS	87.75	222.89	42.375	107.63	42.375	107.63	60	191	86.64	48.0	0.40

BGA2 = Dual Shelf

Electrical Connection

Electrical Specs for overshelf are located on Page 16

BGA1 Single Shelf Double Sided with Over Shelf

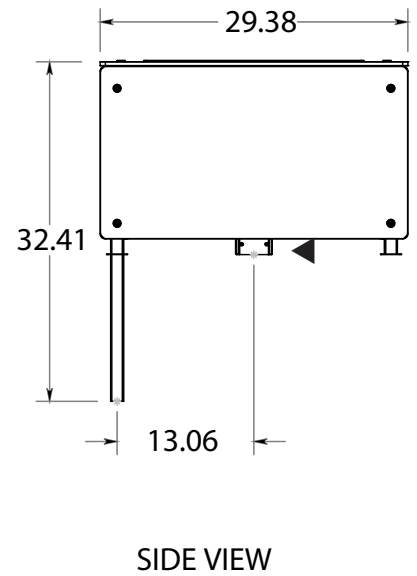
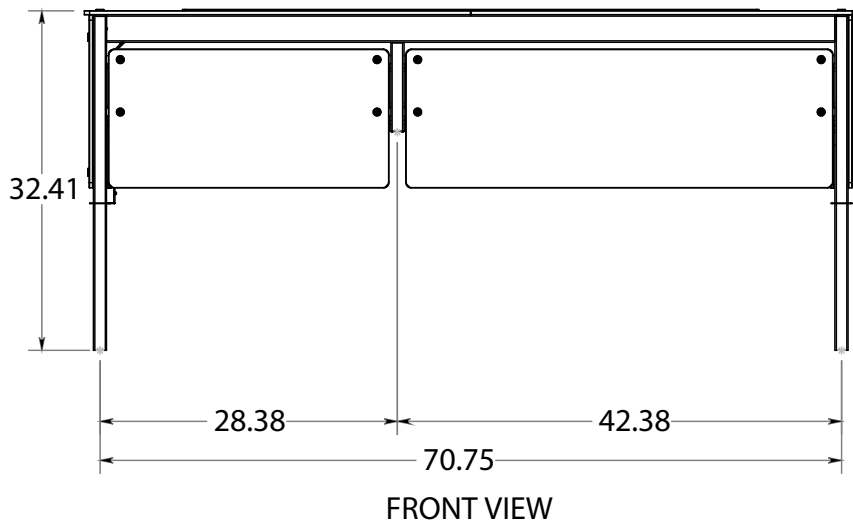
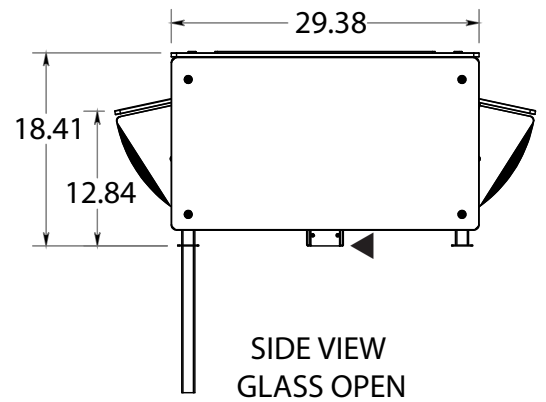
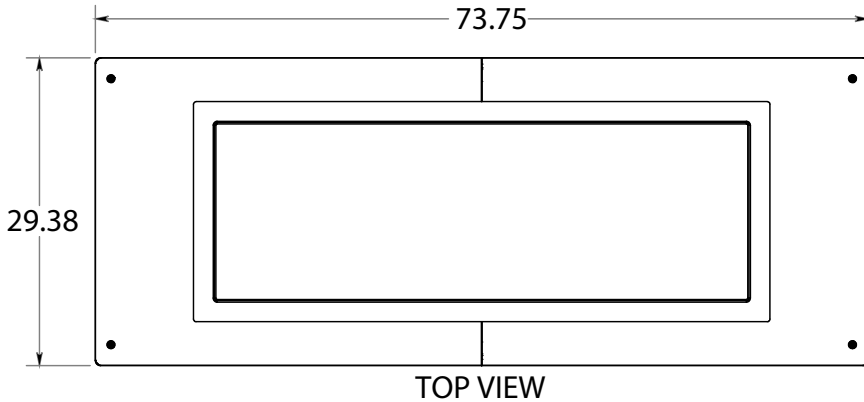
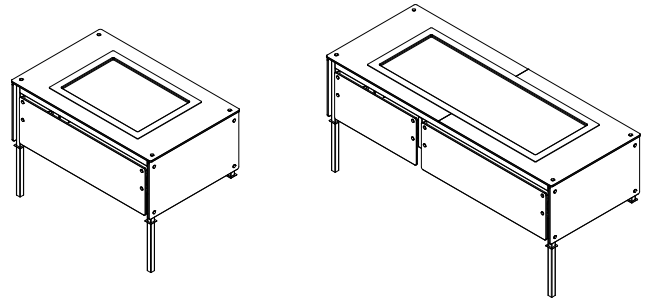

BGA1-74-DS-OS Shown Above

Dimensions:

Freight Class: 100

Overall Height: 32.5 in. / 82.55 cm			Depth Overall: 29.38 in / 74.62 cm						
Model	Length		Section 1 Length		Section 2 - Length		Cube ft. Crated	Crated Ship Weight	
	Overall		CL/CL		CL/CL			lbs.	kg
	in.	cm	in.	cm	in.	cm			
BGA1-46-DS-OS	45.75	116.21	42.75	108.59	N/A		26	107	48.53
BGA1-60-DS-OS	59.75	151.77	56.75	144.145	N/A		34	128	58.06
BGA1-74-DS-OS	73.75	187.33	42.375	107.63	28.375	72.07	41	156	70.76
BGA1-88-DS-OS	87.75	222.89	42.375	107.63	42.375	107.63	49	184	83.46

BGA1 = Single Shelf
DS = Double Sided
OS = Over Shelf

Electrical Connection
 Electrical Specs for overshelf are located on Page 16



BGA2 Dual Shelf Double Sided with Over Shelf

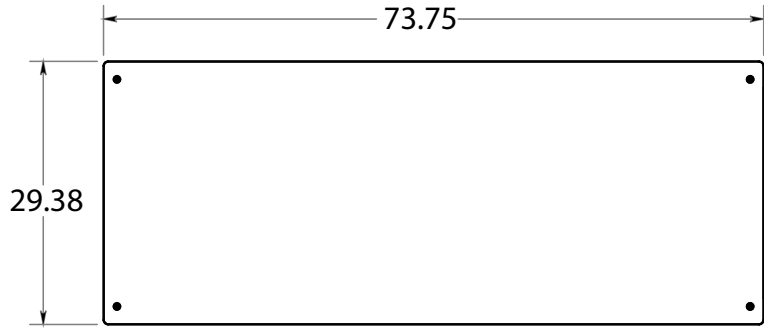
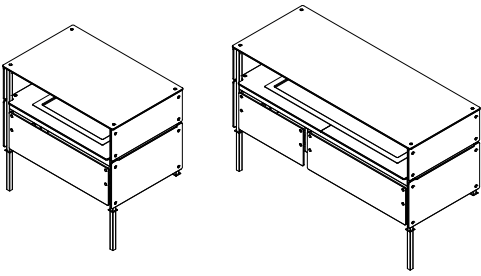

TOP VIEW

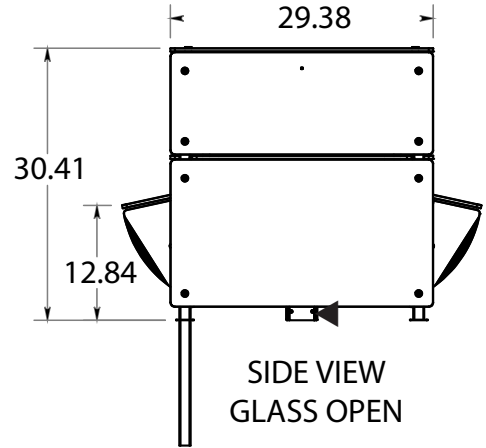

SIDE VIEW
GLASS OPEN

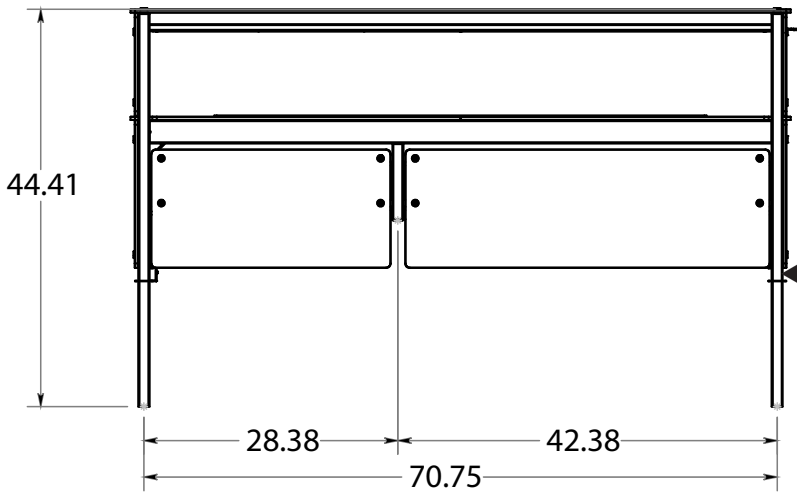

FRONT VIEW

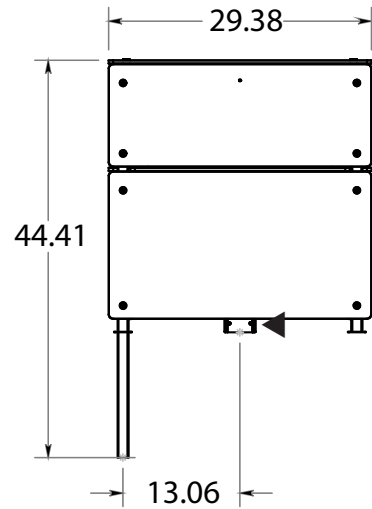

SIDE VIEW

BGA2-74-DS-OS Shown Above

Dimensions:

Freight Class: 100

Electrical Specs:

Overall Height: 44.5 in./113.03 cm		Depth Overall: 29.38 in/74.62 cm									
Model	Length		Section 1 Length		Section 2 - Length		Cube ft. Crated	Crated Ship Weight		120 Volt Electrical Specs LED Only NEMA 5-15P	
	Overall		CL/CL		CL/CL			lbs.	kg	Watts	Amps
	in.	cm	in.	cm	in.	cm					
BGA2-46-DS-OS	45.75	116.21	42.75	108.59	N/A		35	128	58.06	19.2	0.16
BGA2-60-DS-OS	59.75	151.77	56.75	144.145	N/A		46	149	67.59	33.6	0.28
BGA2-74-DS-OS	73.75	187.33	42.375	107.63	28.375	72.07	56	177	80.29	40.8	0.34
BGA2-88-DS-OS	87.75	222.89	42.375	107.63	42.375	107.63	67	205	92.99	48.0	0.40

BGA2 = Dual Shelf
DS = Double Sided
OS = Over Shelf

◀ Electrical Connection
Electrical Specs for overshelf are located on Page 16

BGA Food Guard Series

Over Shelf Specs

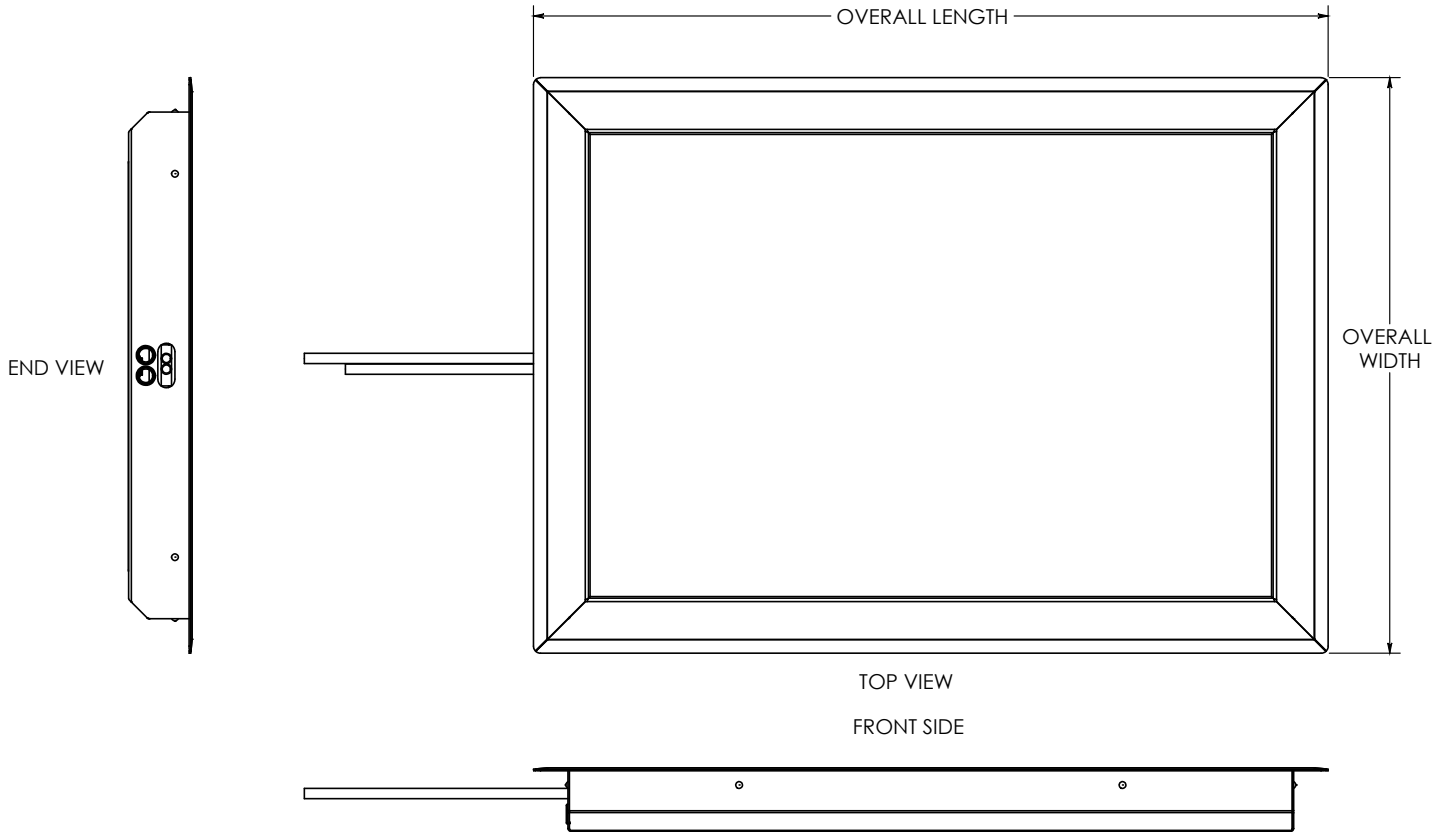
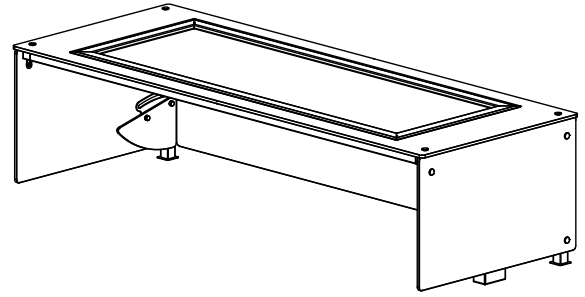

ELECTRICAL SPECIFICATIONS:

Model		120 Volt - HZ 60			Model		120 Volt - HZ 60			Model		120 Volt - HZ 60		
		Amps	NEMA	Direct Wired			Amps	NEMA	Direct Wired			Amps	NEMA	Direct Wired
HFO1-SL	Hot Frost - Slim Line	5.8	5-15	Terminal Block	HTO1-SL	Hot Top Only - Slim Line	2.8	5-15	Terminal Block	FTO1-SL	Frost Top Only - Slim Line	5.8	5-15	Terminal Block
HFO2-SL	Hot Frost - Slim Line	5.8	5-15		HTO2-SL	Hot Top Only - Slim Line	5.3	5-15		FTO2-SL	Frost Top Only - Slim Line	5.8	5-15	

Note: Must be mounted in a BG/BGA food guard and only available in a Duke Thurmduke or CounterCraft Counter

TOUCHSCREEN CONTROL SPECIFICATIONS

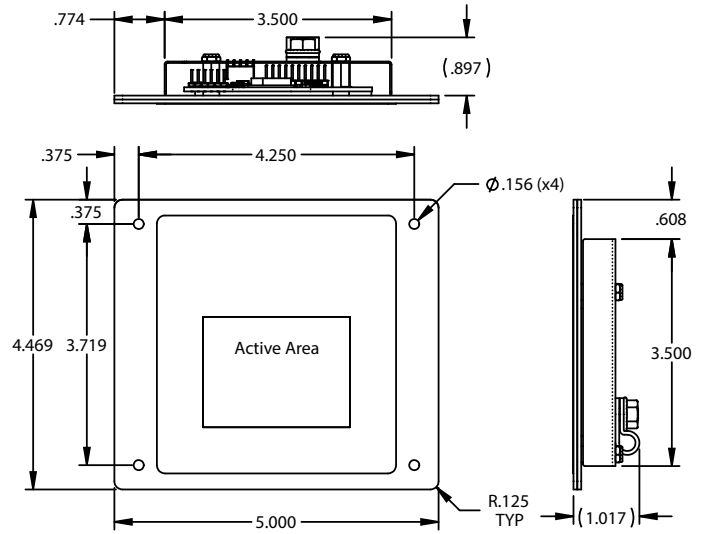
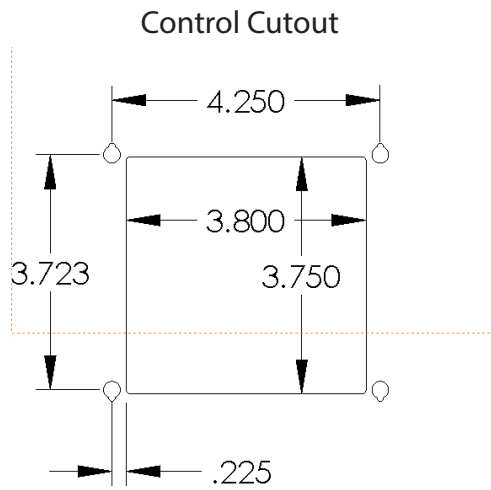

WIRE DIAGRAMS

Touchscreen Control - Heat and LED

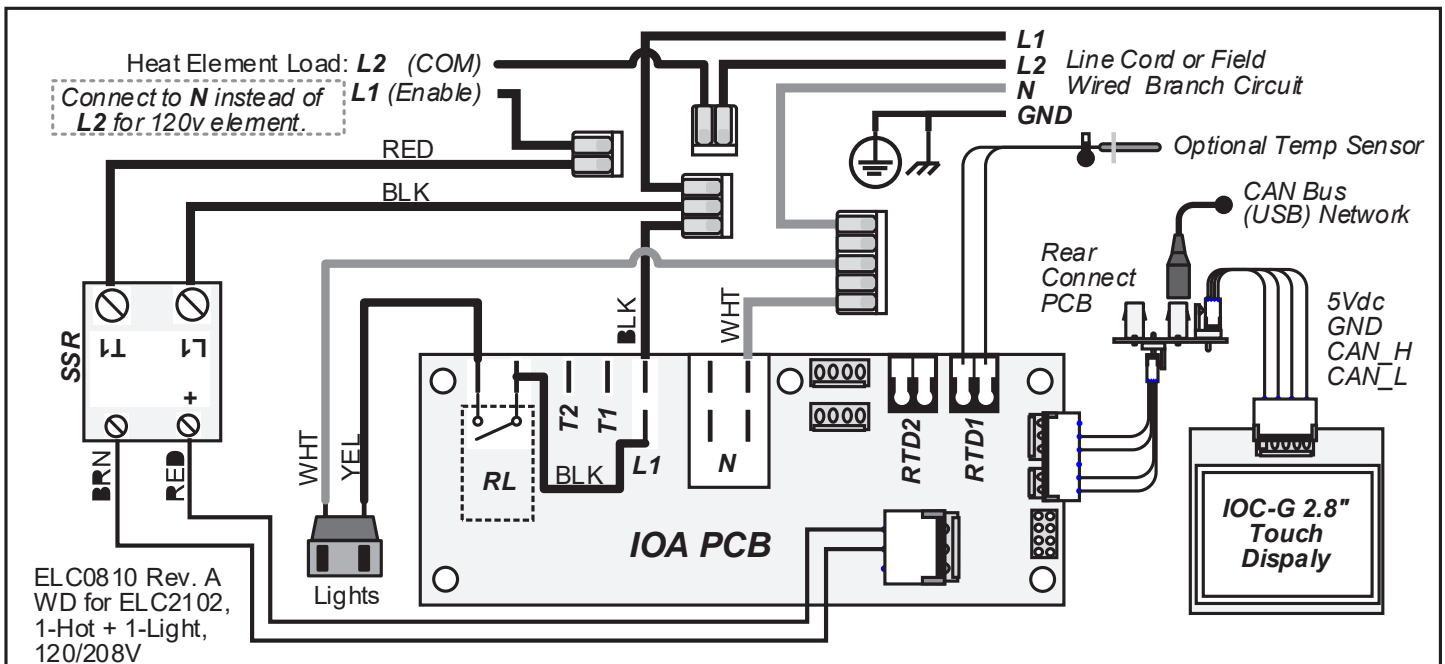

WIRE DIAGRAMS

Touch Screen - Lights Only

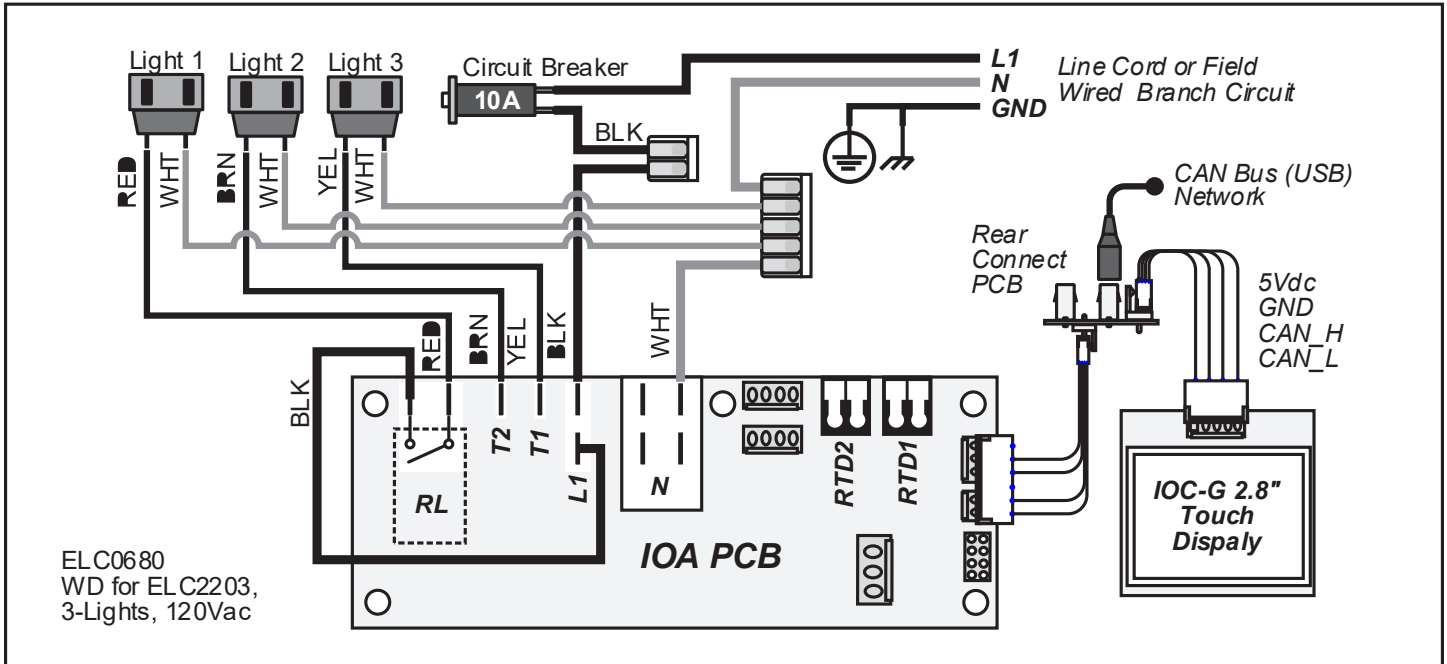

Mechanical Control

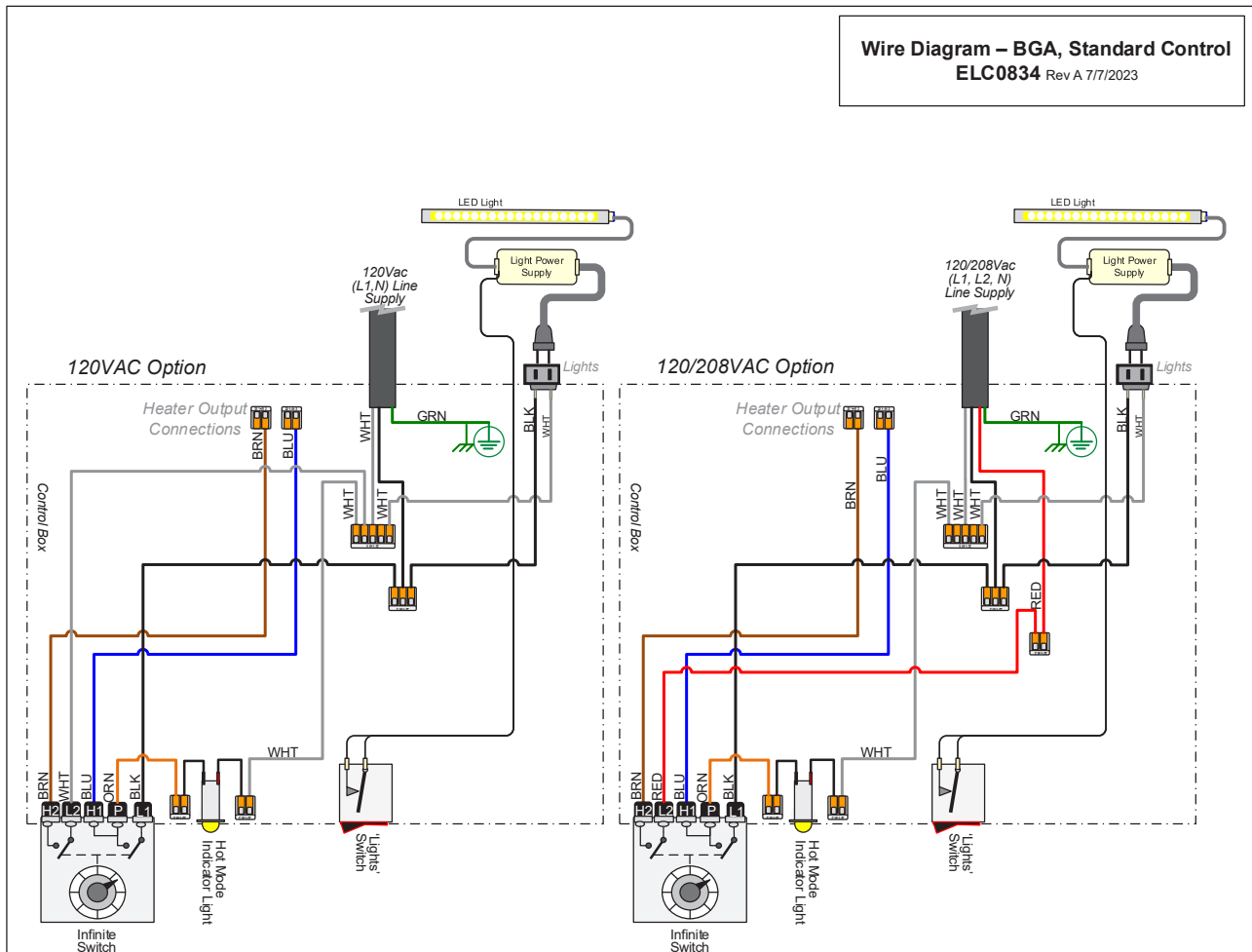

INSTALLING MECHANICAL CONTROL

1

Remove four (4) screws holding the front panel on the new control.

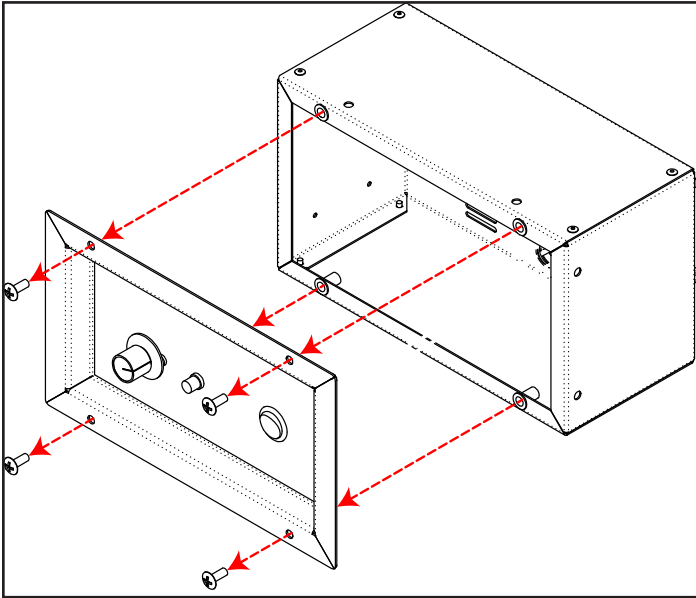

3

Mount control box along bottom of apron.

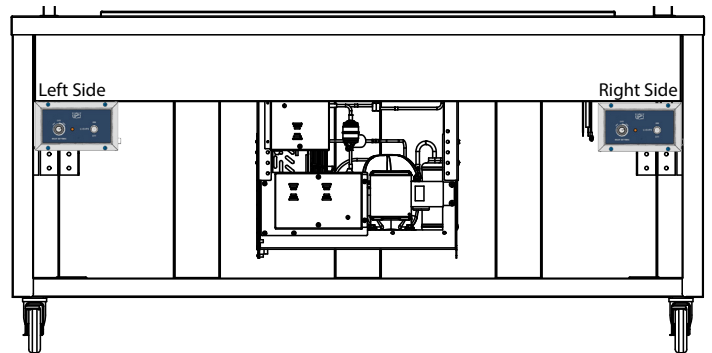

2

Control box can be mounted by either end or the top using two (2) pre punched holes in control box.

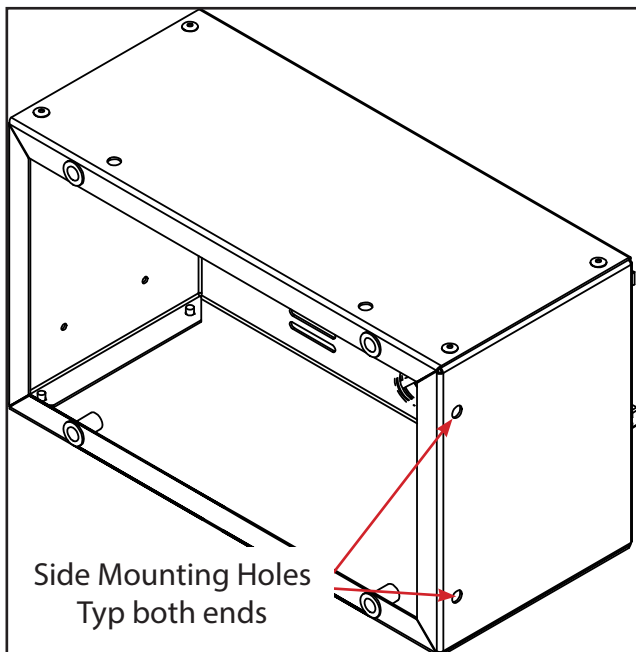

4

Re-Install control box cover with four (4) screws removed in step 1.

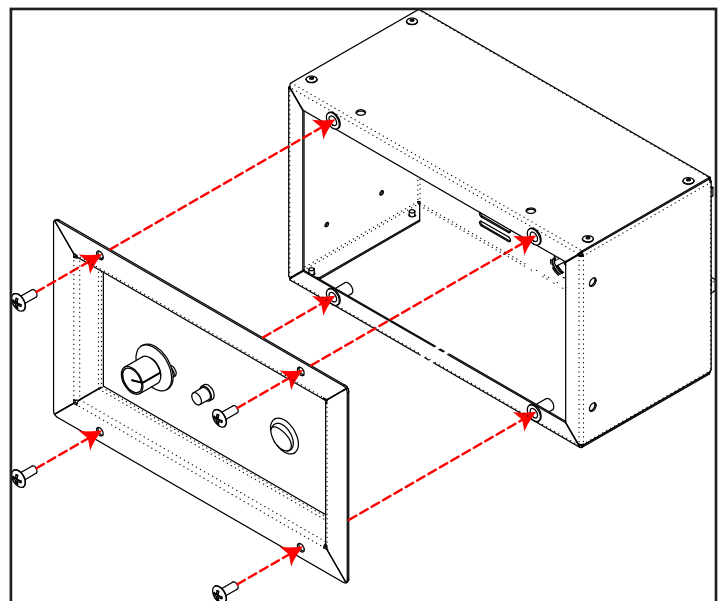

MECHANICAL CONTROL OPERATIONS



Note: Your Control may look different based on your unit.

HOT SHELF

- Turn the Hot Control Knob to the desired level of heat
- Unit will begin to heat
- The amber light will come on

LIGHTS

- For lights flip switch to ON

FRONT GLASS OPERATION

Top glass shelves are not intended to hold heavy loads.

CAUTION Do not exceed 75lbs. total weight of all display items.

To change position of front glass, lift up slightly and rotate up or down.



Note: No tools are required to move front guard.

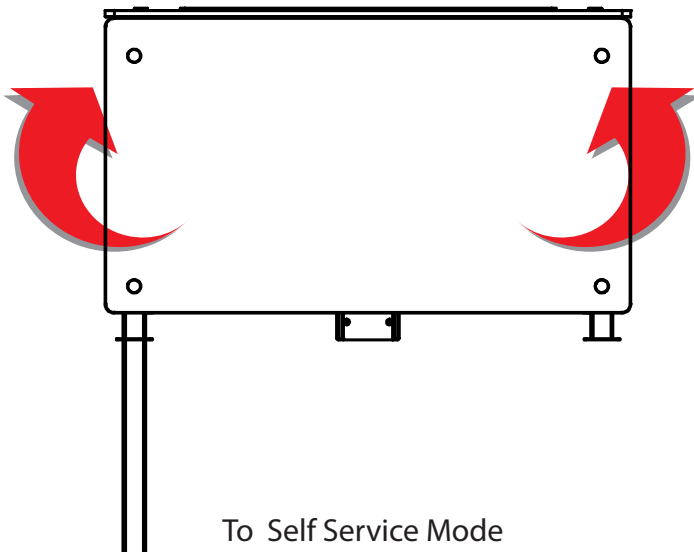

To Self Service Mode

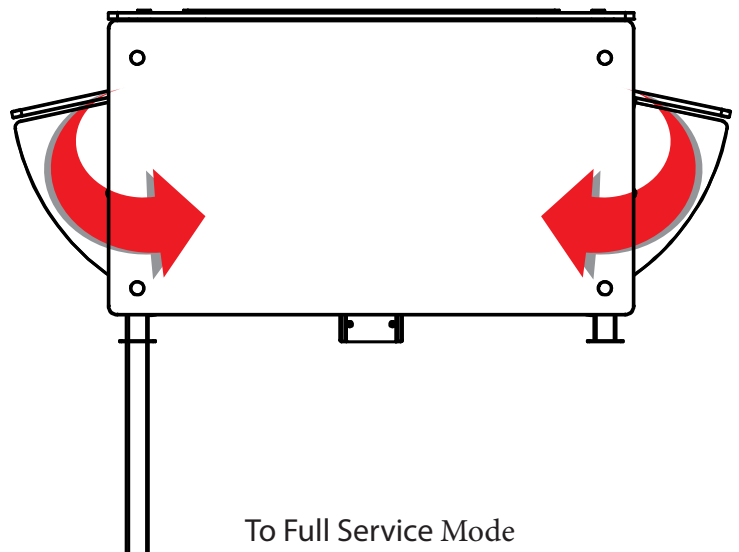

To Full Service Mode

THROUGH MOUNT

CAUTION

**CHECK YOUR MODEL'S SPEC SHEETS FOR CL/CL
SUPPORTS DIMENSIONS**

CAUTION

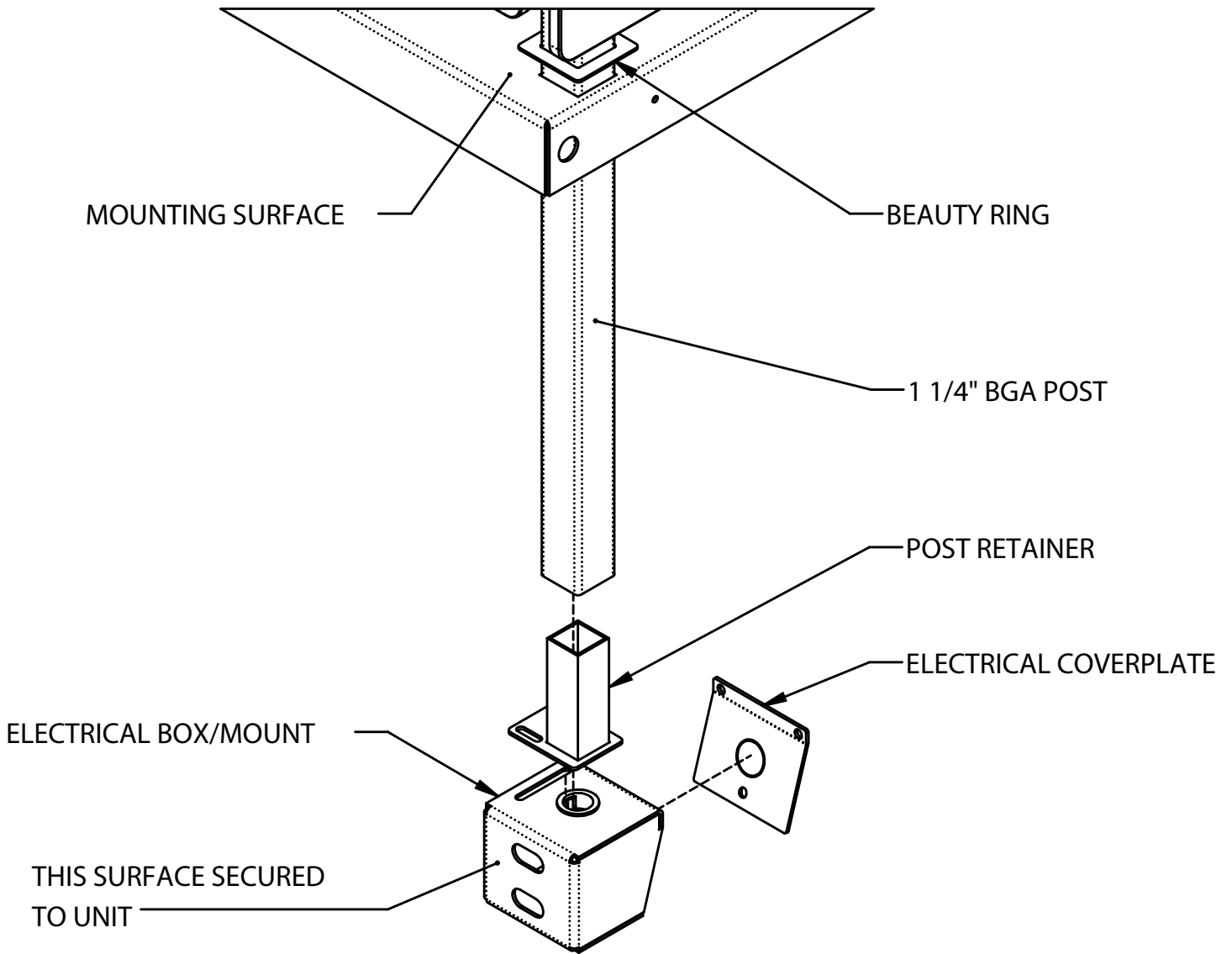

Customer Side Through Post Mount

FLUSH MOUNT

CAUTION

CHECK YOUR MODEL'S SPEC SHEETS FOR CL/CL SUPPORTS DIMENSIONS

CAUTION

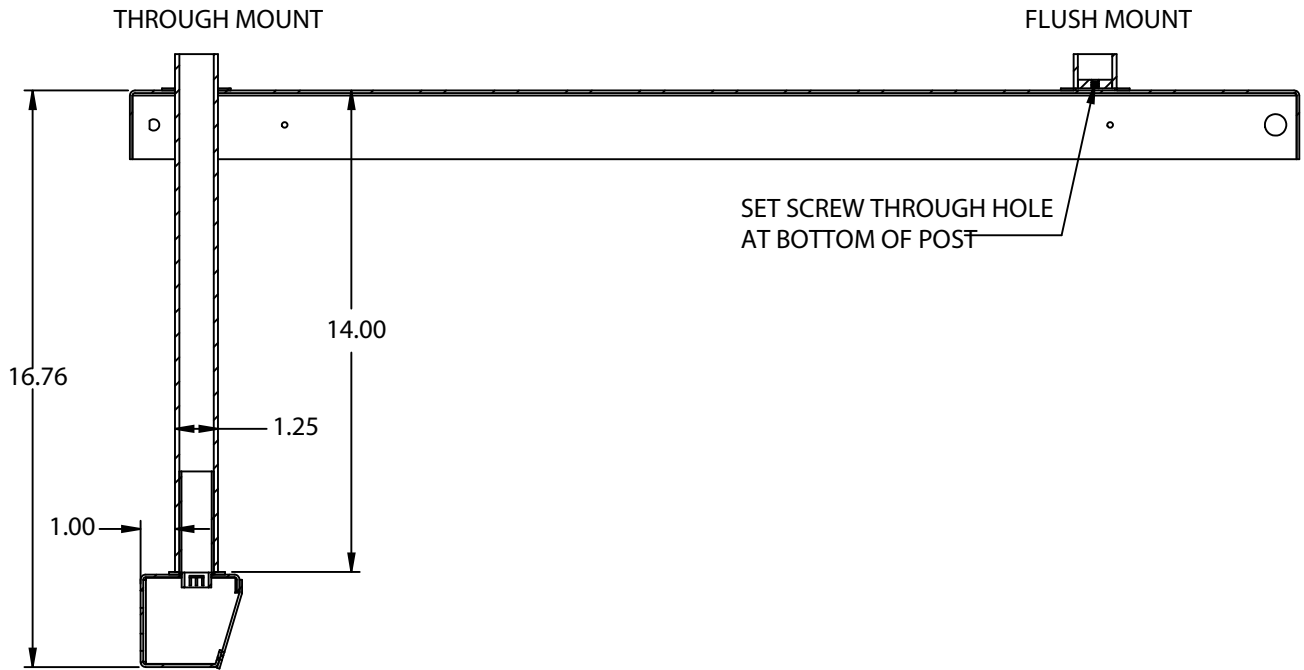

CHASE CUTOUTS

CHASE DETAILS

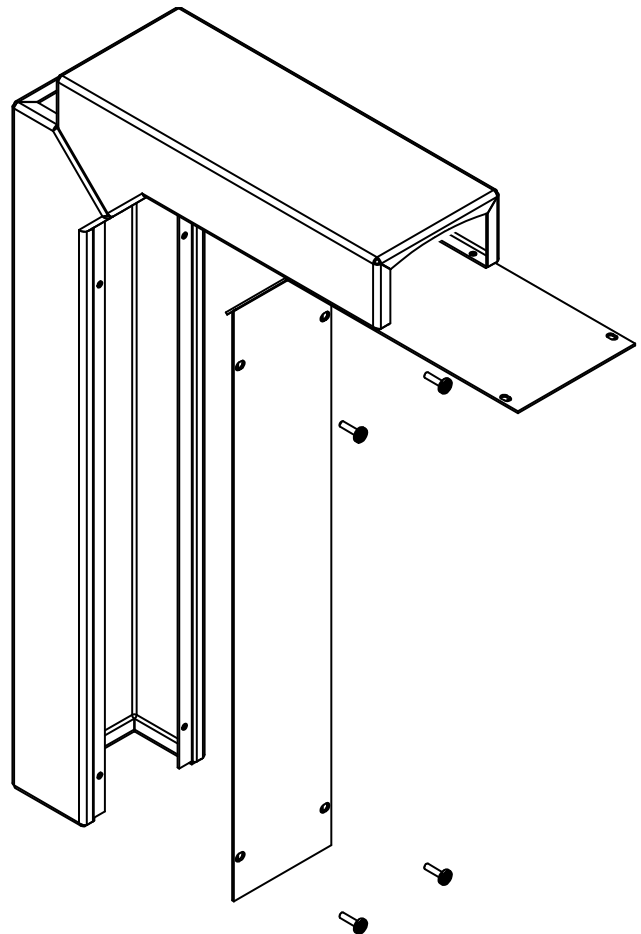
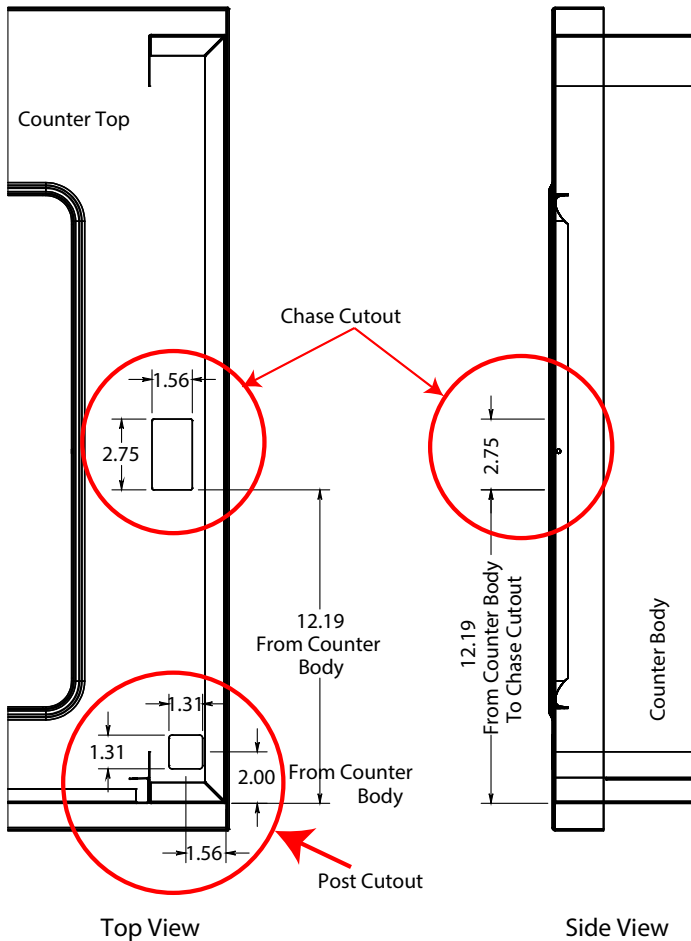

GLASS INSTALLATION

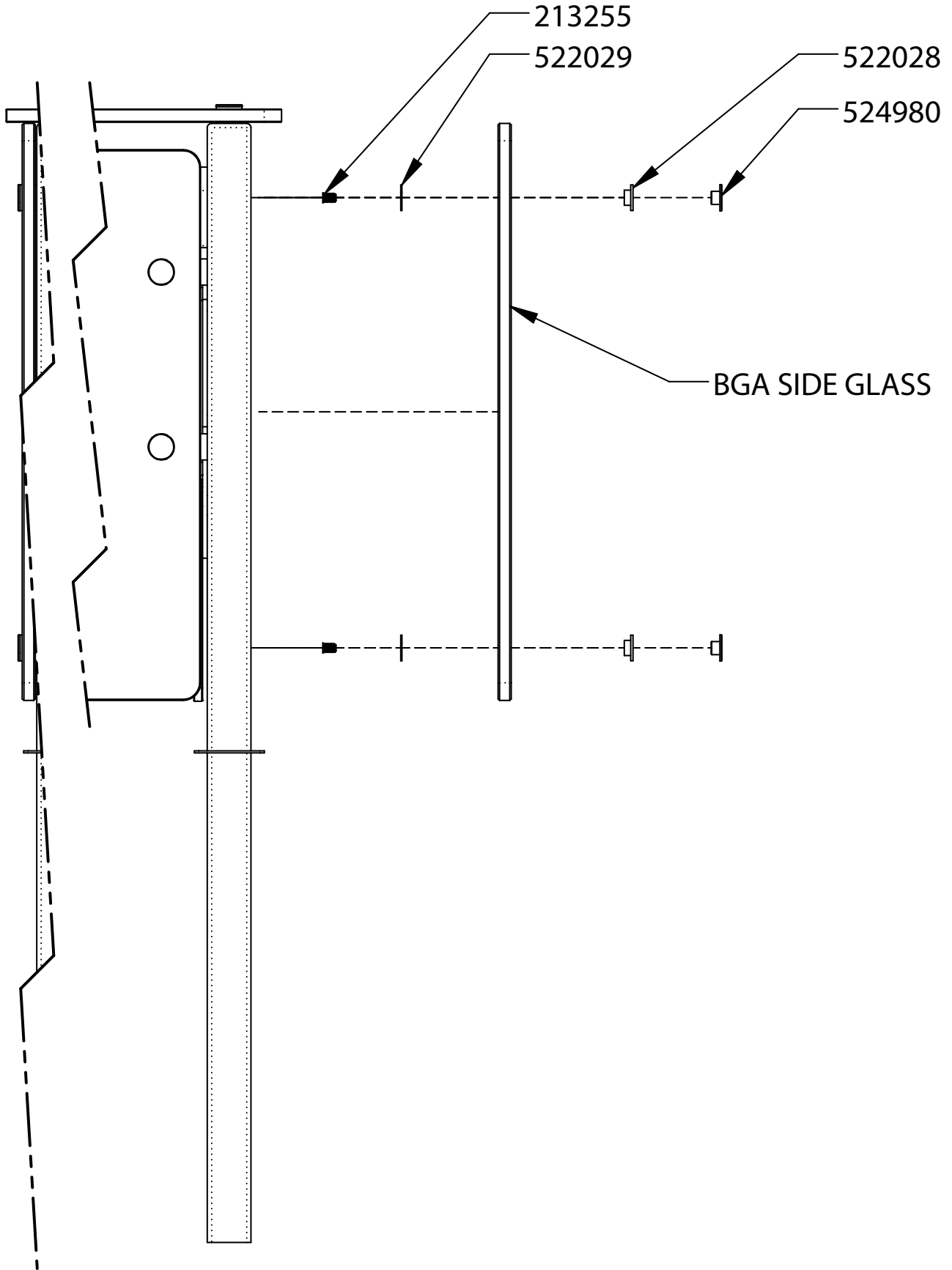

HEATER INSTALLATION

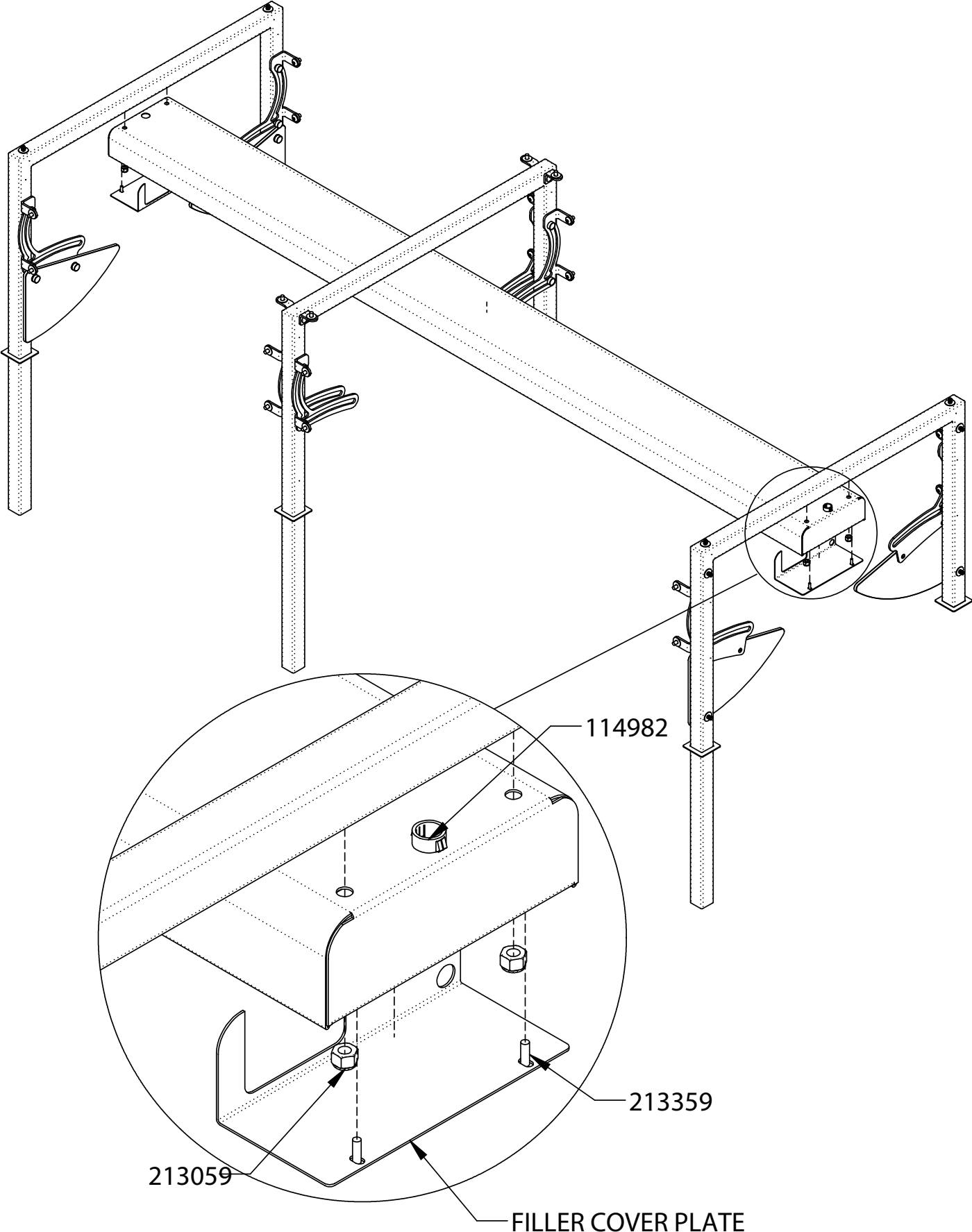

MAINTENANCE

⚠ WARNING

The device is not suited for direct washing with a water jet.
Therefore, do not use a pressure water jet to clean the device!

CAUTION

Before cleaning turn the device off and allow the unit to cool, if applicable. If not followed could cause personal injury.

CLEANING STAINLESS

- Remove all food products from below unit.
- Do not use caustic cleaning agents
- Wipe the unit down with warm soapy water.
- Do not use abrasives, steel wool or similar that could scratch the surface of the Stainless.
- After cleaning, use a soft cloth to dry the surface.

CLEANING GLASS

- Remove all food products from below unit.
- Use an approved glass cleaner to clean all glass.
- After cleaning, use a soft cloth to dry the surface.
- Do not use abrasives, steel wool or similar that could scratch the surface of the Glass.



Your Solutions Partner

Duke Manufacturing Co.

2305 N. Broadway
St. Louis, MO 63102

Phone: 314-231-1130
Toll Free: 1-800-735-3853
Fax: 314-231-5074

www.dukemfg.com