

Features

The FF-C15-SYS is a single unit water treatment system designed to reduce sediment, chlorine, taste and odors. The system filters to 1 micron and provide exceptional taste for beverage and carbonators.

Benefits

- ▶ High quality activated carbon to greatly reduce corrosion, bad tastes and odors
- ▶ Reduces costly equipment maintenance
- ▶ Fast-Fit cartridge system for quick change out.
- ▶ Full port shut off valve
- ▶ Pressure line gauge



Application

**Cold & Hot Beverage, & Carbonators
up to 2 gpm flow rate**



Specifications

Dimensions	21 X 5 X 4.5
Connection	3/8" FNPT standard - Can also have 3/4" GH upon request
Max. PSI	125
Max Temp.	100° F
Flow Rate	2.0 gpm
Sediment Reduction	1 micron
Shipping Weight	7 lbs.

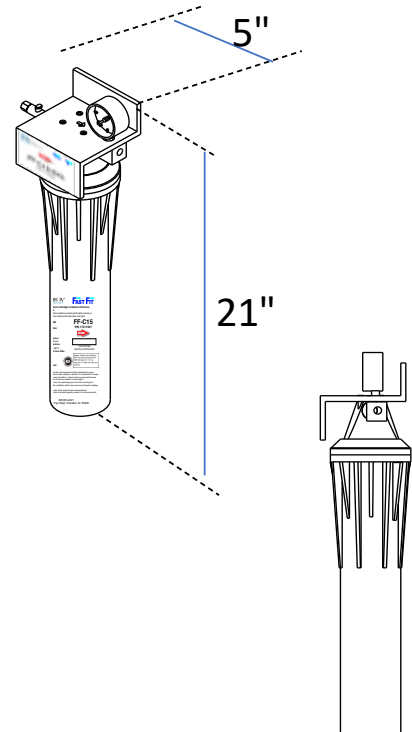

Replacement Cartridges

Models:

FF-C15
P/N 17511501

All Fast Fit cartridges should be changed out every six months or when there is a reduction in water pressure. Filter life depends greatly upon the quality of water. This product is for commercial use only and must be installed and maintained according to manufacturers guidelines www.systemsiv.com or the warranty can be voided.



Distributor/Dealer Info:

ANSI/NSF International Standards

Model FF-C15 cartridge tested and certified by NSF International against ANSI/NSF Standard Standard 53 for health affects.