

Endura[®] XL Grease Interceptor

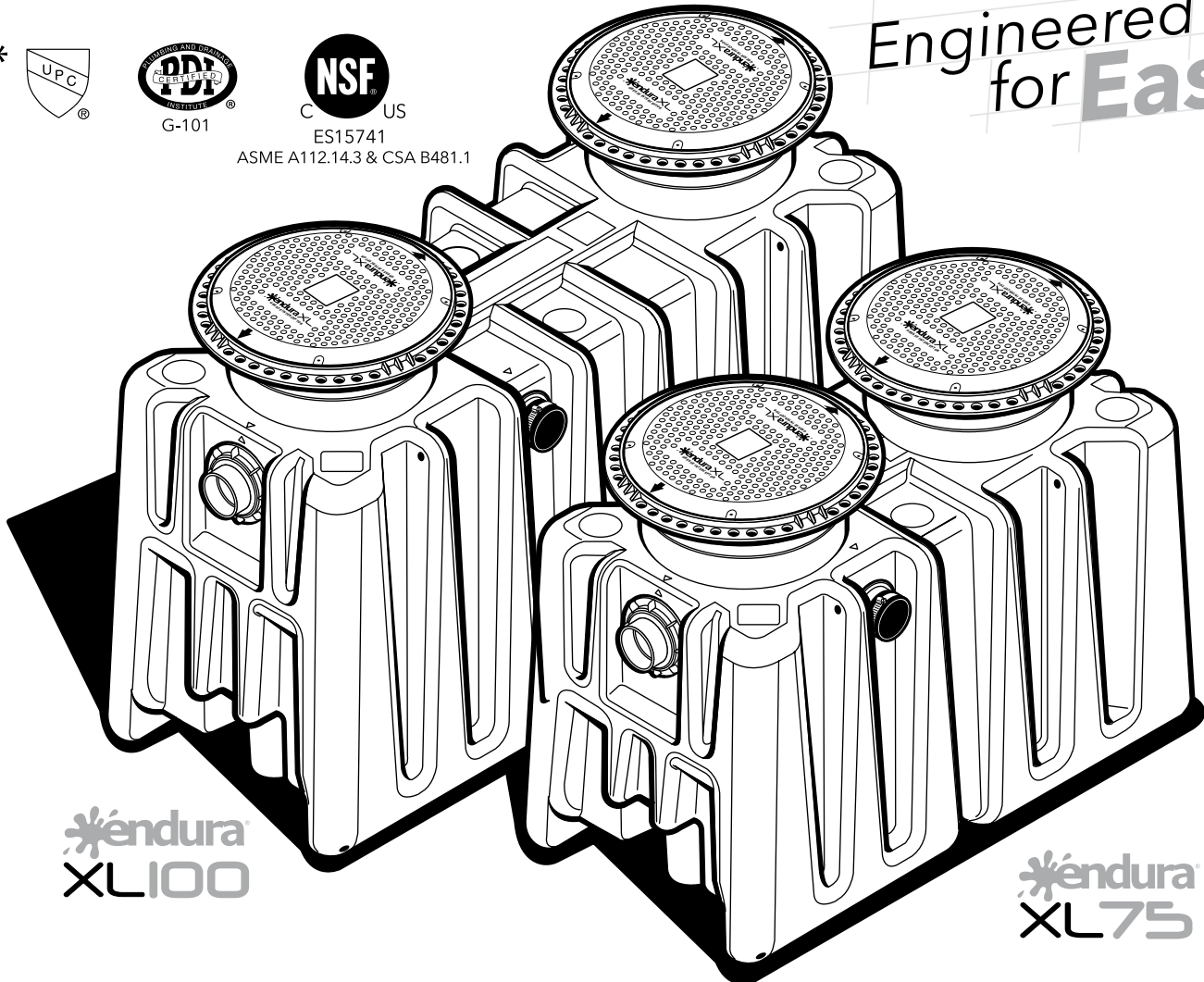

C US
ES15741
ASME A112.14.3 & CSA B481.1

Engineered
for **Easy**



Endura[®]
XL100

Endura[®]
XL75

INSTALLATION, OPERATION & MAINTENANCE



WARNING!

**DO NOT PRESSURE TEST
RISK OF SERIOUS INJURY**

As a plumbing appurtenance your Endura[®] grease interceptor **MUST** be isolated from the drainage system in the event that final drain testing or other system pressure testing is required. **DO NOT under any circumstances subject your interceptor to pressure test (Air, Water or Otherwise).** This action will result in damage to the unit, invalidate your warranty and could cause serious bodily injury.

Technical Support
tech-support@endurainterceptor.com

Canada
Tel: (705) 726-3361
1-800-461-1771
Fax: (705) 726-2186

U.S.A
Tel: (303) 373-1918
1-888-461-5307
Fax: (303) 373-1923

Features Overview

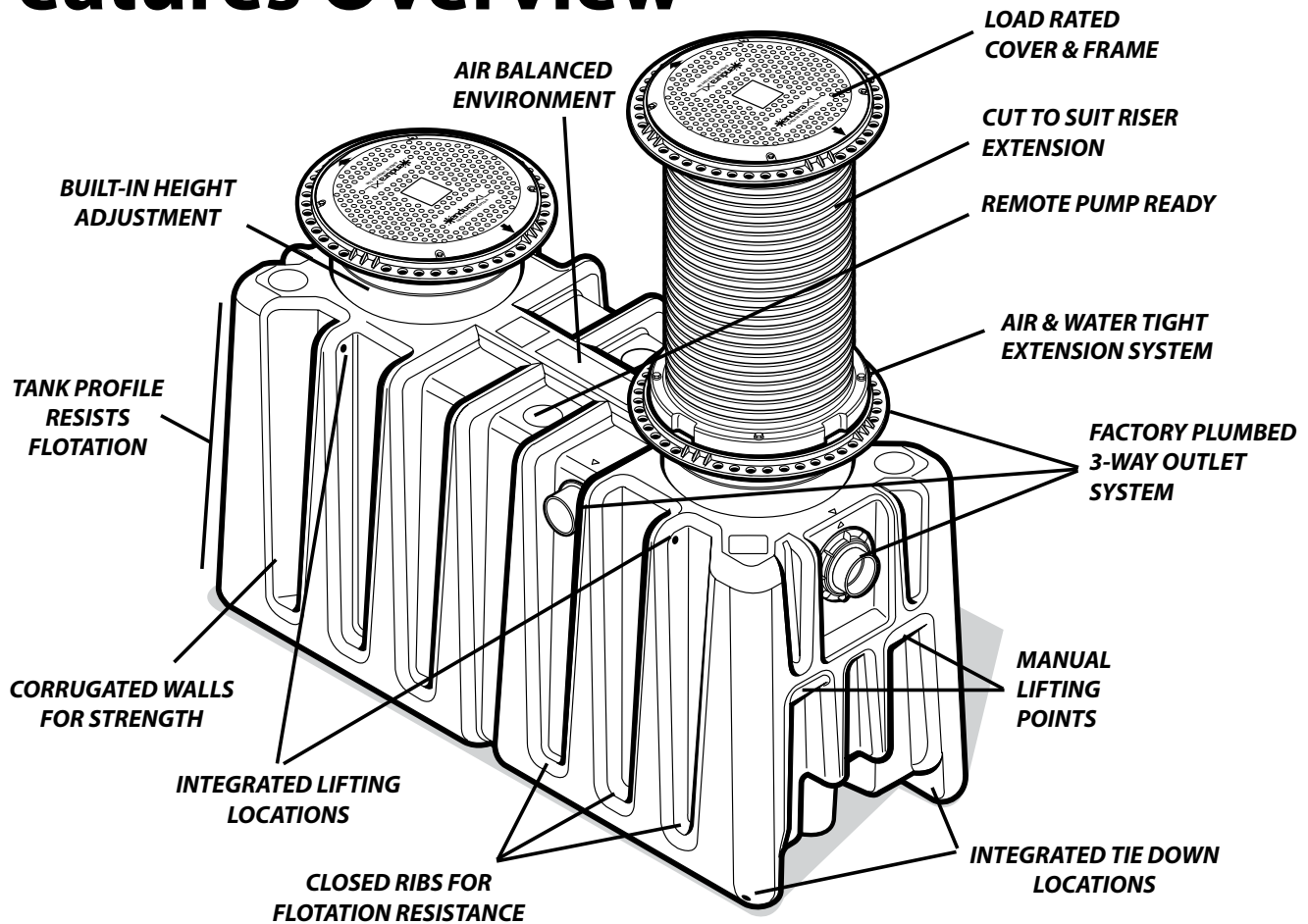

About Your Purchase:

The Endura® XL grease interceptor and its associated products are the latest addition to the proven line of Endura® Grease Management products.

We have spent many thousands of hours in the development of Endura® XL, our aim being simple – to produce the industry’s best Hydromechanical Grease Interceptor.

From the ground up, Endura® XL has been ‘Engineered for Easy’. Working with distributors, installers, engineers, jurisdictional officials, pumpers and of course restaurant operators across North America, we have taken all of the feedback gained and rolled it into one comprehensively designed solution to meet as broad a range of these requirements as possible.

Endura® XL is the most widely evaluated and approved hydromechanical interceptor in the current marketplace, being successfully tested by independent third parties to meet all requirements of PDI G-101, ASME A112.14.3 (Type A & C) / NSF ES15741 and CSA B481.1.

*Endura brand products manufactured by Canplas Industries.

Table of Contents

	Page		Page
Features Overview	2	Installer Checklist	14
Glossary	3	Operation	15
Quick Start Installation Guide	4	Maintenance	16
Technical Information	6	Pumper Checklist	18
Installation Specifications	8	Trouble Shooting	19
Installation	11	Frequently Asked Questions	20
Installation - Flow Controls	12	Warranty	23
Remote Pump (optional)	13	Registration Card	24

Glossary of Terms

HGI: Industry abbreviation for Hydromechanical Grease Interceptor. By definition an HGI is designed to use managed flow, air entrainment and specifically designed features to provide an enhanced level of separation efficiency, removing non petroleum FOG (Fats, Oil and Grease) from a transition flow of waste water, generated by commercial foodservice activities (Restaurants, Cafeterias, Institutional Kitchens, Sandwich Shops and Coffee houses for example). HGI's are performance tested for efficiency of grease separation based on National Standards.

Operational Cost Index =1

GGI: Industry abbreviation for Gravity Grease Interceptor. By definition a GGI has a minimum of 350USG capacity and in operation 500USG to 1500USG of capacity are most common. No flow control device. Separation of FOG based on capacity and retention time of water (minimum 30 min. to exchange volume). At this time no performance Standards are published for GGI's.

Operational Cost Index HGI = 5 GGI = 10+

GRD: Industry abbreviation for Grease Removal Device. Designed firstly as an HGI, a GRD uses a heat source and a timed or sensor based skimming (or draw-off) device to remove accumulated FOG from the separation chamber into an external container for collection and disposal. These units require daily maintenance for management of food solids. **Operational Cost Index HGI = 2.5 GGI = 5**



– Available online



– Mobile Friendly



BMP – Best Management Practices

25% Rule: The rule of thumb, sometimes mandated by jurisdiction, used to determine frequency of pump out for GRAVITY GREASE INTERCEPTORS. The 25% refers to the combined volume or retained FOG and food solids which shall not exceed 25% of the working volume of the interceptor. This rule should not typically be applied to HGI's particularly those with extended capacity.

Cost Index: A way of indicating the relative cost of different types of interceptor to each other for broad comparison purposes. This includes product purchase, installation cost and typical maintenance.

Air Entrainment: Mixing of air with Influent using a flow control device. Air and grease are attracted to each other, the air wanting to separate more easily than grease. Because they become mixed together the air increases the efficiency of separation.

Effluent: Waste water containing little to no FOG, being discharged out of the interceptor.

Influent: Waste water containing uncontrolled and variable levels of FOG based on the nature and practices of the foodservice operation.

Separation Chamber: Zone inside the interceptor where grease separates from water and is retained.

AHJ: Authority Having Jurisdiction. This can be one or more government departments - for example plan check/review, building, plumbing, pretreatment, sewer and waste water. Bottom line...those who enforce the rules and regulations.

Quick Start Guide



Before you begin, be sure to review this document in full for important information regarding the installation process. Also, ensure that the interceptor purchased is correctly specified and sized for the intended installation. Be sure to reference and be familiar with local code and municipal FOG Program requirements. The Authority Having Jurisdiction (AHJ) can be your best friend and your worst enemy.

1. Prepare your installation area

If installing in-floor or below grade excavate as required to accommodate the interceptor and ensure safe working practices. Refer to Installation Specification section of this document (See Page 8-10).

2a. In ground/floor

Remove all packaging, including the skid. Confirm flow direction, lower in and level interceptor accounting for anticipated surface finish requirements.

Note: For installations where high ground water is anticipated, once located pour at least 8" of concrete on top of your prepared base, to fill an area around the perimeter of the tank. This will prevent flotation. For alternative methods of anchoring (See Page 8-10).

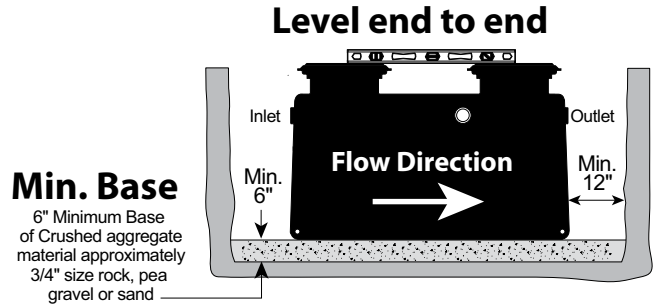

Level side to side

Anchoring (if required)

Concrete Anchor Base (if anchoring is required)

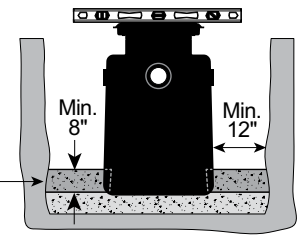

2b. On floor/floor below

Remove all packaging including the skid. Locate the interceptor so as to allow for accessibility when conducting maintenance and regular cleaning. Set the interceptor on a firm, level surface ensuring tank is equally supported.



When full the weight of the tank is significant (XL75 Approx. 1300lbs [590kg]), XL100 Approx. 2150lbs [975kg])

For suspended application engineering service by a qualified engineer will be necessary. A minimum safety factor of 2 shall be applied in calculation/design.

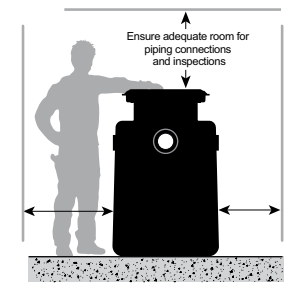

3. Select preferred outlet connection

Connect your influent drain to the tank inlet ("IN"). Select the preferred outlet connection from the pre-plumbed connection ports offered – marked "OUT". Side connection is accessed by removal of the caps supplied, that cap then being used to seal the end outlet.

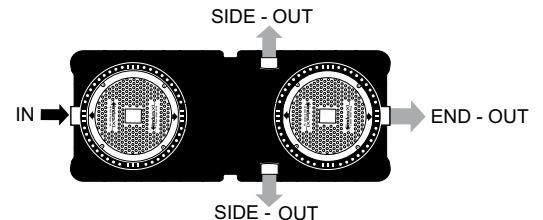

4. Installations with External Flow Control (PDI G-101/ASME A112.14.3 - Type A)

For PDI G-101/ASME A112.14.3 (External Flow Control)– Install the flow control device (purchased separately) upstream, after the last branch connection discharging to the interceptor. A maximum of 25ft from last branch discharge to the entry of the interceptor is required to meet published recommendations. See Page 12 for connection formats.

See page 6 for cleanout part numbers



Plumbing code typically requires provision of a cleanout to grade immediately before and after the inlet and outlet connections.

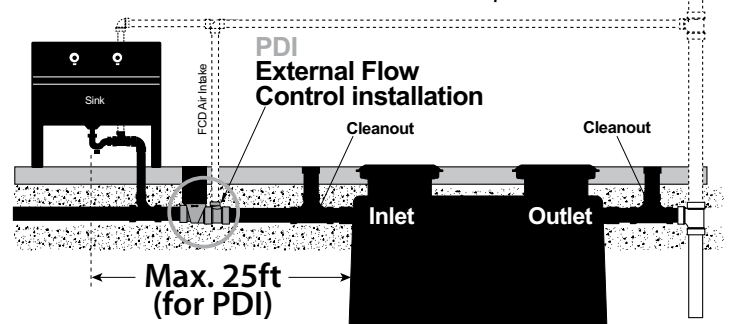

5. Fill tank

Fill tank with water to static water level. This provides stability and crush resistance during backfilling. Check connections made for any leaks.



For inspection testing DO NOT PRESSURE the tank. Plug lines inside interceptor to test upstream and downstream integrity.

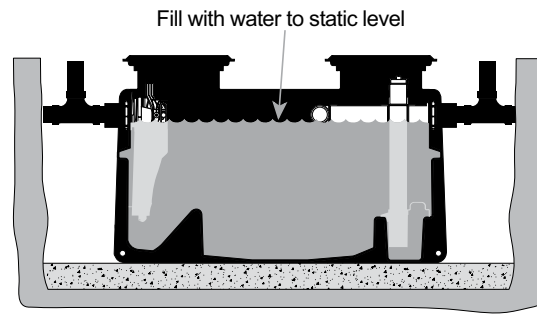

WARNING!
DO NOT PRESSURE TEST. RISK OF SERIOUS INJURY.

6. Replace cover(s) and backfill

Replace cover(s) and protect with cardboard or similar during back filling. Backfill per specification (See Page 8).

If installing Remote Pump option do so now (See Page 13)

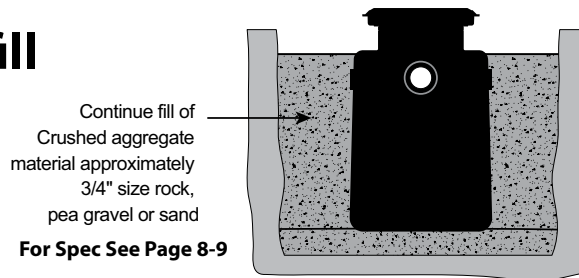

7. Riser Extensions (optional)

Depending on your application, extend the tank risers (using 40100AX35) to grade/floor level. Be sure to account for finishing. (Refer to Manual 40100X35-8 – Riser Extension Installation Guide)

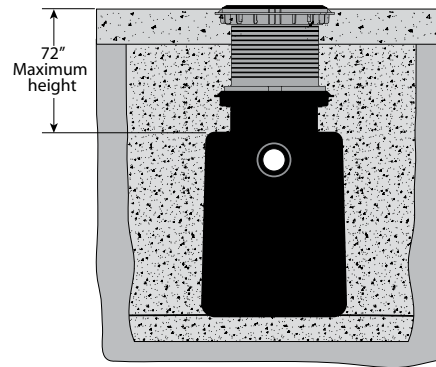

8. Finish to grade

For in ground applications with vehicular traffic, the upper 8" requires a reinforced concrete slab. Refer to the Installation Specification section of this document (See Page 8-9). This details backfill materials and concrete reinforcement requirements.

Reinforced concrete pad for traffic rated installations

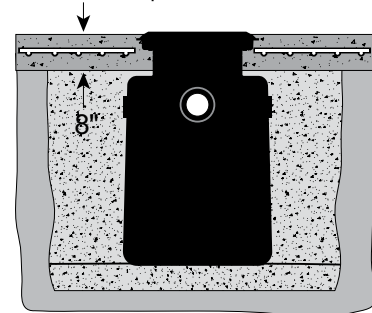

9. Completion documentation

Having completed installation and successful inspection, hand-over to the client all installation documentation, with page 14 completed. Fill out your sections of the Limited Lifetime warranty registration (See Page 24).

If submitting on behalf of your client you can do so at www.EnduraWarranty.com or by sending to the locations shown on the back cover of this document.

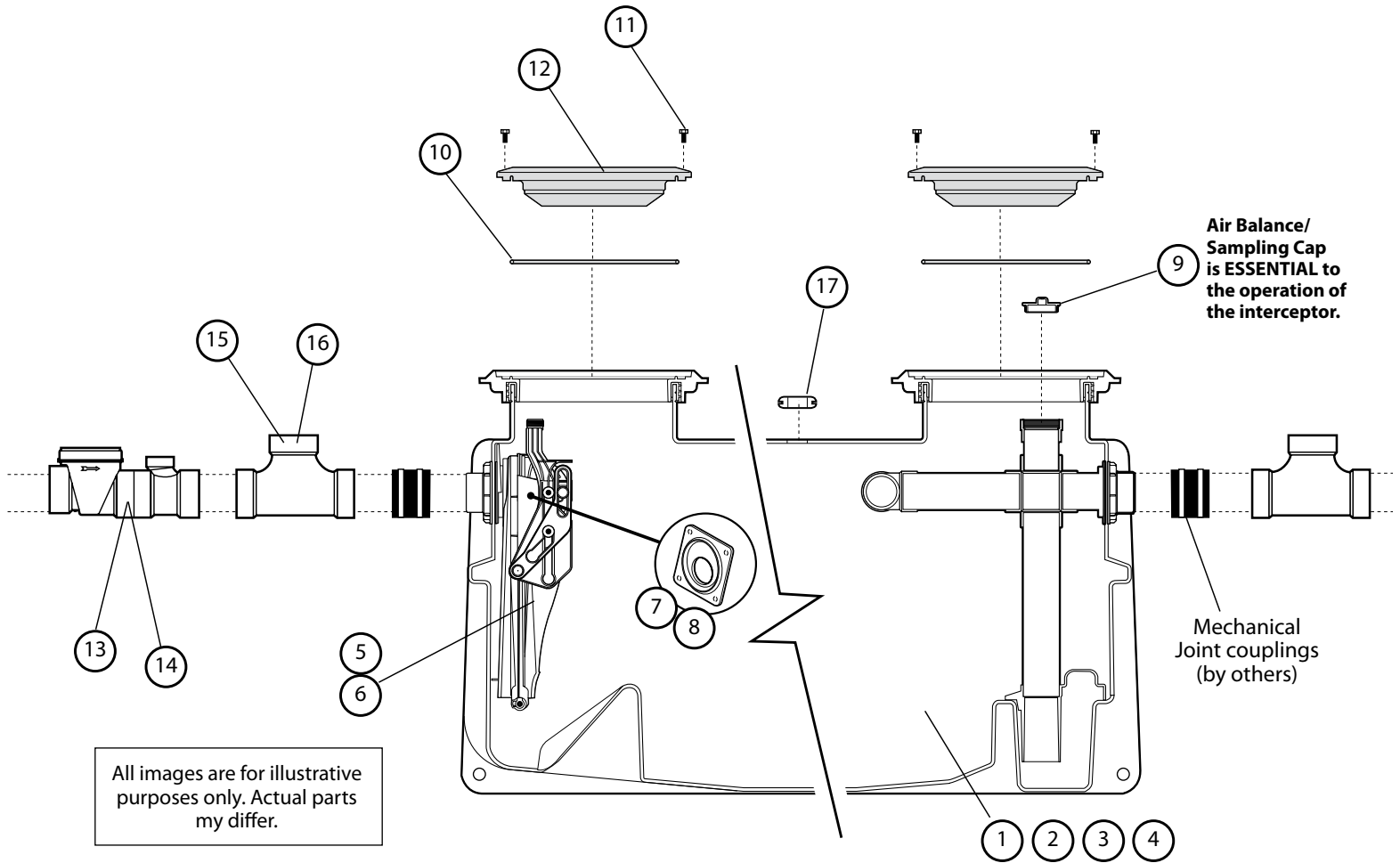

Parts Overview

Endura® XL Tank Components			
Item #	Description	Qty	Part #
1	Endura® XL 75gpm tank 4" Spigot connections	1	4075A04
2	Endura® XL 75gpm tank 4" Threaded connections	1	4075A04T
3	Endura® XL 100gpm tank 4" Spigot connections	1	40100A04
4	Endura® XL 100gpm tank 4" Threaded connections	1	40100A04T
5	75gpm Replacement Dynamic Baffle Assembly	1	4075ARDB
6	100gpm Replacement Dynamic Baffle Assembly	1	40100ARDB
7	Internal Flow Control Plate - 75gpm	1	4075-21
8	Internal Flow Control Plate - 100gpm	1	40100-21
9	Endura® XL Air Balance/Sample Port Cap	1	40100-33
10	Cover Seal	2	40100-4
11	Tamper Resistant Cover Fasteners	2	40100ARSB
12	Endura® XL Cover	2	40100ARCT

External Flow Control - for PDI/ASME Type A applications			
13	Endura® XL External Flow Control - 75gpm	1	4044275
14	Endura® XL External Flow Control - 100gpm	1	40442100

Parts Purchased - Recommended Installation			
15	4" 2-Way Cleanout - Sewer x Sewer x DWV	1	414150BC
16	4" 2-Way Cleanout - Sewer	1	414155BC

Parts Purchased - Remote Pump Application			
17	Remote pump pipe seal (optional)	1	40100TPS3

External Flow Control Dimensions

• Flow Control

Connection Iron Pipe Size (Solvent weld)	4" h x h
A	6.13" (155.7mm)
B	6.84" (173.7mm)
C	-

• Air Intake Tee

4" h x h
3.19" (81mm)
5.04" (128mm)
2.72" (69.1mm)

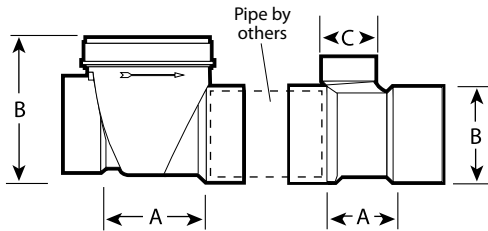

• Flow Control

• Air Intake Tee

Air Intake can be connected to building vent system or be independently to the atmosphere based on local code.

Specification:

Sample specification clause.

Contractor shall install a Endura® XL Hydromechanical Grease Interceptor (HGI), Part No. 40100A04 , 40100A04T , 4075A04 , 4075A04T (Indicate as applicable), and rated to 100GPM 75GPM (Indicate as Applicable) independently third-party certified to the current version of PDI G-101, ASME A112.14.3, NSF ES15741 and CSA B481.1. Approved alternate is permissible providing written compliance to the following is provided and validated.

Where an internal flow control is desirable and acceptable to the Authority Having Jurisdiction (AHJ), the interceptor shall be rated and approved to ASME A112.14.3 Type C. The flow control shall be accessible for cleaning and inspection up to the maximum burial depth of 72" regardless of the application and when requiring Riser Extension, the installing contractor will extend the opening device according to manufacturers published instructions. The outlet system will provide facility for connections to be made perpendicular to the inlet connection. Connection formats will be compliant with requirements of AHJ and the performance standards identified above. Contractor shall provide mechanical joint connectors or requisite materials to connect the grease interceptor to the drainage system, additionally making adequate provision for management of food debris and solids.

Interceptor shall be furnished with two (2) traffic rated access covers, maximizing internal visibility for inspection and maintenance when removed. These covers shall be capable of withstanding a proof load of 20,000lbs, being qualified for application at temperatures from -20°F to +100°F (-29°C to +38°C). The cover will be mechanically secured when operational.

The interceptor tank shall be constructed with seamless engineering thermoplastics, evaluated and approved to the material performance requirements of CSA B481.0

The interceptor shall additionally; operate with an air-balanced environment to equalize variation in internal pressures being controlled and maintained with an appropriately sized air balance means; be supported by a Lifetime Warranty against manufacturing defect.

For approved Plumbing & Drainage Institute (PDI) installation, an accessible flow control 40442100A , 4044275A 40442100AT , 4044275AT (Indicate as applicable) with molded orifice and removable access cap will be installed upstream of the interceptor, being vented and installed according to manufacturers instructions and the currently published version of PDI G-101 Interceptor will be located within 25ft developed pipe run of the last connected appliance for operational compliance. Where applicable a secondary flow control will be employed in installations where there is greater than 8ft of vertical elevation between the kitchen discharge appliances and the interceptor inlet.

Capacities

XL75 XL100

Part Number Add Suffix "T" For FPT Connections	4075A04 4075A04T	40100A04 40100A04T
Flow Rate (GPM)	75	100
Flow Rate (L/Sec)	4.74	6.3
CAPACITY - Lbs (MIN)	150	200
CAPACITY - Kg (MIN)	68	91
MAX CAPACITY - Lbs (Kg) (Actual - NSF ES15741)	559lbs (253kg)	1058lbs (480kg)
Solids Capacity lbs (Kg) estimated	260lbs (118kg) 45 Gallons	350lbs (159kg) 60 Gallons

Average Efficiency %	=>98%	=>98%
Operating Temperature Capabilities (Intermittent discharge)	160°F (71°C)	160°F (71°C)
Cover Load Capacity (Third Party Tested)	> 20,000 lbs (9072 kgs)	> 20,000 lbs (9072 kgs)
Unit Weight (Empty)	233 lbs (106 kgs)	283 lbs (128 kgs)
Liquid Capacity	158 gal (598 L)	257 gal (973 L)
Connection size (mechanical joint)	4"	4"



For full CAD, BIM Models and 3 Part Master Format Specs visit www.arcata.com Search keyword "endura"

Endura® XL - INTERIOR OR EXTERIOR BELOW GRADE INSTALLATION INSTRUCTIONS

1. **EXCAVATION**
 - 1.1 Install the Endura® XL unit(s) as close as possible to fixtures being serviced, ideally within 25ft of developed pipe run from the last fixture to the inlet of the interceptor.
 - 1.2 Width and length of excavation shall be minimum 12" greater than the tank dimensions on all sides.
 - 1.3 Depth of excavation shall be at least 6" deeper than tank bottom.
 - 1.4 **IMPORTANT:** Maximum burial depth 6ft (72") measured from the air balance channel (EnduraXL Logo) to finished grade/floor level. Riser extensions available (40100AX35) - (see below).
 - 1.5 Set the tank on well-packed aggregate material approximately 3/4" size rock, pea gravel or sand. When setting Endura® XL units they must be level laterally and longitudinally.
 - 1.6 Endura® XL tanks are specifically designed to resist buoyancy in high water table conditions. Additional anchoring may however be necessary as determined by the specifying engineer. Tie-down locations are incorporated to the tank and can be used in conjunction with coated stainless steel cable and an applicable anchoring method based on subsoil. Specific requirements to be determined by specifying engineer.
2. **BACKFILLING & FINISHED CONCRETE SLAB (TRAFFIC LOAD RATED)**

Endura® XL is supplied standard with traffic rated covers designed in accordance with AASHTO 304 - H20 (16,000lbs) and approved to CSA B48.10 Class 5' 20" Ft to +100' F (-29° C to +38° C)

 - 2.1 Preparation of sub grade per local jurisdictional recommendations.
 - 2.2 Stabilize and compact sub grade to 95% proctor per Excavation information above.
 - 2.3 Fill tank with water (to discharge level) to prevent movement during backfilling process and to resist backfill load.
 - 2.4 Before backfilling and pouring of slab, install riser(s) (as necessary) and cover assembly to suit finished floor/grade level.
 - 2.5 Backfill using crushed aggregate material approximately 3/4" size rock, pea gravel or sand.
 - 2.6 Place minimum 6" aggregate base beneath poured structural slab. Aggregate should be 3/4" size rock or pea shingle.
 - 2.7 Thickness of concrete around cover to be determined by specifying engineer. If traffic loading is required refer to local specifying engineer recommendations and/or local code requirements. Note: Concrete slab dimensions shown are for illustration purposes only.
 - 2.8 Concrete to be 28 day compressive strength to 4000 PSI. Reinforcement with No. 4 rebar (1/2") grade 60 steel per ASTM A615; connected with tie wire. Rebar to be 2 1/2" from edge of concrete. Rebar spacing 12" grid, 4" spacing around access openings.
3. **PIPING CONNECTIONS**
 - 3.1 All Endura® XL Grease Interceptors are manufactured with no hub connections. Threaded connections are available from your Endura distributor affixing the product code with "T" - i.e. 40100M04T
 - 3.2 Locally approved mechanical joint (MJ) couplings are used to connect the inlet and outlet piping to the tank. This allows transition to different piping materials as required.
 - 3.3 Make system piping connections using locally approved MJ couplings installing to manufacturer's instructions. Review all field-made connections for leaks before backfilling begins. Isolate the tank from the system both up and down stream and fill tank with water, submerging the inlet and outlet fully below the water level. **DO NOT PRESSURE TEST - Risk of serious injury or death.**
 - 3.4 DO NOT decrease pipe diameter across the unit (i.e. 4 inch inlet, 3 inch outlet), if the piping system needs to be resized, use appropriate mechanical joint reducers consistent with the direction of flow and installed in compliance with local code.
4. **EXTENSION RISERS (Optional)**
 - 4.1 Endura® XL Extension Risers provide a maximum of 35" extension per riser. Based on maximum installation depth up to a maximum of 72" depth of burial can be achieved (see 1.4 above), adding Extension Risers (or part thereof) during installation. Risers are cut to length on site to suit installation.
 - 4.2 Remove cover from interceptor. Set aside for use at finished grade/floor level.
 - 4.3 Secure riser to tank (frame remains in place) using fixings provided. Ensure seal is correctly located.
 - 4.4 Secure the 1-1/2" adapter fitting supplied with the Extension Kit to the thread on the top of the handle mechanism. Cut and extend a length of 1 1/2" DWV pipe per instructions supplied.
 - 4.5 For custom riser length - measure from tank frame to finished grade/floor level. Subtract 1 1/2". Cut cleanly by hand or mechanical means using guide rings molded into the riser to give clean straight cut. Note - Horizontal surface of cover will be 0.5" above finished floor/grade.
 - 4.6 Fit riser seal provided over the cut edge of the riser and locate frame (supplied) over the seal making sure it is fully seated. Secure with bag screws provided using the pre-drilled locations in frame.
 - 4.7 Repeat process for additional riser fit as required.
 - 4.8 With frame installed and verified at the correct height, pass the handle extension support over the 1 1/2" DWV and secure the support to the frame with the screw provided. Solvent weld a 1 1/2" vent tee on top of the pipe to act as a handle.
 - 4.9 Re-fit the original cover(s) provided with the interceptor.

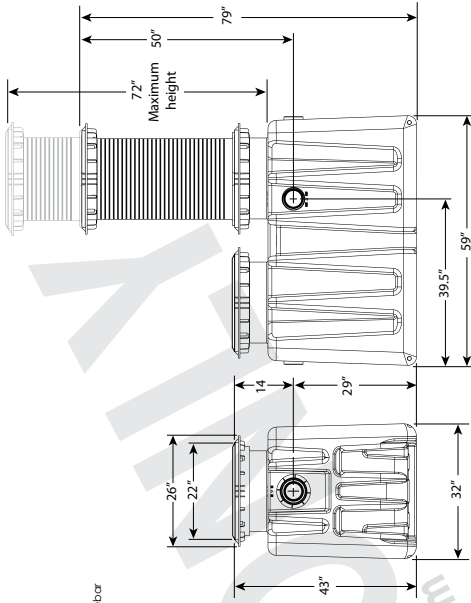

CONCRETE SLAB DETAIL FOR TRAFFIC LOADING (INTERIOR OR EXTERIOR)

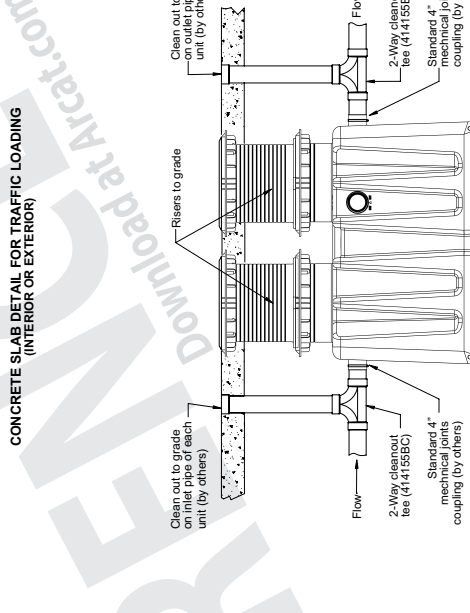

SIDE VIEW DETAIL
For unit details see specification sheet for selected unit (Connecting pipe and fittings by others)

EXCAVATION AND BACKFILL DETAIL (INTERIOR OR EXTERIOR)

NOTES:
Endura XL grease interceptors are rated and supplied with an internal flow control system already in place. They do not require an external flow control system or air intake vent unless specified by local code requirements or being installed as a PDI G-101 in installation. Endura XL grease interceptors are only to be installed in the manner and for the application shown. Consult local code for separate trapping requirements, cleanout locations and additional installation instructions. Full instructional information supplied with every interceptor.

PROPRIETARY AND CONFIDENTIAL - © Camplas 2015



ES15741
ASME A112.14.3 & CSA B481.1

Camplas Industries Ltd.
500 Veterans Drive, Box 1800
Barrie, Ontario,
Canada L4M 4V3
CAN: 1-800-461-1771 USA: 1-888-461-5307

Endura brand products manufactured by Camplas Industries.

DESCRIPTION:	
Endura XL 75 GPM	4075A04T
Grease Interceptor 4075A04	4075A04T
DWG NUMBER: 001	MATL: PE
DWG BY: L.S.	DATE: JAN, 2016
	REV: 1.1

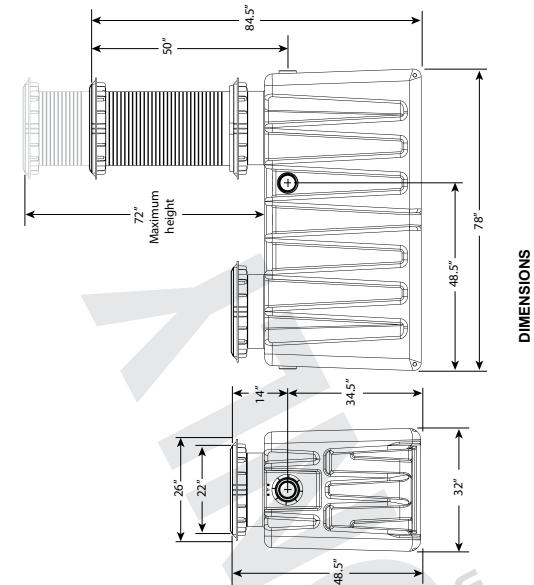

DIMENSIONS

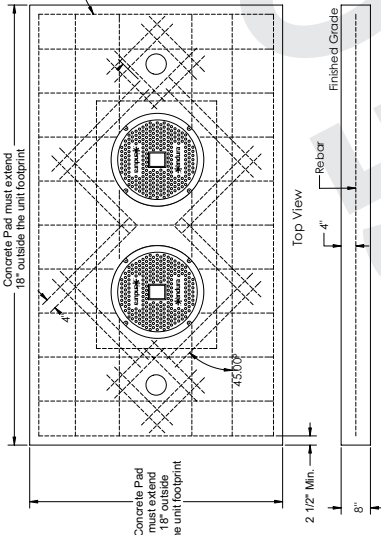

CONCRETE SLAB DETAIL FOR TRAFFIC LOADING (INTERIOR OR EXTERIOR)

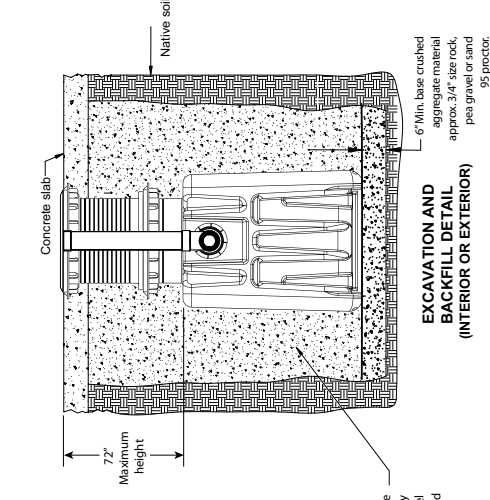

EXCAVATION AND BACKFILL DETAIL (INTERIOR OR EXTERIOR)

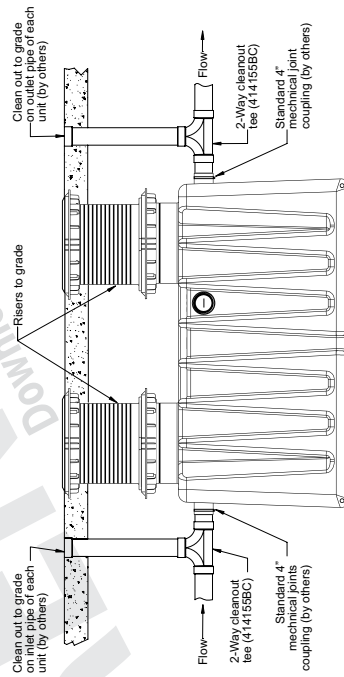

SIDE VIEW DETAIL

For unit details see specification sheet for selected unit (Connecting pipe and fittings by others)

NOTES:

Endura XL grease interceptors are rated and supplied with an internal flow control system already in place. They do not require an external flow control system or air intake vent unless specified by local code requirements or being operated as a PDI G-101 installation. Endura XL grease interceptors are only to be installed in the manner and for the application shown. Consult local codes for separate trapping requirements, cleanout locations and additional installation instructions. Full instructional information supplied with every interceptor.

PROPRIETARY AND CONFIDENTIAL - © Canplas 2016



DESCRIPTION: 	
DWG NUMBER: 002	DATE: JAN, 2016
DWG BY: L.S.	REV: 1.1
Canplas Industries Ltd. 500 Veterans Drive, Box 1800 Barrie, Ontario, Canada L4M 4V3 CAN: 1-800-461-1771 USA: 1-888-461-5307	

Endura® XL - INTERIOR OR EXTERIOR BELOW GRADE INSTALLATION INSTRUCTIONS

1. **EXCAVATION**
 - 1.1 Install the Endura® XL unit(s) as close as possible to fixtures being serviced, ideally within 25ft of developed pipe run from the last fixture to the inlet of the interceptor.
 - 1.2 Width and length of excavation shall be minimum 12" greater than the tank dimensions on all sides.
 - 1.3 Depth of excavation shall be at least 6" deeper than tank bottom.
 - 1.4 **IMPORTANT:** Maximum burial depth 6ft (72") measured from the air balance channel (EnduraXL Logo) to finished grade/floor level. Riser extensions available (40100A035) - (see below).
 - 1.5 Set the tank on well-packed crushed aggregate material approximately 3/4" size rock, pea gravel or sand. When setting Endura® XL units they must be level laterally and longitudinally.
 - 1.6 Endura® XL tanks are specifically designed to resist buoyancy in high water table conditions. Additional anchoring may however be necessary as determined by the specifying engineer. Tie-down locations are incorporated to the tank and can be used in conjunction with coated stainless steel cable and an applicable anchoring method based on subsoil. Specific requirements to be determined by specifying engineer.
2. **BACKFILLING & FINISHED CONCRETE SLAB (TRAFFIC LOAD RATED)**
 - 2.1 Endura® XL is supplied standard with traffic rated covers designed in accordance with AASHTO 304 - H20 (16,000lbs) and approved to CSA B481.0 Class S-20° F to +100° F (-29° C to +38° C).
 - 2.2 Stabilize and compact sub grade to 95% proctor, per Excavation information above.
 - 2.3 Fill tank with water (to discharge level) to prevent movement during backfilling process and to resist backfill load.
 - 2.4 Before backfilling and pouring of slab, install riser(s) (as necessary) and cover assembly to suit finished floor/grade level.
 - 2.5 Backfill using crushed aggregate material approximately 3/4" size rock, pea gravel or sand.
 - 2.6 Place minimum 6" aggregate base beneath structural slab. Aggregate should be 3/4" size rock or pea shingle.
 - 2.7 Thickness of concrete around cover to be determined by specifying engineer. If traffic loading is required refer to local specifying engineer recommendations and/or local code requirements. Note: Concrete slab dimensions shown are for illustration purposes only.
 - 2.8 Concrete to be 28 day compressive strength to 4000 PSI. Reinforcement with No.4 rebar (1/2") grade 60 steel per ASTM A615, connected with tie wire. Rebar to be 2 1/2" from edge of concrete. Rebar spacing 12" grid, 4" spacing around access openings.

3. PIPING CONNECTIONS

- 3.1 All Endura® XL Grease Interceptors are manufactured with no hub connections. Threaded connections are available from your Endura distributor affixing the product code with "T" - i.e. 40100A04T
- 3.2 Locally approved mechanical joint (MJ) couplings are used to connect the inlet and outlet piping to the tank. This allows transition to different piping materials as required.
- 3.3 Make system piping connections using locally approved MJ couplings installing to manufacturer's instructions. Review all field-made connections for leaks before backfilling begins. Isolate the tank from the system both up and down stream and fill tank with water, submerging the inlet and outlet fully below the water level. **DO NOT PRESSURE TEST - Risk of serious Injury or Death.**
- 3.4 DO NOT decrease pipe diameter across the unit (i.e. 4 inch inlet, 3 inch outlet). If the piping system needs to be resized, use appropriate mechanical joint reducers consistent with the direction of flow and installed in compliance with local code.

4. EXTENSION RISERS (Optional)

- 4.1 Endura® XL Extension Risers provide a maximum of 35" extension per riser. Based on maximum installation depth up to a maximum of 72" depth of burial can achieved (see 1.4 above), adding Extension Risers (or part thereof) during installation. Risers are cut to length on site to suit installation.
- 4.2 Remove cover from interceptor. Set aside for use at finished grade/floor level.
- 4.3 Secure riser to tank (frame remains in place) using fixings provided. Ensure seal is correctly located.
- 4.4 Secure the 1-1/2" adapter fitting supplied with the Extension Kit to the thread on the top of the handle mechanism. Cut and extend a length of 1/2" DWV pipe per instructions supplied.
- 4.5 For custom riser length - measure from tank frame to finished grade/floor level. Subtract 1 1/2" Cut cleanly by hand or mechanical means using guide rings molded into the riser to give clean straight cut. Note - Horizontal surface of cover will be 0.5" above finished floor/grade.
- 4.6 Fit riser seal provided over the cut edge of the riser and locate frame (supplied) over the seal making sure it is fully seated. Secure with bag screws provided using the pre-drilled locations in frame.
- 4.7 Repeat process for additional riser fit as required.
- 4.8 With frame installed and verified at the correct height, pass the handle extension support over the 1 1/2" DWV and secure the support to the frame with the screw provided. Solvent weld a 1 1/2" vent tee on top of the pipe to act as a handle.
- 4.9 Re-fit the original cover(s) provided with the interceptor.

2 no. XL75 – SERIES – 75GPM, 1118 lbs Grease Capacity.



External Flow Control If Required

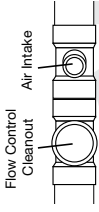

Where preferred or required an external flow control (purchased separately) will be installed upstream after last branch connection no further than 25ft from interceptor

2 no. XL100 – SERIES – 100GPM, 2116 lbs Grease Capacity.



3 no. XL100 – SERIES – 100GPM, 3174 lbs Grease Capacity.

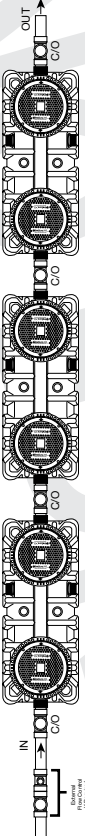

4 no. XL100 – SERIES – Up to 400GPM, 4232 lbs Grease Capacity.



Series Installation:

- Series configurations shown are considered optimal for application and should be followed
- Anticipated as installations with low to medium flow (less than 60% of rated flow capacity)
- Where preferred or required, installation of a correctly rated external flow control shall be made upstream and with reference to PDI G101 where applicable. A single flow control shall be located upstream of any flow division and vented accordingly. Location shall be accessible once operational.
- Important:** Internal flow control plates are to be removed in this operational format.
- Adequate provision for drain access is essential. Two way cleanouts extended to grade are required before the first tank inlet and following the final outlet. Access between tanks is also recommended if pipe length is greater than 36"
- Connections to tank made with approved Mechanical Joint (MJ) couplings or male pipe thread dependent on unit specification.
- Manufacturer's instructions supplied with units must be followed.

4 no. XL100 – SERIES – Up to 400GPM, 4232 lbs Grease Capacity.

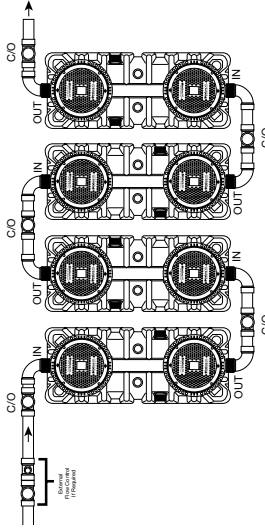

Recommended Components:

Canplas Part#	Description	QTY
414155BC	SDR35 Two Way Cleanout - HxHxH	
414174BC	SDR35 90° Bend - Street - HxSpG	
414130BC	SDR35 Double Wye - HxHxHxH	
414226BC	SDR 35 6 x 4 Ext. Reducer HxSpG	
414194BC	SDR 35 45° Bend - Street	
4044275	Endura® XL 75gpm Flow Control	
40442100	Endura® XL 100gpm Flow Control	

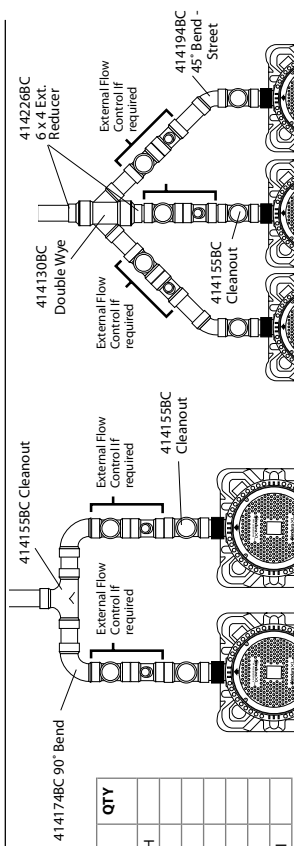

3 no. XL100 – PARALLEL Up to 300GPM, 3174 lbs Grease Capacity.

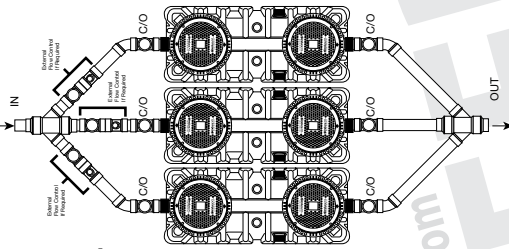

2 no. XL100 – PARALLEL Up to 200GPM, 2116 lbs Grease Capacity.

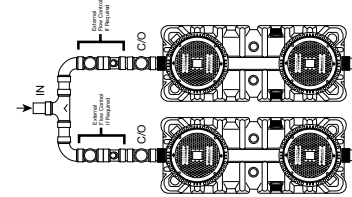

2 no. XL75 – PARALLEL Up to 150GPM, 1118 lbs Grease Capacity.

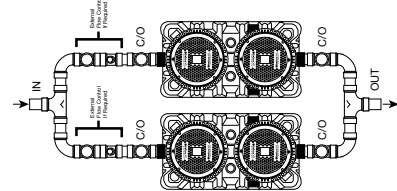

4 no. XL100 – PARALLEL Up to 400GPM, 4232 lbs Grease Capacity.

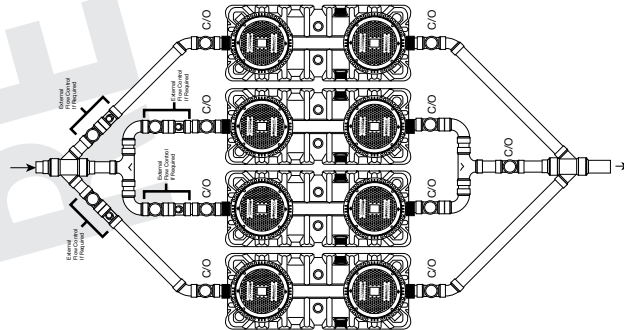

Parallel Installation:

- Parallel configurations shown are considered optimal for application and should be followed.
- Intended for installations with high flow (greater than 60% of rated flow capacity) per unit.
- Where External Flow Control is not required or preferred, the parallel configuration can be operated with internal flow controls managing flow to the respective interceptor
- Where preferred or required, installation of a correctly rated external flow control shall be made upstream of the interceptor inlet but downstream of any division of flow. Flow control shall be accessible (from grade as applicable) once operational.
- Adequate provision for drain access is essential. Two way cleanouts extended to grade are required before all tank inlets and following all outlets. Access between tanks is also recommended if pipe length is greater than 36"
- Connections to tank made with approved Mechanical Joint (MJ) couplings or male pipe thread dependent on unit specification.
- Manufacturer's instructions supplied with units must be followed.

NOTES:

Endura XL grease interceptors are rated and supplied with an internal flow control system already in place. They do not require an external flow control system or air intake vent unless specified by local code requirements or being operated as a PDI G-101 installation. Endura XL grease interceptors are only to be installed in the manner and for the application shown. Consult local codes for separate trapping requirements, cleanout locations and additional installation instructions. Full instructional information supplied with every interceptor.

DESCRIPTION: **Endura XL**

Grease Interceptor 4075A04 4075A04T
 40100A04 40100A04T

DWG NUMBER: 003 MATL: PE

DWG BY: L.S. DATE: JAN, 2016 REV: 1.1

Canplas Industries Ltd.
 500 Veterans Drive, Box 1800
 Barrie, Ontario,
 Canada L4M 4V3

Endura brand products
 manufactured by
 Canplas Industries.

CAN: 1-800-461-1771 USA: 1-888-461-5307

Installation

SAFETY FIRST! All installation shall be conducted under the applicable Health and Safety regulations in force within that jurisdiction. Plumbing operatives shall be adequately trained and appropriately licensed to conduct the installation. All installations will be made respective and in compliance with applicable plumbing code and any locally published by-laws. Installation and approval of the same is subject to the appropriate officials or representatives of the Authority Having Jurisdiction (AHJ).

Scope of Application:

Endura® XL Grease Interceptors are designed for application in the efficient and effective separation and retention of non-petroleum Fats, Oil and Grease as a by-product of commercial foodservice activities. The Endura® XL interceptor models are approved and intended only for use in the specified application and shall not be installed in any manor or application except as tested and rated.

Accessibility:

Installations shall be made in such a manner that full access for maintenance and cleaning is maintained once the interceptor is commissioned. A zone based on a column measured 3ft out from the cover perimeter and extending 7ft vertically is recommended.

Inlet (IN) and Outlet (OUT) connections are indicated on the interceptor itself. Ensure that the interceptor is in the correct orientation and flow in the intended direction before backfilling (when in ground) or connection to the respective drain system.

Location:

A grease interceptor should be installed as close as possible to the fixtures it serves to avoid accumulation of FOG between the source and the interceptor. Adequate provision for rodding and service access is particularly important upstream of the interceptor. Please refer to local code requirements.

Drain lines servicing the interceptor shall be laid at a minimum ¼" per foot fall and with more gradient where possible. This promotes good drainage flow and reduces risk of blockages.

Piping Connections:

The primary bulkhead-style connections (in-line) of Endura® XL are injection molded in Polypropylene (PP). PP does not accept solvent weld cement and will not provide a serviceable connection. DO NOT SOLVENT WELD these drain connections.

Best practice and most codes typically require the use of Nationally or locally approved Mechanical Joint (MJ) couplings for the connections to and from the interceptor. This method provides some flexibility for any ground movement or settling that may occur.

Flow Control:

Where required or preferred an External Flow control can be installed. In this configuration the installation has the opportunity to meet the requirements of PDI G-101, assuming that the applicable venting and installation criteria are met (See Page 12). Refer to the currently published version of PDI G-101 available online at www.pdionline.org for verification.

Trapping:

All connected appliances and fixtures must be individually trapped by a permanently installed water seal trap or approved equivalent, in compliance with applicable plumbing code requirements.

Venting:

The installation of the interceptor shall be vented downstream in accordance with local code requirements.

Indirect Connections/ Air Gap/Air Brake :

Some local jurisdictions require warewashing installations to be made on an indirect basis incorporating an air gap.

This is to prevent the back up of contaminated waste water into the sinks/appliances in the event of a blockage. As the flow control device provides a restriction within the system it must be incorporated before the indirect connection to prevent the risk of overflow occurring during high/maximum waste water discharge. If an air gap/air break* is located within 6" of flow control device, installation of the air intake tee is optimal.

*Dependent on jurisdiction

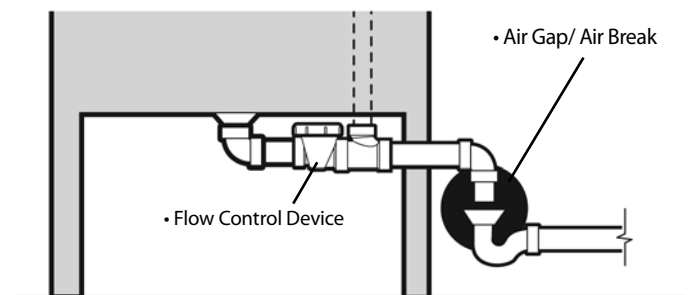

Flow Controls

Depending on preference or requirement Endura® XL can be operated with an internal or external flow control. All models are supplied with an internal flow control.

Internal Flow Control:

The internal flow control is located inside the dynamic inlet baffle, affixed to the downstream part that moves forward when the baffle is opened.



The flow control is an essential part of the hydromechanical grease interceptor and its function.

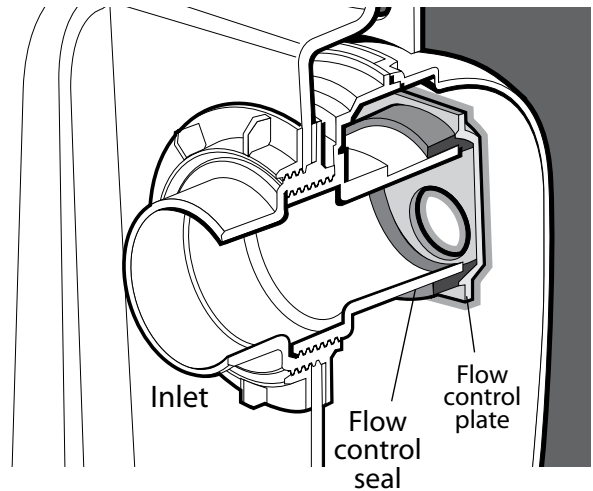

External Flow Control:

With the internal flow control plate removed, the flow control function will now be performed by a separate device that will be installed upstream from the interceptor. This is located as close as possible to the appliances and fixtures being served, but after the last branch connection to the main drain line connected to the interceptor. The flow control shall be installed so as to remain accessible for maintenance and will typically be recessed into the floor. The location of the cleanout should be recorded in you Installer Hand Over Check List (See Page 14)

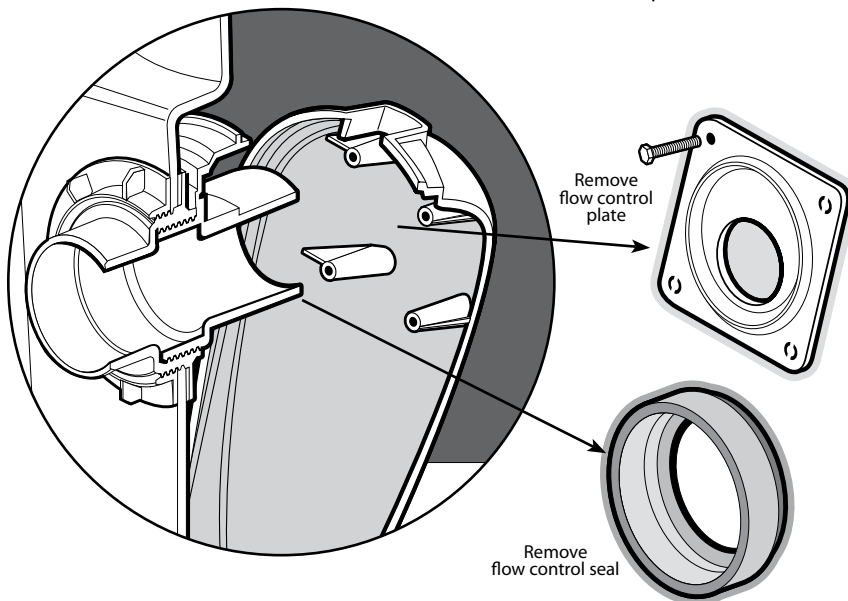
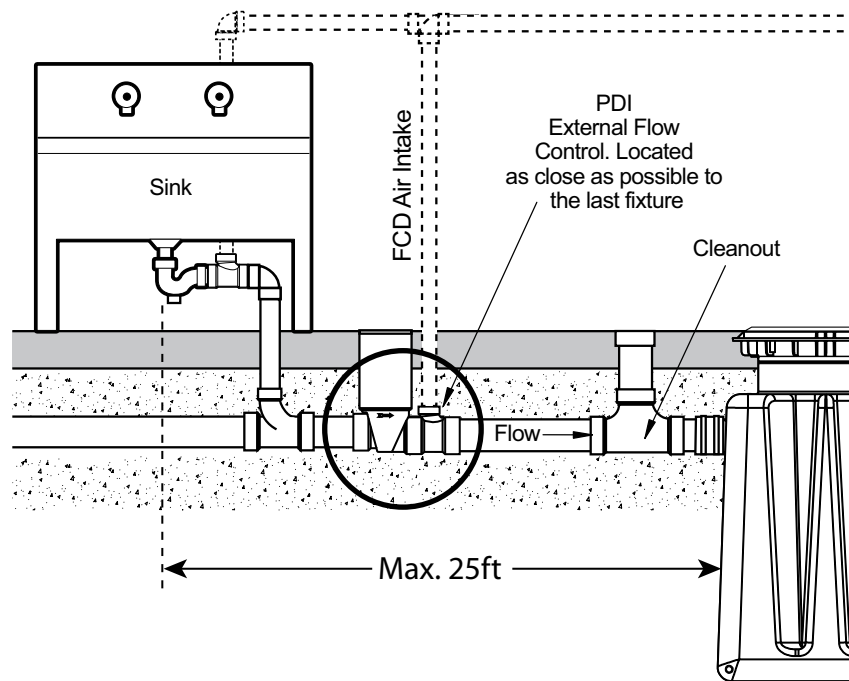

When installed with an External Flow Control, the internal flow control plate and seal shown above are removed during installation.

With an external flow control in particular, it is important that it be opened and checked periodically (min. twice annually) to ensure there is no build up or blockage occurring that will restrict the flow.

Remote Pump (Optional):

Endura® XL incorporates a method for installation of a Remote Pump function where desirable or required. The simplicity of this change is such that it can be conducted in the field with minimal materials. The installation is based on the use of a 3" DWV Sch40 pipe which is passed into the tank by means of a 3" diameter tank penetration seal (Part# 40100-TPS3").

1. Cut the end of a 3" Sch40 DWV pipe (ABS or PVC by preference) at an angle that is no less than 45 degrees.
2. **GOOD PREPARATION OF THIS PIPE END IS ESSENTIAL TO AVOID DAMAGING THE RUBBER SEAL WHEN BEING INSTALLED.** The outer edges must be chamfered to at least 45 degrees around the full length of the pipe end.
3. Now measure from the end of the pipe to the following length depending if you are installing an XL75 or XL100 respectively. For XL75 pipe length 36"; For XL100 pipe length 44" (Fig A)
4. On the top surface of the tank at the center position and on either side of the air balance channel are two "Remote Pump Ready" details, both of which include a drill center (Fig. B). Select which of the two locations best suits your application and using a 4" diameter hole saw, open the respective hole.
5. Fit penetration tank seal (Part# 40100-TPS) into the opening prepared and lubricate well using silicone pipe lubricant.
6. As the orientation of the pipe when installed is important, mark or identify on the top of the pipe so as to indicate that the angled face of the pipe will be facing laterally across the interceptor when installed. i.e. the angled face is pointed toward the opposite tank wall.
7. Take your prepared length of pipe and liberally apply silicone pipe lubricant to at least the first 6" of the pipe ensuring that the angled surface is also well lubricated.
8. Introduce the pipe to the rubber seal and with even pressure and a rotating motion, push the pipe through the seal and into the tank. Once onto the full diameter of the pipe apply more lubricant to the next 12-18" and continue to push the pipe downward into the tank until the tip bottoms out, with the angled face in the correct position.
9. Develop your pump out line connecting to the pipe stub now extending from the tank using long sweep bends and fittings and making provision for adequate cleanout access as required. All joints must be solvent welded or of threaded format. Maximum developed pipe run shall be no greater than 30 feet with a vertical rise of 8 feet max.
10. At the extent of the remote pump system where the pumping service will be connected, typically a capped male camlock fitting (3") will be provided to allow compatibility with vacuum service connection.

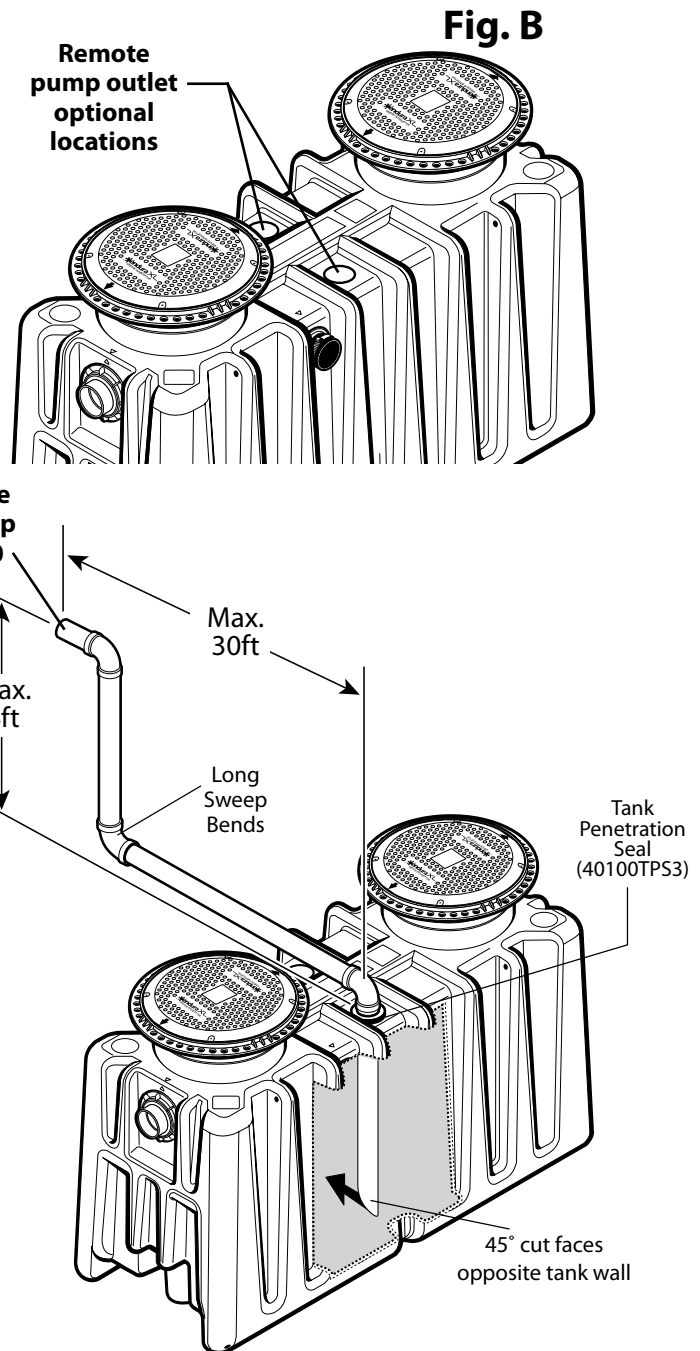
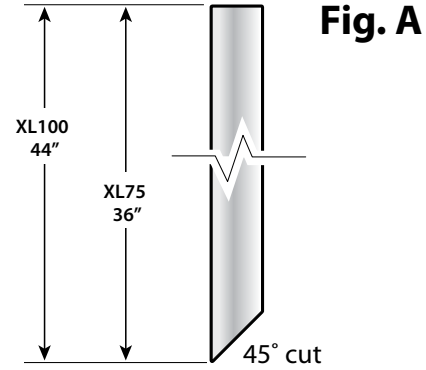

Installer Handover Checklist

The following checklist completed by your installer provides key information regarding your XL grease interceptor and the way it has been installed. If it is not completed contact your installer and complete with them by phone or other appropriate means.

Installation made by (Company) _____

Installer (Name) _____

Installer Contact (Tel) _____

Completed on (Date) _____

Model Installed: Endura® XL100 (40100A04 (T) / 100GPM)

Endura® XL75 (4075A04 (T) / 75GPM)

Installation Format: On-Floor In Floor - Inside Building Floor Below (eg. basement)

In-Ground - Outside building

Slab Poured per Spec for Traffic Rated Install Yes No (See Page 8-9)

Flow Control Format: Internal (Inside Inlet Baffle)

External (Upstream of Interceptor)

If External Flow Control...

Internal Flow Control plate removed Yes No (See Page 12)

Flow Control Location(s) _____

Connections & Cleanouts (Mark where installed):

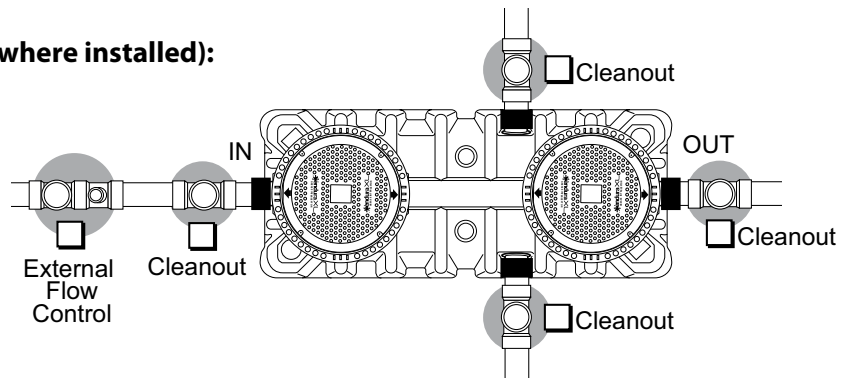

Extension Risers added: Yes - if Yes, approx. length of riser installed: _____ in /m
 No

Flow Control Handle Extended: Yes No (See Riser Extension Instructions)

Air Balance/Sampling Cap in place: Yes No (If No, Replacement required. See Page 16)

Entered Information on Warranty Page Yes No

Have feedback?

Email us at... feedback@endurainterceptor.com

Operation

SAFETY FIRST! Ensure that any operatives or employees that attend to the grease interceptor are adequately protected. As a minimum it is recommended that protective gloves, eyewear and a mask are provided and used.



Accessibility:

It is the responsibility of the restaurant operator to maintain safe, clear and unobstructed access to the interceptor at all times. This facilitates inspection by local officials, emergency access in the event of an issue and for the regular pumping of the interceptor required to keep it in good working order.

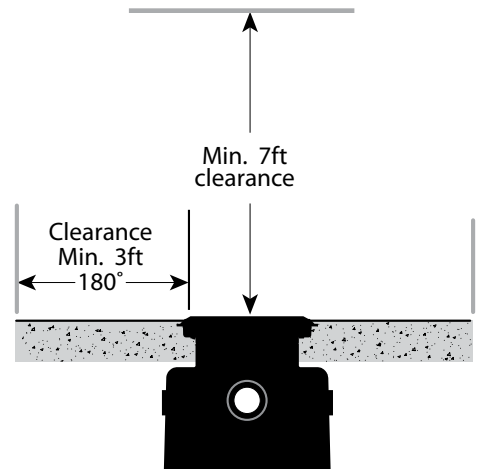

IMPORTANT: The key to effective and trouble free operation of your Endura® XL interceptor is regular and effective maintenance. You should consider your facility to be in partnership with the local authorities, providing an effective means of FOG management that is mandated to protect your business, your community and the environment.

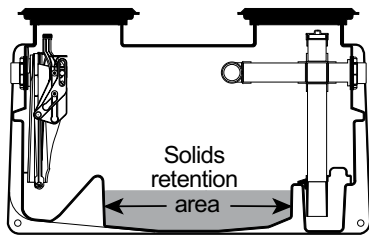

Food Solids and Debris:

Endura® XL is designed to manage up to 15% of its volume for solids management. Remember however that your grease interceptor is an engineered system that is not designed to accommodate large amounts of solid material. This will impact the operational capacity and performance of the unit and cause the foul odors often associated with grease interceptors if not removed regularly.

It is strongly recommended that a solids interceptor be installed upstream of the grease interceptor and that all entry points to the drains running to the interceptor be adequately protected with appropriate screens to prevent debris finding its way into the system. Likewise, best kitchen practice recommends that all plates, crockery, pans, etc., be scraped to remove loose food debris prior to washing. Again sinks should be operated with the respective screens.

If you are experiencing frequent issues in regard to blockages or accumulation in your interceptor you must address the appropriate kitchen practices. **DO NOT MODIFY THE INTERCEPTOR OR MEANS OF FLOW CONTROL IN ANY MANNER.** Doing so voids the performance approval required by your local jurisdiction and will leave your operation exposed to the risk of significant fines and non-compliance citations.

Dynamic Inlet Baffle:

The Inlet baffle design in your Endura® XL Interceptor is uniquely accessible once in service. Having removed the cover above the inlet, a simple pull/push motion on the handle opens and closes the front shell, allowing access for maintenance and cleaning. This action also opens the inlet drain to its full diameter allowing the upstream drains to be cleaned without obstruction.

This baffle can be extended to maintain its function and value even when buried at full depth below grade. Refer to installation instructions for riser extension.

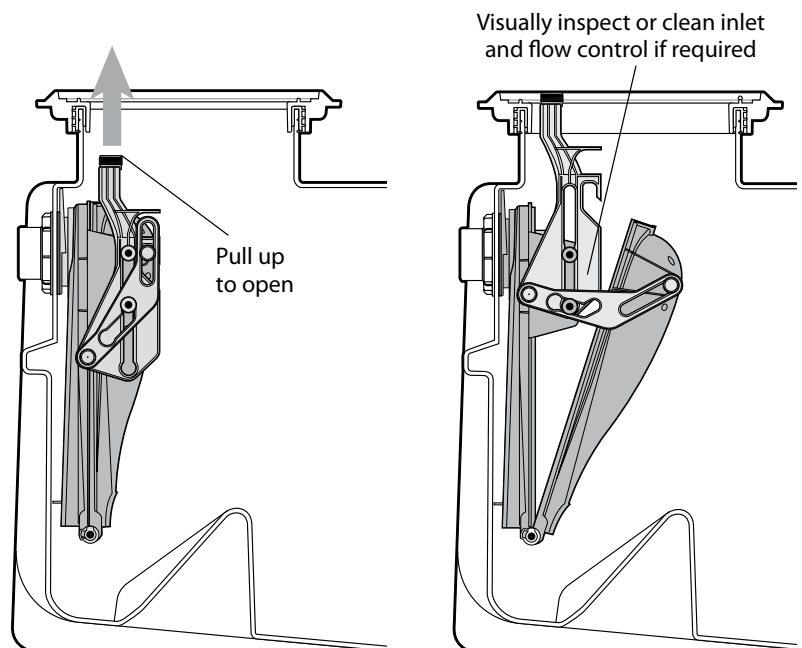

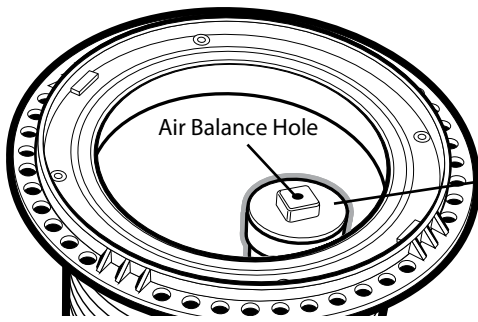

**Air Balance/
Sampling Cap is
ESSENTIAL to the
operation of the
interceptor and
must be kept free
of debris.**

**If extending height,
sampling/air balance
cap must be raised also.**

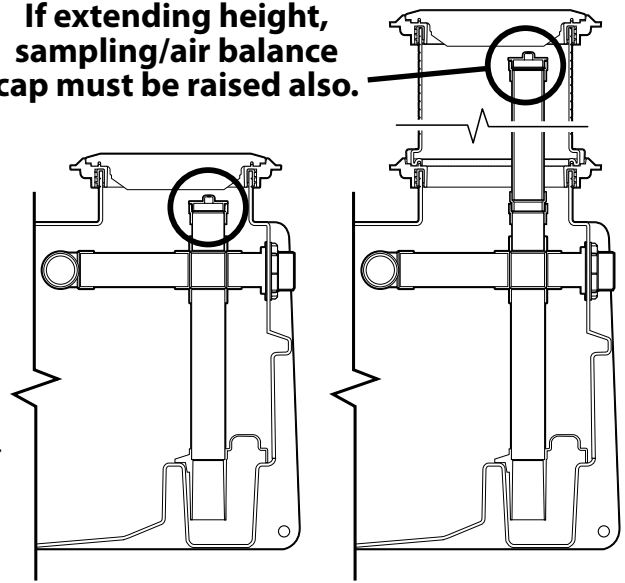

**IF YOU DO NOT SEE A GREY CAP ON TOP
OF THE OUTLET SYSTEM, CONTACT YOUR
INSTALLER/MAINTENANCE CONTRACTOR
IMMEDIATELY AND IF NECESSARY
PURCHASE A REPLACEMENT.**

Air Balanced Operation:

Endura® XL is designed to function based on a balance air environment. This feature ensures that the high operating efficiency is maintained. During the maintenance of your interceptor, it is important to check that the breather hole in the outlet vent (see diagram) is unobstructed. The smallest restriction can drastically impact the performance of your interceptor and can cause the accumulated contents of the interceptor to be discharged to the downstream drain system particularly if discharge rates are toward the maximum rated flow.

If installed in-floor or in ground outside your facility this air balance access/breather cap must be relocated upward as close as possible to the underside of the cover to maintain its function.

Maintenance



IMPORTANT: The key to effective and trouble free operation of your Endura® XL interceptor is regular and effective maintenance. You should consider your facility to be in partnership with the local authorities, providing an effective means of FOG management that is mandated to protect your business, your community and the environment.



Regular Removal of Fat, Oil and Grease:

Due to the capacity of your Endura® XL Grease Interceptor it is necessary to have a licensed and locally approved service provider manage the regular removal, cleaning and disposal of the Fats, Oil and Grease that is captured in your interceptor.

Every installation is different based on factors such as operational hours, menu, seasonality of business, staff changes, etc. As a rule of thumb your interceptor should be cleaned every 8-12 weeks. You should anticipate a minimum of 4-6 cleans per year.

SAFETY FIRST! ALL ACCESS COVERS SHALL BE FULLY AND COMPLETELY SECURED (all bolts in place and tightened accordingly) at the completion of maintenance procedures, regardless of if the cover was accessed or not. Missing bolts shall be reported to management and replaced immediately.

Ensure that any operatives or employees that attend to the grease interceptor are adequately protected. As a minimum it is recommended that protective gloves, eyewear and a mask are provided and used.

Where a third party contractor or service is responsible for the regular maintenance of the interceptor (strongly recommended) it is their responsibility not only to ensure that their own protective practices and procedures are maintained and followed, but that they also protect those with access to the vicinity of the interceptor when it is

undergoing maintenance. In addition they will be stewards of the environment, promptly and effectively identifying to premises management issues with for example, but not limited to, interceptor operation, damages, spills, etc.

IMPORTANT: The key to effective and trouble free operation of your Endura® XL interceptor is regular and effective maintenance (See Maintenance Procedures – Pg 17). You should consider your facility to be in partnership with the local authorities, providing an effective means of FOG management that is mandated to protect your business, your community and the environment.

Regular Removal of Fat, Oil and Grease:

Due to the capacity of your Endura® XL Grease Interceptor it is necessary to have a licensed and locally approved service provider manage the regular removal, cleaning and disposal of the Fats, Oil and Grease that is captured in your interceptor.

Maintenance Procedures:



Remember: Every installation is different based on factors such as operational hours, menu, seasonality of business, staff changes, etc. As a rule of thumb your interceptor should be cleaned every 8-12 weeks. You should anticipate a minimum of 4 cleans per year.

Removal of Access Cover:

The covers that provide access to the XL interceptors are retained with four (4) standard hex head bolts which are removed with a 1/2" socket/driver. These bolts have a retraining washer on the reverse to prevent them falling out of their location when the cover is removed from the interceptor.

Covers incorporate pry points for ease of removal. Each cover weighs approximately 22lbs (10kg) so take care when lifting and moving the cover. Always set aside the cover on a flat surface when removed. On reinstallation visually check the seal recessed in the underside of the cover and when satisfied refit the cover being sure not to overtighten the bolts. Maximum torque is 80-100 ft/lb.

Access to the Dynamic Inlet Baffle (Internal Flow Control where used):

The Dynamic Inlet Baffle is a unique element of Endura® XL allowing access to the internal surfaces for maintenance, inspection and cleaning.

To open the baffle, take a firm grip on the handle and pull vertically upward. The handle will move approximately 6" in the vertical direction. In doing so the front shell of the baffle moves away from the fixed rear portion providing access to the internal flow control plate (where fitted).

The flow control plate is securely retained but is intended to be removable during installation, should an external flow control be the preferred format of installation.

Once open, visual inspection can be made inside the baffle. Any debris is best removed with a low pressure source of warm water – approx. 38°C (100°F)

To close the baffle, push vertically downward on the handle until it returns to the full closed and locked position

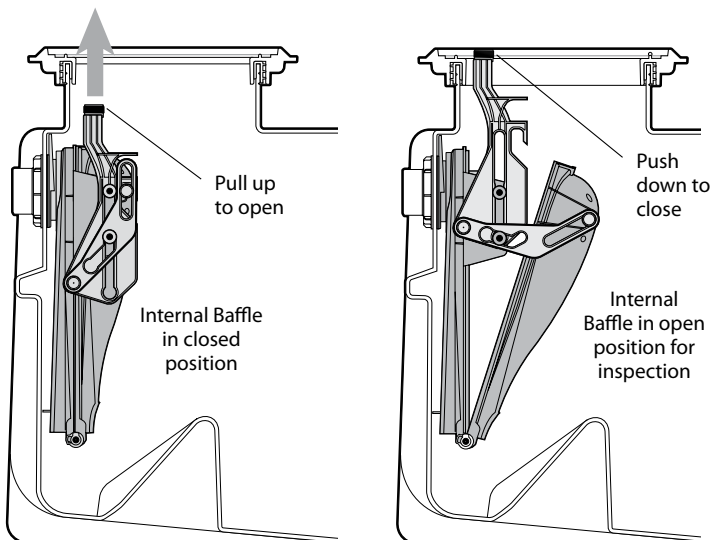

Drain Cleaning/Inspection:

For cleaning and inspection of the upstream drain, it is strongly recommended that the inlet baffle be in the open position. This will reduce the risk of damage to the internal flow control (where fitted) by rooting or other equipment.

Access to the Outlet Well:

Although essentially a closed area, the outlet system is able to be accessed by removal of the Sampling/Air Balance Cap. Once removed the 4" vertical pipe is able to be visually inspected all the way to the bottom (with the unit pumped out), and in the event of any accumulation can be cleaned by vacuum or pressurized water, either withdrawing debris out or back into the tank respectively.

Pumping and Cleaning:

The complete removal of grease and water should be done at every pump out. This ensures all solids, grease and water are removed allowing visual inspection and removal of any residue.

Any residue is best removed with a hot water source rinsing the walls and internal components into the tank before making a final vacuum extraction.



The tank must be re-filled to static water level on completion of pumping. An interceptor cannot function without water.

Remote Pump Out (Optional):

An installation fitted with the remote pumping option offers convenience for the pumper and the restaurant operator, but also presents risk.

Where installed and operated with a remote pump facility, the interceptor should be physically opened and inspected at least every third pumping, or twice a year, whichever is sooner. This is to ensure that the internal parts are in good working order and that there is no undue build-up of residue or solids remaining in the tank once it has been emptied. This also presents opportunity to open and inspect the inside of the inlet baffle system, and clean/inspect the outlet well. Any residue will be removed with a warm water source.

Pumper Checklist:

Interceptor Operating at: _____ (Enter Facility Name)

Address: _____

Serviced By (Name): _____

Company: _____

Company Contact (Tel): _____

About this Pump-Out:

Service Date: _____

Format: Remote Pump Full Access (Covers Removed)

Last Full Access Pump? _____

Note: At a minimum of every 3rd remote pump or twice annually (whichever is sooner) full access cleaning and inspection is required.

Interceptor Fully Pumped (Water/FOG & Solids): Yes No

Approx. Volume of Waste Removed: _____ Gallons/Liters

Inlet Baffle Opened/Inspected Yes No

Flow Control Checked/Cleaned Yes No

Note: The flow control device (internal or external), shall be inspected and cleaned a minimum of every 3rd pump or twice annually (whichever is sooner)

Cover(s) secured on completion of Pumping? Yes No

Important Note: If covers are in an area that is accessible to the public, always check to ensure that covers are fully secured even if you did not remove the cover(s) as part of this pump-out.

Any Concerns, Issues or Comments to Report: _____

Have feedback?
Email us at... feedback@endurainterceptor.com

Need Technical Support?

Canada

U.S.A.

1-800-461-1771

1-888-461-5307

Email: tech-support@endurainterceptor.com

Trouble Shooting

Troubleshooting		
Symptoms	Cause	Corrective Actions
Strong pungent odour.	• Cover not replaced and/or properly secured	• Secure cover fully - check that there is no dirt/debris in the threaded insert
	• Cover seal missing or damaged	• Replace appropriate seal
	• Insufficient or incorrect venting	• Verify installation is made per manufacturer's instructions and local plumbing code
	• Insufficient cleaning frequency	• Reduce interval between cleaning – 6 to 8 weeks is typical for extended capacity, but each installation is different
Sink or drain has backed up with water	• Interceptor maintenance is overdue	• The grease trap close to, at or beyond its capacity of solids and/or grease
	• Accumulation of grease/debris between kitchen and interceptor	• Seek emergency plumbing assistance to remove restriction/blockage. Consider moving the interceptor closer to the kitchen
	• The flow control orifice is blocked	• Isolate drain, open accessible flow control and clear blockage
	• The flow control and grease trap was improperly sized	• Close the ball valve or plug the sink and remove the obstruction by removing the flow control access lid. • Install a properly sized grease interceptor
	• The grease trap is full of solids and/or grease	• Increase cleaning frequency
I think I have missing parts	• Parts have been removed or lost during prior servicing	• Check exploded drawing in this manual to confirm the parts that are supposed to make up your interceptor model
Excessive solids / grease accumulation	• The Grease Interceptor is full/requires cleaning	• Increase cleaning frequency
	• Food waste on pots, plates & utensils are not being scraped into the garbage & is being flushed down the sink. This food waste accumulates on the bottom of the tank	• Train staff as to importance of good kitchen practices • Install a solids interceptor in or upstream of the interceptor. Use screens on floor drains and sinks
	• Grease interceptor has remained dormant for a period of time	• Contact a licensed service professional to re-commission your interceptor
My indirect connection leaks all over the floor when I empty the sink(s)	• Incorrectly installed/located flow control device	• Move flow control device to a location upstream of the indirect connection
The XL inlet baffle is not working/is broken	• Damaged/broken parts	• For technical assistance email tech-support@endurainterceptor.com mark your email - High priority

Frequently Asked Questions

Following are just a few of the common terms and questions we receive regarding Grease Management.

How do I size a Grease Interceptor correctly?

A grease interceptor can be sized using two primary methods - Flow rate or capacity

Flow Rate – When sizing by Flow Rate there are two options

Fixture Capacity: Most commonly used and recommended method for Hydromechanical Grease Interceptors. This method looks at the maximum capacity of fixtures connected to the interceptor and the time taken to discharge that volume of wastewater through the interceptor. Units are expressed in Gallons Per Minute (gpm).

Calculation takes 75% of maximum capacity of all fixtures and based on a 1 or 2 minute period of time taken to discharge, results in a gallons per minute flow rate. This number is rounded up to the next available size of interceptor, i.e. 16.7gpm become a 20gpm Grease Interceptor.

Pipe Size:

Pipe Diameter	Maximum Flow Rate (gpm)	Size of interceptor 1-minute drain period (gpm)	Size of interceptor 2-minute drain period (gpm)
2-inch	20	20	10
3-inch	60	75	35
4-inch	125	150	75

Capacity: Based on the volume of wastewater discharge (gallons) into the interceptor expressed as discharge fixture units (DFU's). DFU's are identified in the currently published issue of Uniform Plumbing Code Ch.7 based on occupancy or use.

Fixture	Fixture Units Public
Floor drain, non-emergency	2
Special purpose sink w/1-1/2" trap	3
Special purpose sink w/2" trap	4
Special purpose sink w/3" trap	6
Commercial sink w/food waste w/ 1-1/2" trap	3
Bar Sink	2
Mop Sink	3
Laundry Sink	2

Drainage Fixture Units	Interceptor Volume (min.)
8	500
21	750
35	1000
90	1250
172	1500
216	2000
307	2500
342	3000

Example: Commercial sink with food waste with 1-1/2" trap, plus mop sink and special purpose sink 2" trap. **3+3+3=9 (DFU)**

Referencing table below 9 DFU will require 750 gallon min. interceptor volume.

Floor Drains & Floor Sinks: Take the volume of water produced by the number of hose bibs (ie 1.5-2.0 gpm per 3/4" faucet)

Note: Capacity sizing is typically applied to gravity grease interceptors (GGI) resulting in a liquid capacity that is substantially greater than an equivalent hydromechanical GI. **An HGI due to its qualified efficiency and grease capacity at breakdown (when efficiency falls below 90%) results in actual grease capacity that is operationally equivalent to a GGI that is 5-6 times that of the HGI.**

How can I convert DFU to GPM?

The conversion of DFU (Discharge Fixture Units) to Flow Rate equivalent is not directly achievable by application of a standard formula. As an experienced manufacturer in the Grease Management market, we have been able to identify and validate a method of conversion that references accepted engineering data and applies the following approach. This method is offered as a **manufacturers recommended method of conversion** to determine Hydromechanical Grease Interceptor equivalency, to a respective Gravity Grease Interceptor volume where initially determined by total calculated DFU discharge.

Step 1: Determine the total DFU discharge by following applicable code-defined methods and using UPC Table 1014.3.6 as a basis. The total DFU is used to identify the respective Gravity Interceptor volume (US Gallons).

Step 2: Multiply the selected volume by 2 (Equivalency Factor) and divide the result by 30 (min). 30 minutes is the typical retention time used as the basis of design for Gravity Grease Interceptor (GGI) volume.

Example: At 50DFU discharge, a 1250 gallon Gravity Grease Interceptor (GGI) is identified by the table. Therefore, 1250 (USG) x2 (Equivalency Factor) = 2500USG. Now divide the 2500gallons by the 30 minute retention time and the output is 83.3GPM. Using established practice, this number is rounded up to the next standard size of interceptor available and so conversion of a 1250USG Gravity Grease Interceptor is considered to be a 100GPM Hydromechanical GI.



For sizing assistance visit www.SizeMyGI.net



Need Technical Support?

Canada

1-800-461-1771

U.S.A.

1-888-461-5307

Email: tech-support@endurainterceptor.com

Do Endura® XL tanks need to be directly vented?

The practice of venting a grease interceptor directly is typically related to Gravity Grease Interceptors (GGI). Unless specifically mandated by local code or bylaw, with no variance allowed, a Hydromechanical Grease Interceptor (HGI) DOES NOT require the tank to be directly vented. Venting is however required on the downstream drain the same as most plumbing appliances, fixtures to allow effective and unrestricted discharge of effluent.

Do I need to install a clean out before or after an interceptor?

Most plumbing codes require an upstream and downstream cleanout immediately before and after the interceptor. **This is good practice and gives positive indication of which outlet is in use.**

Do I have to install the Flow Control Device?

For an HGI, the Flow Control is ESSENTIAL to the high performance operation of the interceptor. It must be installed as indicated and without it the interceptor is no longer meeting the requirements of its appropriate approvals. This is not acceptable to the AHJ and they should be asking for the installation to be rectified before approval is granted.

My jurisdiction requires effluent sampling via a downstream access. What do I do?

As an HGI approved to National performance Standards and although common for GGI (Concrete, Steel), Endura® XL **DOES NOT** typically required a separate sampling location. For those jurisdictions that do require the capability to sample, Endura® XL incorporates a sampling port within the outlet assembly. This is accessed by the simple removal of the air balance/sample port cap (See Page 16) allowing water quality samples to be taken for analysis. Some AHJ's may require a separate downstream sampling point. Contact us for assistance.

What can be connected to an interceptor in respect of wastewater discharge?

A grease interceptor **UNDER NO CIRCUMSTANCES** will receive sanitary wastewater discharge – i.e. that from WC flushing for example.

Wastewater discharge to a grease interceptor will be from foodservice activities only, its application being to separate **non petroleum Fats Oil and Grease** from waste water.

The requirements for appliances and fixtures that must and must not be connected to a grease interceptor is typically defined by your local plumbing codes and or jurisdictional by-laws. You should consult a licensed plumbing professional or your local city plan check or plumbing code officials for clarification regarding right schedule of maintenance for your application/premises.

How often should an interceptor be cleaned?

Cleaning of an interceptor is a case by case situation. Each facility will have many different factors impacting need for maintenance and cleaning. A licensed contractor will have the experience and equipment necessary to help establish the right schedule of maintenance for your facility.

How much will it cost to maintain my Endura® XL installation?

In terms of comparison Endura® XL units are significantly more compact (less internal volume) than their equivalent Gravity counterparts. As pumping is typically charged by the volume of gallons removed the ongoing maintenance will be proportionally less too. Rates will vary significantly by region and by contractor. Always use a licensed or approved contractor to maintain your interceptor

Can I install more than one Endura® XL unit if my jurisdiction needs a minimum capacity by code?

In principal, yes you can. It will be necessary for you to contact your plan check or review team at the authority having jurisdiction and have your engineer submit a proposal based on the reference information provided on Page 10 of this document. Full spec drawings (BIM & Master Specs) are available for download at www.arcata.com using the search term "endura".

How does a compact HGI replace the function of a 1000 gallon concrete tank?

A Gravity Grease Interceptor (your typical concrete tank) will be sized on capacity and therefore typically a number between 750gallons and 1500gallons is commonly seen. This number can however be substantially higher based on local requirement or application. In most jurisdictions, a method called the 25% rule is employed as the means to indicate or mandate the cleaning frequency. The 25% is the percentage of the total working volume of the interceptor which can be occupied by a combination of Fats , Oil and Grease and Food Solids.

For example: A GGI tank with a capacity of 1000 gallons can only function to a point where 250gallons (1000 X .25) of its volume is occupied by solids and grease. That equates to approximately 1090 lbs of grease. If we assumed that 100 gallons of this is the solid material, that leaves 150 gallons of grease capacity before cleaning is "required". On average this translates to approximately 8-10 weeks on average. Now compare this to an XL100 HGI. Based on the independent third party testing to determine qualified performance & efficiency, the Endura® XL100 has a significantly smaller 257gallon total capacity, but a qualified efficiency exceeding 98%. This translates to essentially the same grease capacity as the GGI, exceeding 1000lbs of functional grease capacity.

I heard that plastic tanks can float in high water table areas, particularly when pumped down for cleaning. Is this true?

Yes it is, however Endura® XL is specifically designed to address this challenge. If you look at XL tanks from the end you will see that the top is narrower than the bottom and that there are along the sides corrugations that are closed toward the bottom of their profile. This profile is the reverse of an ice cube sitting in a freezer tray. Typically some upward force is applied around or beneath the ice cube and out it pops! Now reverse that principle to the form of the tanks – the broad base not only provides stability but also has substantial resistance to being forced upward by water or freeze-thaw action. This in conjunction with the closed corrugations positively captures the tank in the excavation once backfilled. For areas of particular concern in addition an 8" concrete slab can be poured around the base to introduce further resistance. Provision is also made for the use of ground anchors or alternates that will need to be specified locally by an engineer respective of local ground conditions.

Have feedback?

Email us at... feedback@endurainterceptor.com

Limited Lifetime Warranty

Canplas Industries Ltd. hereafter referred to as “Manufacturer” guarantees to the original consumer purchaser (“Original Purchaser”) of Endura® XL Grease Management Products (hereafter referred to as “Products”) that Manufacturer will replace any such Products that are defective in materials or workmanship, subject to the limitations detailed herein. If replacement is not commercially practical or cannot be made in a timely manner, then the Manufacturer will, at its discretion, refund the purchase price. This warranty applies only to Products installed in a commercial application. THIS EXPRESS WARRANTY IS IN LIEU OF AND EXCLUDES ALL OTHER WARRANTIES, WHETHER EXPRESSED, IMPLIED OR STATUTORY, INCLUDING IMPLIED WARRANTIES OF MERCHANTABILITY OR FITNESS FOR A PARTICULAR PURPOSE. THIS EXPRESS WARRANTY SPECIFICALLY EXCLUDES INSTALLATION AND/OR REPAIR COSTS, INCLUDING LABOUR.

The Products have a limited warranty from the date of purchase against defects in workmanship and materials. Any Product believed to be defective must be returned to the Manufacturers’ manufacturing facility located at 31 Patterson Road, Barrie, Ontario, Canada L4N 3V9 with freight prepaid, or, at Manufacturers’ sole discretion, an on-site inspection may be arranged. The Manufacturer reserves the right to inspect all allegedly defective Products. Any products found to be defective following examinations will be replaced free of charge and returned freight prepaid at the absolute discretion of the Manufacturer. All products returned under this warranty must have proof of purchase information included.

Limitations

This Warranty applies provided that the Products have been installed in strict compliance with the Manufacturers’ written instructions, as published from time to time, and in accordance with all local codes and standards. This Warranty does not cover any labour costs, including those required for field repair or replacement or removal of any allegedly defective part. This Warranty does not cover any consequential, incidental, special or punitive damages related to the allegedly defective Product.

This Warranty does not cover damage or defects as a result of normal wear and tear, improper operation, abuse or alterations to the Products, if the Products have been used in more than one installation, installed in improper applications, acts of nature, building settling, structural failures of constructed walls or foundations, improper installation, storage, handling, failure to properly care for and maintain the Products or any other cause outside the control of the Manufacturer.

The Manufacturer reserves the right to discontinue or modify any of its Products at its absolute discretion, and shall not be liable as a result of such discontinuation or modification. The Manufacturer may replace any product under this Warranty, at its absolute discretion, with substitute Products of comparable quality and/or price range in the event the original Product has been discontinued or modified.

Transferability

In the event of a change in ownership the Warranty may be transferred by the Original Purchaser of the Product to the first subsequent owner, subject to the terms and conditions of this Warranty.

Other Conditions

This Warranty is expressly in lieu of all other oral or written warranties, liabilities or obligations of the Manufacturer. Pertinent State, Provincial or Federal law shall control for what period of time subsequent to sale an owner may seek a remedy pursuant to the implied warranty of merchantability or fitness for a particular purpose. In no event, shall the Manufacturer be liable for consequential or incidental damages of any kind, including any damage to the building, its contents or any persons therein, resulting from the breach of any warranty set forth herein, unless exclusion of these types of damages are specifically prohibited by State, Provincial or Federal law. No field representative of the Manufacturer or any distributor or dealer is authorized to make any change or modifications to this Warranty. While this Warranty gives you specific legal rights you may also have other rights that vary depending on your locality.

Important:

Limited Lifetime Warranty Registration Card

Congratulations on your purchase of the Endura® XL Grease Interceptor. **This product is supplied with a Limited Lifetime warranty (see page 23), valid only when this warranty card is filled out and returned to the manufacturer.**

Online warranty registration at www.EnduraWarranty.com

<p>• Client/Installation Location</p>	<p>• Size of Grease Interceptor installed?</p>
<p>Name: _____</p>	<p><input type="checkbox"/> 75 gpm <input type="checkbox"/> Threaded Connection</p>
<p>Address: _____</p>	<p><input type="checkbox"/> 100 gpm <input type="checkbox"/> No-Hub Connection</p>
<p>Tel: _____</p>	<p>• Flow Control Format? <input type="checkbox"/> Internal Flow Control <input type="checkbox"/> External Flow Control</p>
<p>Fax: _____</p>	<p>• Is this installation...</p>
<p>• Contractor/Installer (Print):</p>	<p><input type="checkbox"/> New <input type="checkbox"/> Replacement</p>
<p>Name: _____</p>	<p>• Where was it installed?</p>
<p>Company: _____</p>	<p><input type="checkbox"/> On Floor <input type="checkbox"/> In Floor - Inside Building <input type="checkbox"/> Floor Below (eg. basement)</p>
<p>Address: _____</p>	<p><input type="checkbox"/> In-Ground - Outside building</p>
<p>Tel : _____</p>	<p>• How did you hear about the product?</p>
<p>Fax : _____</p>	<p><input type="checkbox"/> Supplier <input type="checkbox"/> Trade Show <input type="checkbox"/> Trade Magazine <input type="checkbox"/> Specified</p>
<p>Installer Signature</p>	<p><input type="checkbox"/> Referral <input type="checkbox"/> Online</p>
<p>• Purchased From:</p>	<p>• Was this the first Endura® XL Grease Interceptor you have installed?</p>
<p>Name: _____</p>	<p><input type="checkbox"/> Yes <input type="checkbox"/> No</p>
<p>Address: _____</p>	<p>• How do you rate Endura® XL based on experience of past installations?</p>
<p>Tel: _____</p>	<p><input type="checkbox"/> <input type="checkbox"/> <input type="checkbox"/> <input type="checkbox"/> <input type="checkbox"/> <input type="checkbox"/> <input type="checkbox"/> <input type="checkbox"/> <input type="checkbox"/> <input type="checkbox"/> <input type="checkbox"/> <input type="checkbox"/></p>
<p>Fax: _____</p>	<p>1 2 3 4 5 6 7 8 9 10</p>
<p>Have feedback? Email us... feedback@endurainterceptor.com</p>	

<p>Canada Tel: (705) 726-3361 1-800-461-1771 Fax: (705) 726-2186</p>	<p>U.S.A. Tel: (303) 373-1918 1-888-461-5307 Fax: (303) 373-1923</p>
---	---

 Technical Support
tech-support@endurainterceptor.com