



Item No.: _____
 Order No.: _____
 Qty: _____ Date: _____

Features

- SS304 tub
- High density closed cell polyurethane insulation
- Ø1" NPT Drain
- ETL certified for food service application
- Include removable bars to support pans



Description Ice Cool Cold Pans

Keep your most popular cold foods chilled throughout the day! This food well is designed to be used with ice so that you can keep cold foods at safe holding temperatures in locations without electricity. Its spacious interior has enough room to fit multiple food pans. The 1" drain siphons runoff and melted ice from inside the well, and the entire unit is insulated with polyurethane foam to ensure premium energy efficiency. And thanks to its stainless steel construction, this food well has outstanding durability.

Plan View IP4526

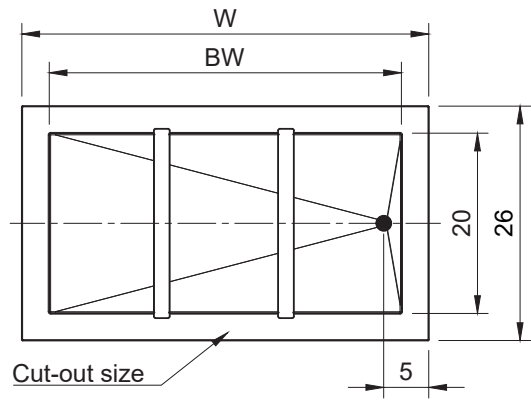
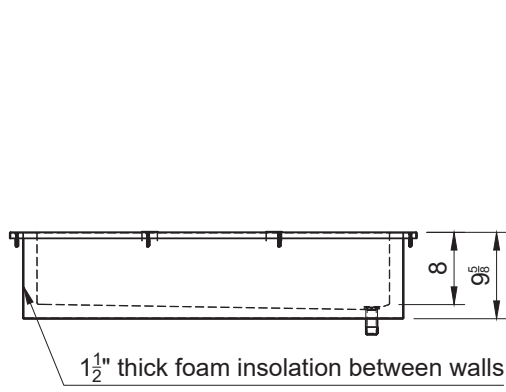

Order No.	W (in)	BW (in)	Pan	Cut-out Size (in)	G. W. (lb)	Pack/ case
IP1826	18	11-7/8	1	24-1/2 x 16-1/4	35	1
IP3126	31-5/8	25-1/2	2	24-1/2 x 30	54	1
IP4526	45-5/8	39-1/4	3	24-1/2 x 43-3/4	73	1
IP5926	59-1/2	53	4	24-1/2 x 57-1/2	94	1
IP7226	73-1/8	66-3/4	5	71-1/4	113	1