



SANDWICH/ SALAD PREP REFRIGERATORS

MEGA-TOP



PSTX29-MT



PSTX48-MT



PSTX70-MT

Model	Size
PSTX29-MT	29" Unit
PSTX48-MT	46" Unit
PSTX60-MT	60" Unit
PSTX70-MT	70" Unit

Standard Features

- Stainless steel interior and exterior, aluminum back. Option of bright white aluminum interior available.
- Refrigeration system keeps food at safe temperatures between 33°F and 41°F
- Self-Closing doors with 90 degree stay-open feature.
- Cutting boards and pans available.
- Shelves: Adjustable heavy-duty PVC coated shelves.
- Option of different handles available.
- Electronic control system makes it easy to adjust temperature set point and defrost frequency
- Pre-installed heavy-duty casters with brakes
- Removable installation board makes it easy to access condenser coil for cleaning and service
- These units use HYDRO-CARBON R290 refrigerant which is environmentally friendly and more efficient than R134a/R404a refrigerant



SANDWICH/ SALAD PREP REFRIGERATORS MEGA-TOP

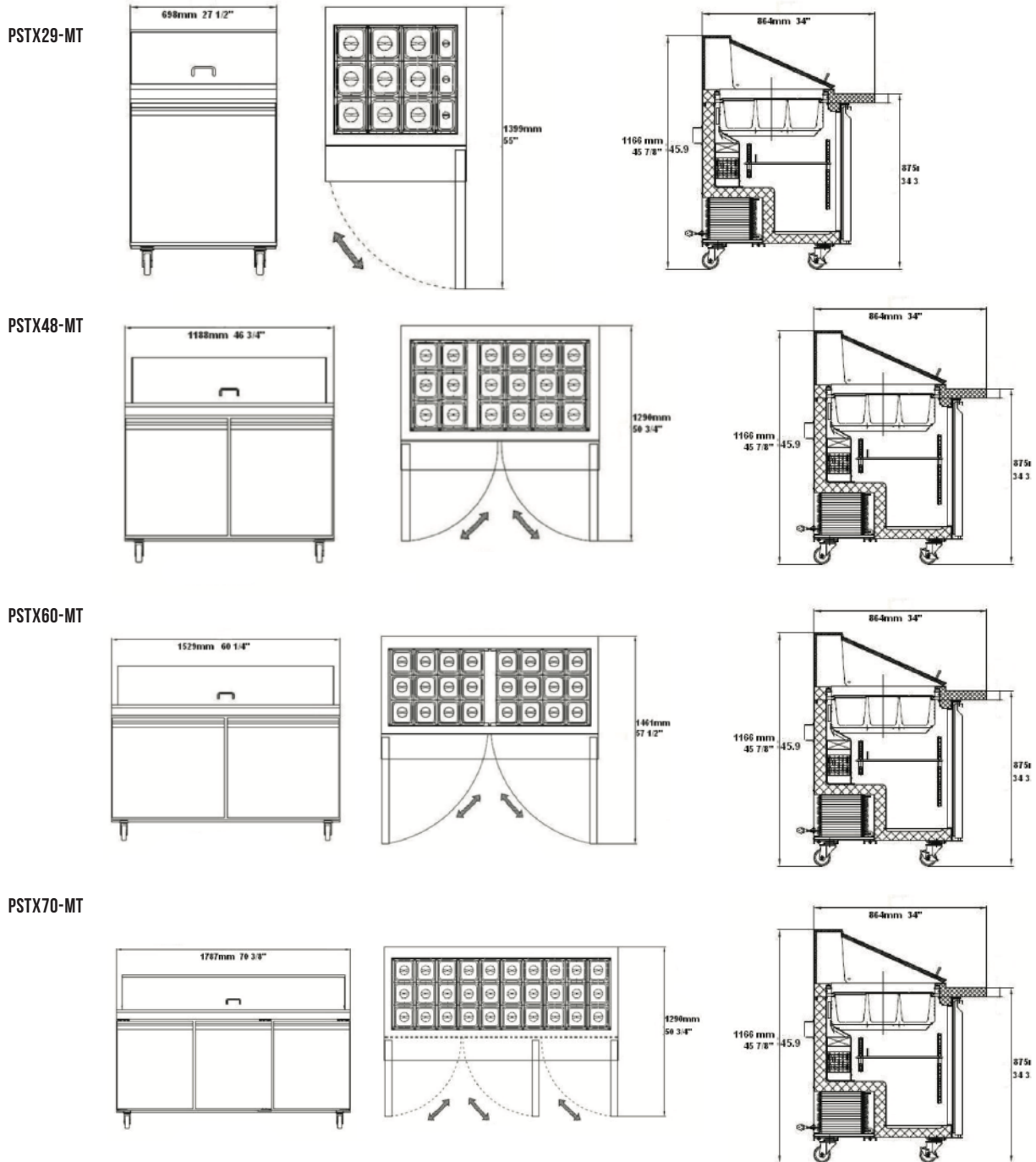

Model	Doors	Capacity (Cu-ft)	Shelves	Cabinet Dim (in) External			HP	Voltage	Amps	NEMA Plug
				L	D	H				
PSTX29-MT	1	7	1	27.5	29.5	42.375	1/5	115/60/1	2.88	5-15P
PSTX48-MT	2	12	2	46.875	29.5	42.375	1/4+	115/60/1	4.56	5-15P
PSTX60-MT	2	15	2	60.2	29.5	42.375	1/4+	115/60/1	4.8	5-15P
PSTX70-MT	3	15.5	3	70.4	29.5	42.375	3/4	115/60/1	8.9	5-15P

Specifications are subject to change.