

Project:	Quantity:
Model #:	Approval:

*For Commercial Use Only*

## GSTC74-5S 74" Five Well Gas Hot Food Steam Table with Enclosed Base

### FEATURES

- Removable 1/2" thick poly cutting board
- Stainless steel construction
- 5 Powerful Jet burners
- Sliding doors with handle
- Legs included
- Fiberglass insulation between wells
- Gas regulator included
- Independent heat controls
- Built-in water drain
- Sealed well design for water heat  
(no spillage pans needed)

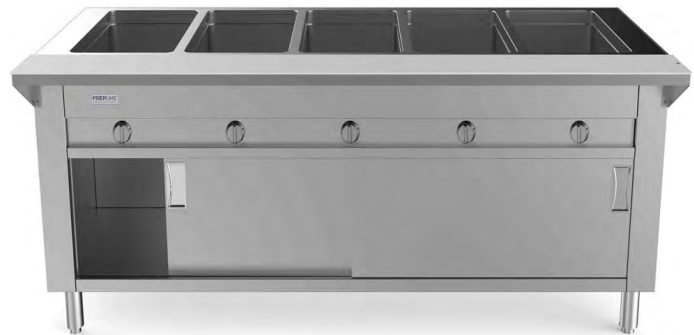

- cETLus
- ETL-Sanitation

Certified to NSF Standard



### Optional Lighted Sneeze Guard

- 74" Lighted Heated Sneeze Guard
- Four side tempered glass
- Includes four heat lamp bulbs
- Prevents contamination

This 60" food service glass sneeze guard display features stainless steel frame with four sides tempered glass, allowing customers excellent views of your food from all angles. The standard 120V makes set up easy.



**U**SR Brands is a US supplier of premium quality commercial cooking, refrigeration and food preparation equipment. Our aim is simple. Produce industry-leading commercial restaurant equipment at reasonable prices, and back it all up with an easy to understand, no nonsense warranty that people can count on.

For Commercial Use Only

TECHNICAL DATA

MODEL	Exterior Dimension	Number of Well(s)	Number of Burner(s)	BTU per Burner	Total BTU	Well Type	Body Type
GSTC74-5S	74" x 30.6" x 34.4"	5	5	3,500BTU	17,500BTU	Sealed Well	Cabinet

TECHNICAL DRAWING

SKU: GSTC74-5S

MFR ITEM #:

FRONT

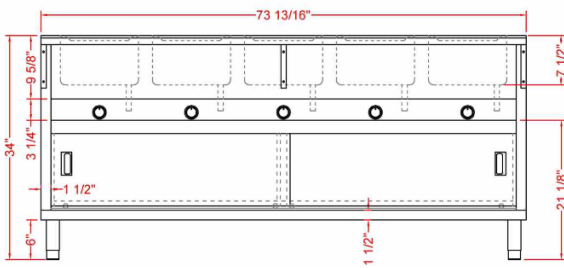

SIDE

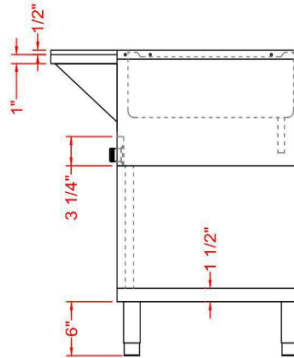

TOP

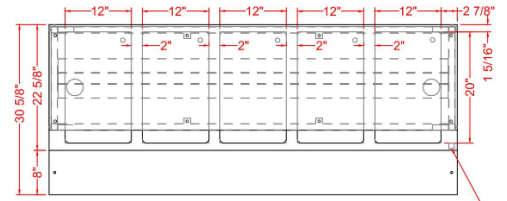

Optional Lighted Sneeze Guard

FRONT

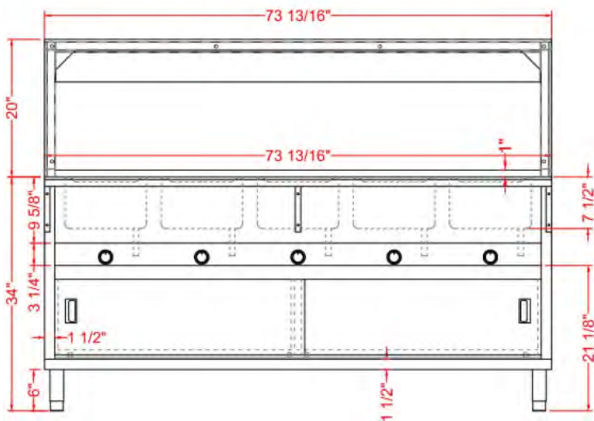

SIDE

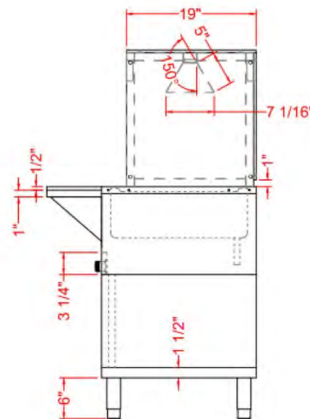

TOP

