



PROJECT NAME: \_\_\_\_\_

LOCATION: \_\_\_\_\_ ITEM: \_\_\_\_\_

QTY: \_\_\_\_\_ MODEL: \_\_\_\_\_

## C3240E -SB ELECTRIC CONVEYOR OVEN – STONE BELT

The IKON C3240E-SB Electric Conveyor Oven is equipped with an innovative refractory stone conveyor belt. Achieve stone-baked results with the convenience of a conveyor oven system. Independent temperature controls for both the upper and lower oven sections and high temperature cooking allow for precise baking performance. Bake authentic pizzas, focaccia, pita bread, tortillas, vegetables, brochette, tarts , chicken wings, meats and more in an oven unlike any other.

### STANDARD FEATURES

Patented EMS Energy Management System reduces energy consumption and increases cooking efficiency

Independent digital temperature controls for upper and lower baking zones

40” (103cm) long cooking chamber with 32” (81.5cm) width stone tile conveyor belt

Maximum cooking temperature 842 °F (450 °C)

#### Conserves Energy

Unit incorporates a patented Energy Management System. IKON ovens provide very efficient heat transfer to product. Energy is conserved as air is recycled from heater to product, with minimum loss. Oven is cool to the touch.

#### Easily Services

Control compartment is designed for quick and easy access.

Self-lubricated bearings for simplified maintenance

Digital control bake time and conveyor speed

Stainless steel front, sides, top and interior

Crumb-collecting removable trays for easier cleaning

Reversible conveyor direction

Adjustable inlet and outlet shutters

Durable support stand with heavy duty casters

#### Cleanability

C3240E-SB Oven removable parts include: crumb pans, side shutters , stone tiles. Attached steel brush makes it easy to clean carbon dust buildup on stone tiles.

#### Warranty

One year parts and labor warranty

#### Ventilation

Use of a ventilation hood is strongly recommended.

THIS OVEN CAN BE DOUBLE STACKED

Note: If double stacked an optional support stand with short legs must be ordered.



www.mvpgroupcorp.com



3560 NW 56th Street  
Fort Lauderdale, FL 33309  
Tel.: 786.600.4687 / Toll Free: 844.218.8477



5659 Royalmount Avenue  
Montreal, Qc, Canada H4P 2P9  
Tel.: 514.737.9701 / Toll Free: 888.275.4538  
Fax.: 514.342.3854 / Toll Free: 877.453.8832

sales@mvpgroupcorp.com

# TECHNICAL DRAWINGS

ELECTRIC CONVEYOR OVEN – STONE BELT  
C3240E-SB

**Powerful Heat**  
Bake at up to 842°F

**Expandable Capacity**  
Stack up to two units, doubling total output

**Dual-temp baking system**  
Independent baking controls for upper and lower sections and adjustable conveyor speed guarantee perfect cooking results

**Cooks up to 32" Pizza**  
A true 32 inch wide belt fits standard large pizza trays

**Intelligent Digital Controls**  
Precise temperature control

**Crumb Tray**  
Removable crumb tray makes cleanup easy

**Refractory Stone Tiles**  
Innovative stone conveyor belt combines the best of a stone and conveyor technology. Cook fast at up to 842°F - with a 70% increase in capacity compared to a traditional steel conveyor oven.

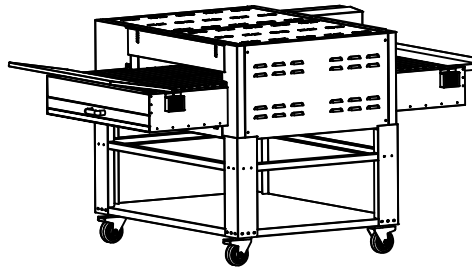

(Top View)

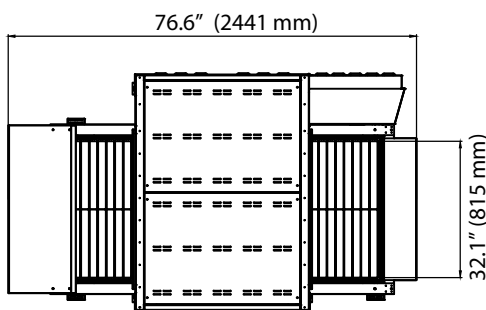

(Main View)

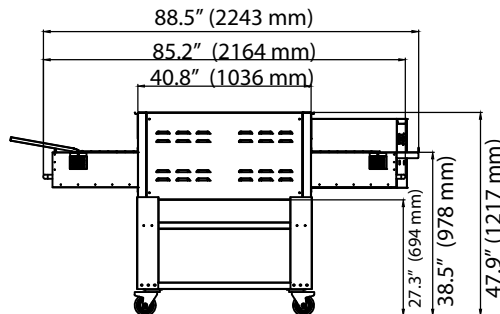

(Left View)

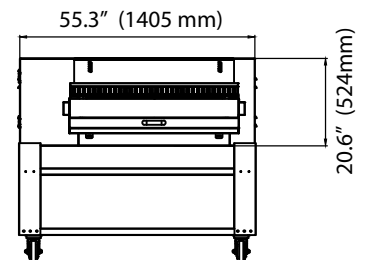

## SPECIFICATIONS

Model	Heating Chamber Size / Belt Size	Max. Bake Height	Conveyor Time Setting	Max. Temp.	Power	Supply	Ship Info.*	Capacity		
								9"	12"	15"
C3240E-SB	32" x 41" (815 x 800 mm) 32" x 76.6" (815 x 1946 mm)	4" (106 mm)	1.5 - 20 min	842°F 450°C	31.8 Kw 48A	208-220V 3 Phase	1279 lb (580 kg) 64 ft <sup>3</sup> (1.8 m <sup>3</sup> )	500	350	200

\*Ship Info. : Data of package with plywood case

\*Capacity : Average 12"-14" pizza, 40 pizzas per hour / every 3 minutes in chamber. Times and quantities vary depending on product being cooked

Warranty: One year parts & labor

IKON is a registered trademark of MVP Group

Due to continuing product development, to ensure best possible performance, the specifications are subject to change without prior notice.



www.mvpgroupcorp.com



3560 NW 56th Street  
Fort Lauderdale, FL 33309  
Tel.: 786.600.4687 / Toll Free: 844.218.8477



5659 Royalmount Avenue  
Montreal, Qc, Canada H4P 2P9  
Tel.: 514.737.9701 / Toll Free: 888.275.4538  
Fax.: 514.342.3854 / Toll Free: 877.453.8832

sales@mvpgroupcorp.com