

AT82G

ACT.O GAS COMBI OVEN 8X2/1 GN

Multifunction mixed oven with advanced technology. Control panel 10", 100% touchscreen, high resolution. Customizable control panel. Extensive program library. Multi-point core cooking probe 5 monitoring points. Immediate steam production in a controlled and modulated overpressure environment. Manual, automatic or memorized cooking programs. Special Cooking: Low Temperature, Delta T, Reheat, Dehydrate, Hot and Cold smoke, Pasteurization, Vacuum and Sous Vide. Compatible with smoker accessory. Double fan rotation direction with 6 speeds. Washing and automatic descaling system of the cooking chamber through adding of Power Pearls micro-granules. AISI304 and AISI316L stainless steel construction for the upper and lower parts of the cooking chamber, fan and container rack.



Automatic washing with micro-granules



<i>Automatic cooking</i>	Yes	<i>Automatic washing</i>	high-efficiency water and detergent recirculation pump
<i>Capacity in GN containers</i>	8 x 2/1GN	<i>Chemical products to be used</i>	Detergent in Power Pearls micro-granules and descaling
<i>Display</i>	10" capacitive touchscreen with scroller selector	<i>Door knob</i>	right-hand opening even with full hands
<i>Energy Control</i>	Pre-Setting for remote control of power peaks	<i>Portions for cooking process</i>	n° 223
<i>Power supply</i>	Electricity	<i>Product core probe</i>	Electricity
<i>Simultaneous cooking</i>	Automatic and Multi-timer		

Functional features

- Multi-Function Combi Oven with high definition 10" touchscreen control panel.
- Two modes of access to function and data selection: either via the touchscreen or using the knob, with press to confirm.
- Easy, intuitive control function navigation.
- User profiles can be configured with hierarchical access levels or restricted access depending on operator category. The administrator has a password granting access to all functions. Ordinary users have limited access to the functions assigned to them by the administrator.
- Personalization of homepages for different users
- "Weekly scheduler" function integrated in the control software, for entering recurrent, personal or working commitments, with alerts on the oven display as they come due, with direct entry to the cooking or washing processes put in the scheduler; automatic start of cooking and washing processes can be programmed.
- Three cooking control modes. 1. Manual: the user can set up to 5 different cooking phases; 2. Memorize up to 18 consecutive phases: the user selects a stored program and can edit it; 3. Automatic: the oven offers cooking cycles by category of food and the user can personalize the result required.
- The main cooking modes are convection, steam and combined.
- STEAM COOKING: from 86 to 257°F with three separate steam generation levels, selected to suit the cooking result required.
- COMBINED COOKING: from 86 to 482°F, with active control of cooking humidity from 10 to 90%, in 5% steps.
- Active control of cooking environment by "AOC" balanced cooking chamber closure system, for effective saturation in a closed environment during steam cooking, or active management of excessive cooking moisture removal in combined mode.
- "RDC+EVOS" high efficiency steam generation system with low operating costs. Instantaneous steam production in an enclosed environment at controlled, modulated pressure.

ACT.O GAS COMBI OVEN 8X2/1 GN

AT82G

- Special Cooking Functions: Holding, Delta T, Reheating, Sous-vide, Low Temperature, In-Jar Pasteurization, Smoking, Vacuum and Dehydrating.
- Cooking program library: 274 processes in the MULTI.ACTO menu, 105 processes in the AUTOMATIC COOKING menu, 77 processes in the MULTI-PHASE COOKING menu, 48 processes in the SPECIAL COOKING menu. Each stored cooking process includes a written recipe and an image of the mise en place. This function also applies to new cooking programs entered directly by the user.
- Automatic warning for periodic maintenance.
- MULTI ACT.O function: simultaneous control of several dishes cooked in different compatible modes. A name can be assigned to every cooking cycle. MULTI-ACTO offers a library of 200 editable stored cooking processes classified in 11 families. My-Menu customization function.
- MULTI.TIMER function (up to 20 different times): control of simultaneous cooking operations with the same cooking mode and different times.
- ECO function to reduce energy and water consumption during both cooking and washing.
- "Continue Cooking" function offered at the end of the cooking process, which maintains the settings.
- Manual timed steam injection (1 to 59 seconds).
- Cooking process execution times 0 to 24 hours, with option of cooking time control by the second.
- Simultaneous control of cooking with 2 core probes - (multi-point probe supplied as standard plus optional additional vacuum or multi-point probe).
- 6 fan speed settings, including one semi-static. Alternating fan rotation.
- Provision for remote control of the oven - using the network produced within the facility by the router - by means of a highly reliable mirror software package, with reproduction of the display on iOS, Android and Windows devices.
- Provision for remote communication via Internet connection (Wi-Fi or Ethernet) using the IOT (Internet Of Things) technology, to send and receive data from the secure access cloud using the portal APO.LINK. The operator can view the cooking and washing data log, the HACCP data, the efficiency parameters (KPI) and the alarms, and send cooking programs to the oven.
- Download and upload functions (cooking programs, software updates, HACCP data, oven backup) via USB.
- Automatic, high efficiency washing and descaling system with water and detergent recycled inside the cooking chamber (patent pending), the breather pipe and the heat exchanger/fan compartment, with 4 automatic washing programs, 2 automatic descaling programs and 1 rinsing process.
- Effective, powerful, uniform washing even with low inlet water pressure.
- Automatic washing using POWER PEARLS as standard, or with liquid detergent via accessory.
- Oven can be programmed with a washing alert.
- Alarms reset button. Self-diagnosis with malfunction alarms.
- Multilingual.
- Automatic cooling and preheating.
- Provision for remote peak power cut.
- Switch-on time setting.

Construction features

- Constructed in stainless steel, with cooking chamber polished to mirror finish, top and bottom in AISI 316L (0.047"), side surface in AISI 304 and joint-free rounded edges.
- Removable container rack structure in electro-polished AISI 316 stainless steel, able to take GN 1/1, GN 2/3 and GN 1/2 containers and grids without connecting shelf.
- Special rack profile with holes for optimized washing.
- Easily removable container rack structure with 4 fixing points.
- Armoured direct heat exchanger, in incoloy 800, in cooking chamber.
- High aerodynamic efficiency cooking chamber fan, and AISI 316 "RDC" steam generator.
- Lighting in the cooking chamber with LED lights.
- Control panel with capacitive touchscreen protected by 4 mm tempered glass.
- "Folding" partition between cooking chamber and heat exchanger compartment, with easily accessed fixing system.
- Door with intermediate stop positions at 90° and 130°, open cavity 6+6 mm tempered glass double glazing and low emissivity removable inner glass.
- Component section shielded from heat by two insulating panels, in glass wool (2+3 cm).
- Nickel plated metal knob.
- Two-grip handle, easy to open even with hands full, with nickel plated trims and thermally insulated inserts.
- High-strength silicone door seal with two heat barrier lines.
- Condensate collection and drainage containers integrated in the door and the front of the oven.
- Technical compartment with all functional components, accessible from left-hand side of oven. Forced cooling with expanded polyurethane air filter.
- Cooking chamber drain in bottom with trap, ventilated and with system to prevent liquid/odour flowback.
- Provision for installation of connector for second core cooking probe, to take either multipoint or vacuum probe.
- Provision for smoking kit (SMOK).
- Provision for accessory for advanced control of pasteurisation process in jar (FMP), with multipoint core cooking probe.
- Automatic washing system with water and detergent recycling. Bottom collection tank in AISI 304 stainless steel with high efficiency recycling pump.
- Provision for dispenser accessory for automatic feeding of liquid chemicals (single washing detergent and separate descaler product).
- Prefitted to take Wi-Fi connection kit accessory (KIOT).

ACT.O GAS COMBI OVEN 8X2/1 GN

AT82E

Safety equipment and approvals

- Thermal protection and safety thermostats, connected to relative alarms, for fan motor, cooking chamber, control circuit board and inverter.
- Automatic cooling of the cooking chamber with door closed.
- Height of top container slide 160 cm or less with original supporting frame.
- Magnetic door microswitch.
- Self-diagnosis with alarms for motor cut-out due to water supply failure or other reasons. Alarm decoding on control panel.
- Fan rotation cutout when door is opened.
- IPX5 protection rating.

Standard equipment

- Increasing density multipoint core cooking probe with 5 monitoring points. Hook for stowing probe in protected position when not in use.
- Removable container rack, capacity 8 x GN 2/1 or 16 x GN 1/1 containers, level interspace 69.5 mm.
- Feet h 100 mm finished with AISI 304, with adjustable height.
- User manual with cooking advice.
- After-sales service data.
- Sachets of Power Pearls detergent.

Technical Data

<i>Working voltage</i>	120V 1Ph ~ 60 Hz	<i>Electric Power</i>	XXX
<i>Dimensions</i>	46.46" x 42.68" x 39.06"	<i>Packing</i>	50.39" x 43.5" x 49.61"
<i>Weight</i>	440 lbs	<i>Packing weight</i>	519 lbs

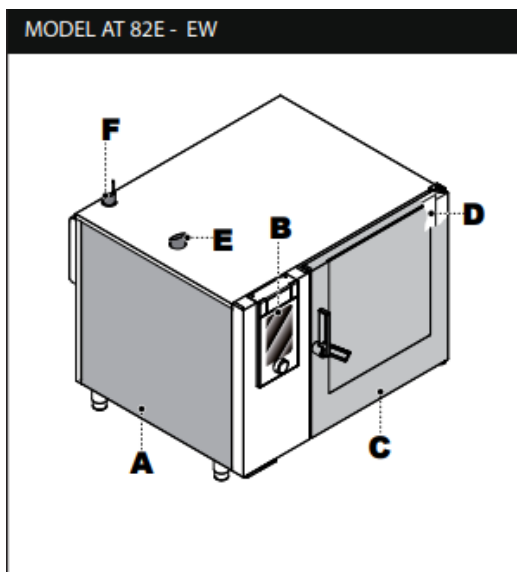

Main Parts

- A) Electrical component compartment panel
- B) Control board
- C) Oven door
- D) Cooking chamber
- E) Air intake and steam exhaust pipe
- F) Steam exhaust pipe