

 **General Information**

Project Name: _____

Consultant: _____

Item #: _____

Model #: _____

Quantity: _____



Model SMCC-29
Shown w/ optional
Tray Slides

 **Specifications**

Top: 16GA stainless steel type 300 series with 2" channel edge, all corners welded, ground and polished. Stainless Steel channel bracing provided as necessary.

Frame: 14GA stainless steel multi-formed, fully welded vertical corner uprights.

Apron: 18GA stainless steel, 10" apron welded to framework.

Casters: 5" Heavy Duty ball bearing swivel casters, (2) with brakes.

Interlocking Device: As required, quick release latches are provided to join units together.

 **Product Guide**

Modular Corner Counters featured with a heavy duty solid top. These space saving units are used for displaying food or as a general purpose work counter. These sturdy units are designed for long lasting service. Units are provided with interlocking devices for quick and easy assembly and disconnecting.

 **Options**

- Tray Slide (Solid) - 12" Wide
- Tray Slide (Three Bar) - 12" Wide
- Display Case (2-Tier)
- Protector Case
- Single Service Sneeze Guards
- Double Service Sneeze Guard
- Fluorescent Light
- Work Shelf
- Work Shelf w/ Poly Top
- Plate Shelf
- Full Front Panel (Laminate)
- Full End Panel (Laminate)
- Intermediate Undershell
- Convenience Outlets - ____ (ea.)
- 14GA Top Upgrade
- Backsplash (6" High)
- Return Splash (6" High R/L)
- Laminate Doors
- Kick Base - Stainless Steel
- Correctional Package
- Sink - specify size: _____
- Lever Drain
- Legs w/ Bullet Feet
- Doors - Stainless Steel
- Lever Drain w/ Overflow
- Receptacle Bracket - ____ (ea.)
- Drawer(s) - ____ (ea.)
- Sound Deadended Top
- Infrared Heat Lamp



SMCC-50 0919

DRAWINGS

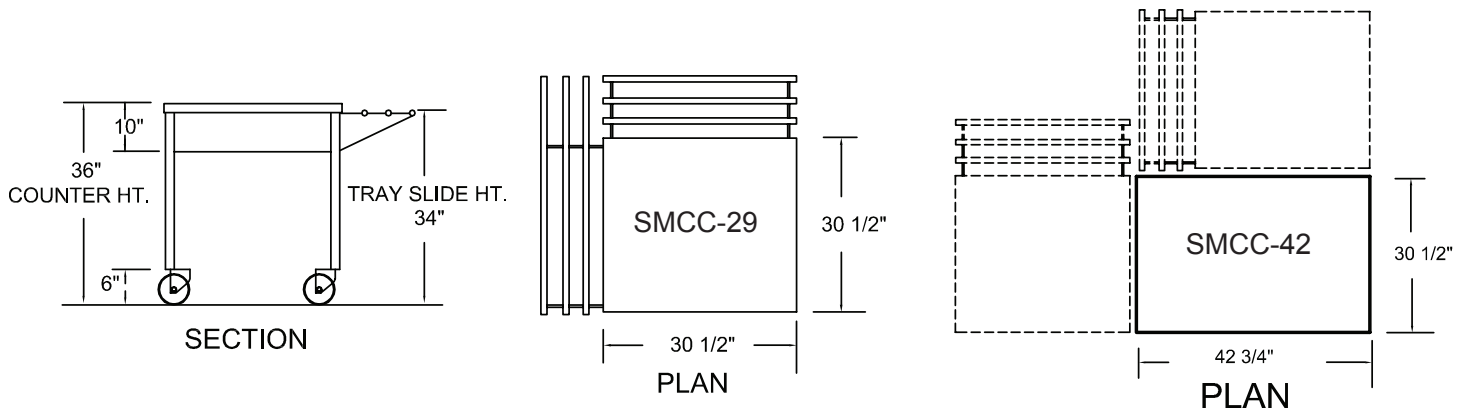

CORNER COUNTER

Model	Size (W x L x H)
□ SMCC-29	30 1/2" x 30 1/2" x 36"
□ SMCC-42	30 1/2" x 42 3/4" x 36"

RECOMMENDED COUNTER HEIGHT FOR SCHOOLS

- HIGH SCHOOL - STANDARD HEIGHT: 36" COUNTER HEIGHT - 34" TRAY SLIDE HEIGHT
- INTERMEDIATE SCHOOL: 34" COUNTER HEIGHT - 32" TRAY SLIDE HEIGHT
- ELEMENTARY SCHOOL: 32" COUNTER HEIGHT - 30" TRAY SLIDE HEIGHT

Specifications subject to change without notice.

SMCC-50 0919