



Project Name: _____

Item #: _____

Model #: _____ PHS _____

PHS PORTABLE HAND SINK INSTALLATION MANUAL

For Design and Installation Assistance
Call: 800-221-5644
info@imcteddy.com

50 Ranick Drive East • Amityville, NY 11701
(P) 800-221-5644 • (F) 631-789-3633
www.imcteddy.com

TABLE OF CONTENTS

- Introduction.....1
- Parts & Components Included.....1-2
- Start-Up Procedures.....2-5
- Operation Diagram.....6
- Operation Tips.....6
- Hot Water Warning.....7
- Troubleshooting
 - Handwash System.....7
 - Water Pump.....8
- Warranty & Maintenance.....9



INTRODUCTION

Operating the IMC/Teddy Portable Hand Sink is a straightforward procedure that can be accomplished with normal techniques. Procedures may vary due to field conditions and state regulations. Please note that the following instructions are recommendations only. The operator is responsible for proper setting and making sure the appropriate codes are followed. Please contact the IMC Teddy Engineering Department (800-221-5644) for additional assistance.

Please read the attached information carefully, as much of the information provided is reflecting proven operating techniques used in previous installations.

PARTS & COMPONENTS INCLUDED

- Integral Towel Dispenser (ITD)*
- Electronic Faucet*
- Handwash System*
- Soap Dispenser (SD)*
- 4" Plater Casters, (2) w/ Brakes
- Water Pump*
- Waste Water Tank (6 Gal)*
- Fresh Water Tank (5 Gal)*
- 8' Cord/Plug 5-15/120V*
- Fittings & Hoses
- GFI Outlet*
- Double Outlet Box
- Outlet Cover Plate
- Door Pull*
- Door Lock*
- Hook*
- Door Hinges



* denotes image available



*Integral Towel Dispenser (ITD)



*Electronic Faucet



*Handwash System



*Soap Dispenser (SD)



*Water Pump



*Waste Water Tank (6 Gal)



*Fresh Water Tank (5 Gal)



*8' Cord/Plug 5-15/120 V & Hook



*GFI Outlet



*Door Pull & Lock

START-UP PROCEDURES

Step 1:

Fill fresh water tank with cold, potable water. Fill up to the indicated "Water Level" mark as shown in photo.



Step 2:

Plug the external power cord into a dedicated electrical outlet.



WARNING: The external power cord has a 3 prong standard 5-15 plug. Use only 120V power sources. Please check voltage before operating the unit.

Step 3:

Open cabinet door and plug the following into the GFI outlet:

- a. Water Pump
(standard, black 3 prong plug)
- b. Handwash System
(standard, black 3 prong plug)

**DO NOT RUN THE
PORTABLE HAND SINK
DRY!**

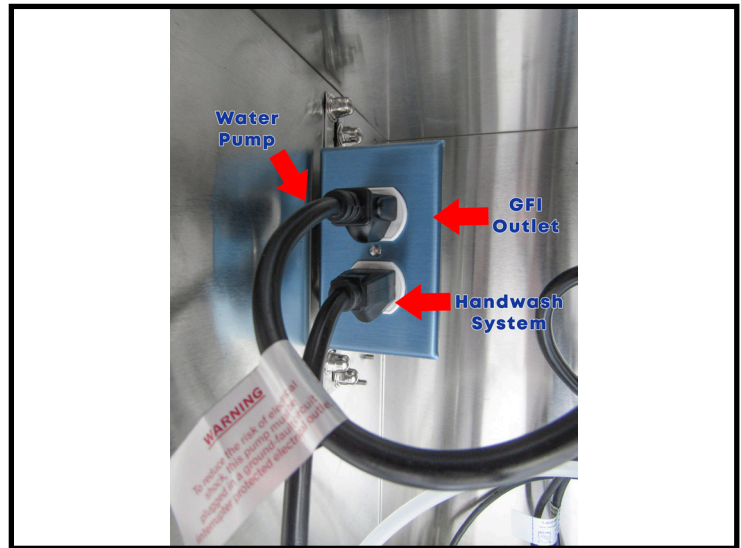

Step 4 (Priming):

With the unit fully connected, place hands under water spout or in front of sensor & let water run 2 minutes.

Make sure hands remain within range of sensor.

If using a manual faucet:

Turn on both the hot & cold levers until water comes out.

Allow 5 minutes for water to heat up.

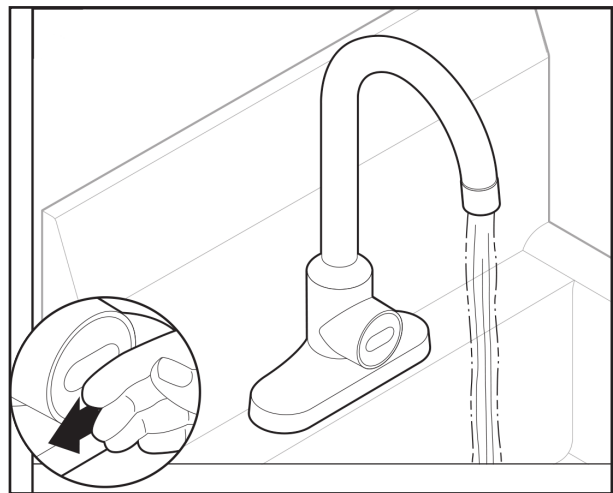

Step 5:

Use a thermometer to check temperature. A temperature setpoint of 100°F (38°C) is recommended.

Temperature should not exceed 105°F (41°C).

**FAILURE TO VERIFY THE
TEMPERATURE MAY CAUSE SCALDING
OR SEVERE INJURY.**

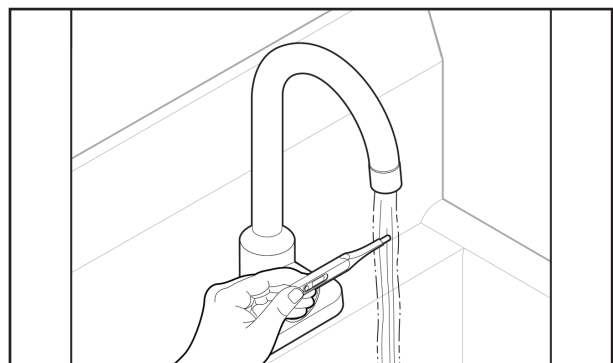

Step 6 (Temperature Calibration):

Remove tank plug & loosen locknut. Turn on fixture & run water for at least 2 minutes to allow water temperature to stabilize.

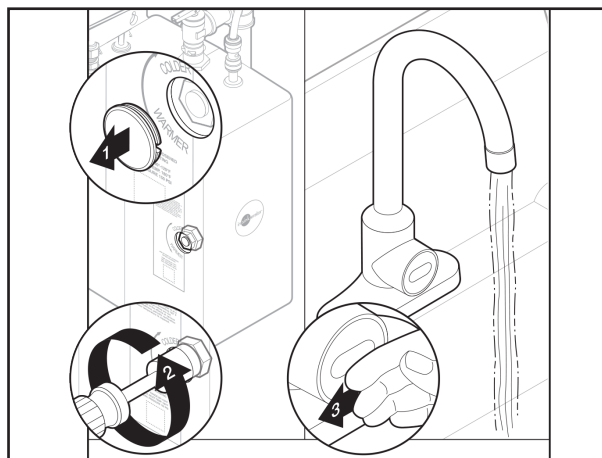

If needed, turn temperature adjustment screw counterclockwise for hotter or clockwise for colder outlet temperature.

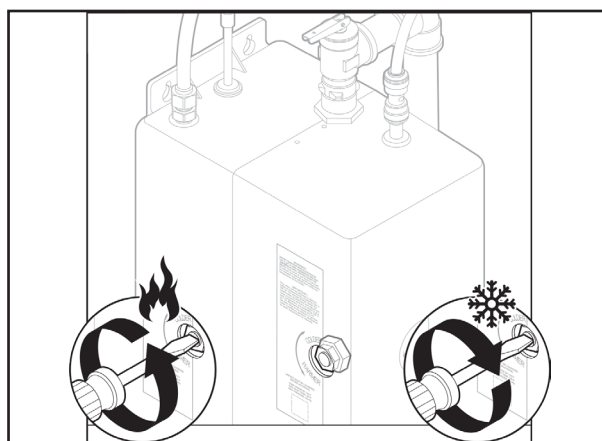

Tighten locknut to prevent accidental or unauthorized temperature adjustment. Replace tank plug. Wait a few minutes for tank to re-heat, and re-check temperature.

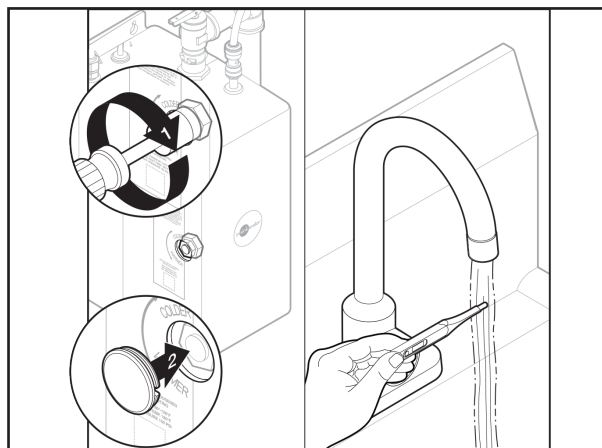

Step 7 (Sensor Calibration - IF NECESSARY):

If the range of the motion sensor is not desirable, press & hold the calibration button on the side of tank (water will run for 8-10 seconds then stop).

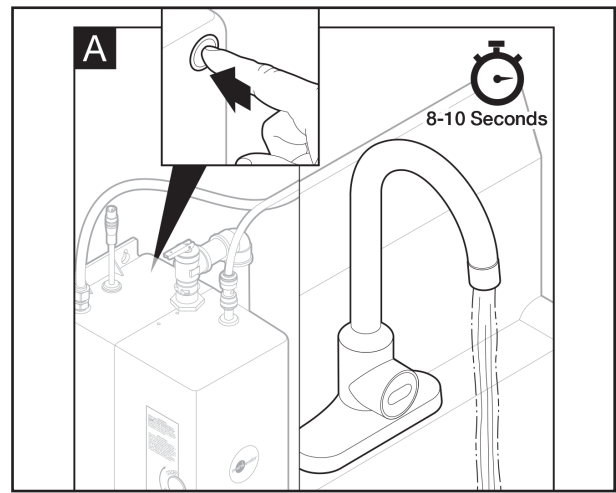

Release button & place a hand in the desired sensor activation location. Wait for 5 seconds until the red LED on the sensor turns off. Test the new activation location by placing a hand in front of the sensor.

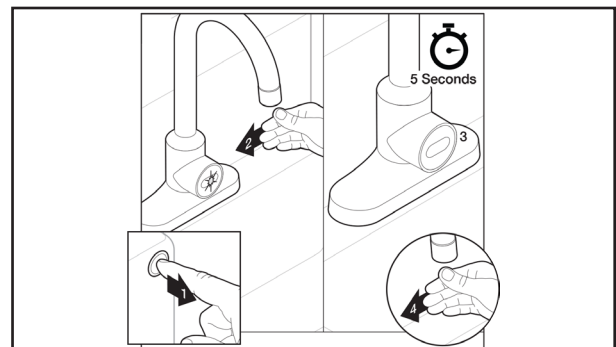

The unit is now ready to use! 

OPERATION DIAGRAM

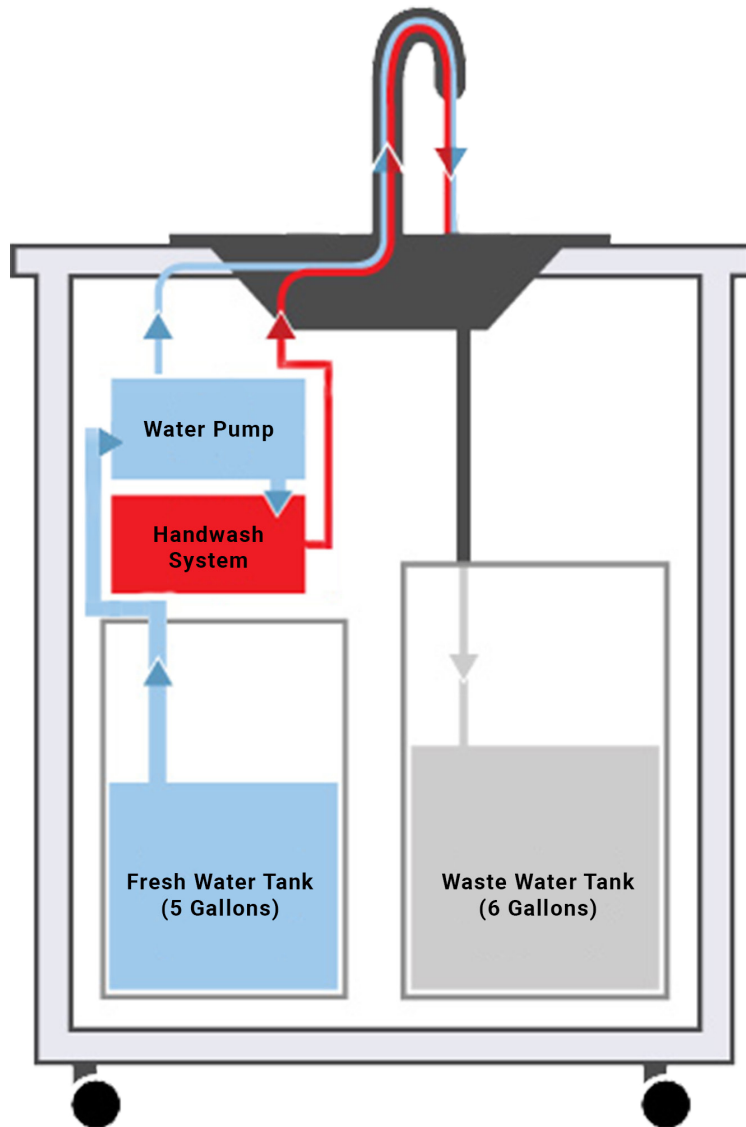

OPERATION TIPS

- Check the waste water tank periodically. Dump out waste water when it reaches the “Empty Water Level”. Dispose of waste water in a sanitary drain only.
- Do **NOT** let the waste water tank overflow.
- Keep the drain hose inserted into the waste water tank at all times.
- Do **NOT** let the water pump run dry for more than 2 minutes; damage to the pump may occur.
- When fresh water tank is empty, the pump will drain air bubbles into the system. This is an indicator that the fresh water tank must be refilled.
- Disconnect the water pump from the GFI outlet until the fresh water tank can be refilled.

⚠ HOT WATER WARNING ⚠

DANGER

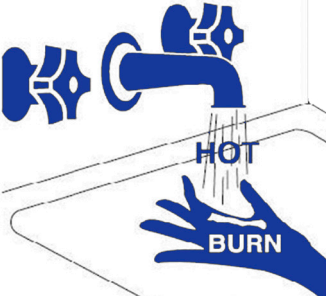

Hot water can be dangerous, especially for infants or children, the elderly, or infirm. There is hot water scald potential if the thermostat is set too high.

Water temperatures over 125°F (51°C) can cause severe burns or scalding resulting in death.

Hot water can cause first degree burns with exposure for as little as:

- 3 seconds at 140° F (60°C)
- 20 seconds at 130° F (54°C)
- 8 minutes at 120° F (48°C)

TROUBLESHOOTING

DO NOT RUN THE PORTABLE HAND SINK DRY!

➔ Handwash System

TEMPERATURE VERIFICATION

This valve can be adjusted to deliver water temperatures exceeding 120°F (49°C). You should always check the outlet water temperature and adjust the valve to ensure delivery of water is at a safe temperature, not exceeding 105°F (41°C). Mechanical valves are not fail-safe. Due to the effects of various water conditions, periodic verification of water temperature is required

Problem	Possible Cause	Solution
Water or steam spits from the T&P valve.	<ul style="list-style-type: none"> Water pressure inside of tank is too high. Temperature inside of tank is too high. T&P valve is faulty. 	<ul style="list-style-type: none"> Reduce incoming water pressure by adding a pressure reducer. Unplug unit, discontinue use and contact us Replace T&P valve.
No warm water.	<ul style="list-style-type: none"> The unit is unplugged. The electric outlet is inoperative. System is in start-up mode. 	<ul style="list-style-type: none"> Make sure the unit is connected to a GFCI outlet. Make sure the circuit breaker or fuses are functioning properly. Check that the outlet is not switched off. Allow system to heat water (there is a 5 minute startup delay before the heater will turn on. The heater will run through the startup process and will take approximately 10 additional minutes for the water to reach temperature).
Water is too hot or not warm enough.	<ul style="list-style-type: none"> TMV is not adjusted to your needs. 	<ul style="list-style-type: none"> Adjust TMV and re-measure output water temperature as described in the Adjusting the Thermostat section on page 4 of this manual.
Undesired output stream.	<ul style="list-style-type: none"> Debris in the end piece. 	<ul style="list-style-type: none"> Unscrew spout end piece and clean out any debris.
Water is dripping from the spout.	<ul style="list-style-type: none"> Debris build up on internal components. 	<ul style="list-style-type: none"> Unplug unit, discontinue use and contact us.
Water discoloration/rusty appearance.	<ul style="list-style-type: none"> Corrosion of unit 	<ul style="list-style-type: none"> Unplug and drain unit. If the water discoloration remains after draining and refilling unit, discontinue use and contact us.
Motion doesn't activate water.	<ul style="list-style-type: none"> Sensor lens is dirty. Unit is not plugged in. Faucet sensor cable is not plugged in. Sensor range. 	<ul style="list-style-type: none"> Clean sensor lens. Make sure the unit is connected. Make sure the circuit breaker or fuses are functioning properly. Check that the outlet is not switched off. Disconnect, inspect, and reconnect sensor cable located on top of tank. Perform sensor calibration steps as described in the Sensor Calibration section on page 5 of this manual.

→ Water Pump

- NEVER remove the ground pin from the power plug.
- If pump runs erratically, open the discharge or dispensing valve. Allow water to circulate, purging any entrapped air. Leave the valve open, disconnect the pump from power and reconnect facilitating the air purging (Stop-start the pump by un-plugging it).
- Once the air is purged the pump will start building pressure, eventually reaching the regulated pressure. Close the valve and the pump should shut off. Check for fitting leaks.
- Observe any leaks after the pump has run for approximately 15 minutes. Further tighten compressions nuts approximately 1/8 to 1/4 of a turn on all fittings in the unit. Wait 15 minutes and repeat the leak check.
- **NOTE: Further adjustments should not be necessary although it may take several days of operation before all the air has been purged and the system is fully stabilized.**
- **Cycling:** In response to the characteristics of the system in which the pump is installed (the flexibility and length of tubing, etc.), the pump may cycle a few times after shut off. **This is normal.** When cycling, the pump should do so at a very low speed.
- Pump will prime **only** if all pressure is relieved from outlet port.

Water Pump Servicing

Every Year - Check unit against operating standards.

Every 5 Years - Replace diaphragm and check against operating standards.

Warranty:

Product is guaranteed against defect in workmanship and material for a period of one year from date of shipment, provided such defects are do not result from abuse, unreasonable usage or other conditions beyond IMC's control. IMC's liability shall not exceed the cost of material furnished.

Easy Cleaning Instructions:

Rinsing is the most important part of care. Stainless steel will retain its original bright appearance if the product is rinsed thoroughly after each use. "Thorough" rinsing can be done by running the water throughout the product for a few minutes after each use. Typically, a rinse and towel drying after each use takes care of most everyday cleanups. For everyday cleaning we recommend using Stainless Steel Cleaners + Polishers. The non-abrasive formula is safe and effective for day to day cleaning. Your product will shine like new!

Recommendations for Proper Maintenance:

Use only a mild liquid dish-washing detergent with a soft sponge to clean and then thoroughly rinse the product. Rinse thoroughly after each use. "Thorough" rinsing can be done by running water for a few minutes and rubbing the cleaned area with a sponge.

Towel dry after each use to prevent mineral deposits from building up on the surface of the product.

- Do Not** allow liquid soap or other household cleansers to dry on the surface. Most brands contain chemical additives which will affect the original finish.

- Do Not** use solutions of chlorine bleach and water. Chlorides, which are found in most soaps, detergents, bleaches, and cleansers, are very aggressive to stainless steel. If left on the surface too long they can cause surface pitting.

- Do Not** use a steel wool pad to clean. Steel wool pads have a tendency to break apart and small particles of steel can become embedded in the surface of the product. The steel particles will rust and will give the appearance that the product itself is rusting.

- Do Not** use abrasive cleansers or abrasive pads as it will scratch the surface.

- Do Not** leave wet sponges, cloths, or cleaning pads on the product. This can lead to surface rust. Following these recommendations for the care and cleaning of your stainless steel product will insure that it will provide you with many years of service.

Chlorides:

Today, chlorides are found in most all soap, detergents, bleaches and cleansers; chlorides can be oppressive to stainless steel. However, chlorides are very water soluble. Therefore, THOROUGH RINSING of your product after each use to remove any chloride residue and a weekly scouring is all that is required to keep your product looking bright and shiny.

Water Quality:

The quality of your water can affect your product's appearance. If your water has a high iron content, a brown surface stain can form on the product giving the appearance of rust. Additionally, in areas with a high concentration of minerals, or with over-softened water, a white film may develop on the product. To combat these problems, we suggest that the product be towel dried after use.

Discoloration, Rust and Possible Pitting:

Wet sponges, cloths, cleaning pads and rubber mats left on the product can lead to discoloration. Steel wool pads should never be used to clean your product as they leave small iron particles in the grain lines which rust and can damage the product. Continued usage in this manner may eventually lead to the product itself rusting and pitting.

Liquid Soap:

Do not allow concentrated liquid detergent to dry on your product. Most brands contain chemical additives which will affect the original finish.

Spotting:

The quality of your water can affect your product's appearance. In areas with hard water, a brown surface stain can form on the product giving the appearance of rust. This also occurs in water with high iron content. Additionally, in areas with a high concentration of minerals, or with over-softened water, a white film may develop on the product. To combat this problem, we suggest that the product be towel dried after use.

Foods:

Heavy salt concentration or foods containing high levels of salt should not be allowed to dry onto the surface. Rinse your product thoroughly after use.

For more in-depth maintenance & care guidelines, visit these resources:

[IMC/Teddy Tips](#)

[NAFEM Tips](#)