

W8 M EASY TOUCH

Vacuum pack machines



- Practical and intuitive EASY TOUCH control with Wifi
- Electronic control system with pressure sensor for fast and precise processing
- Adjustable automatic vacuum percentage: 50-100%
- Dedicated programs for liquids and marinating
- 10 different settings savable to preference
- 6 selectable languages
- Display of vacuum percentage and time to countdown
- Scheduled management of maintenance operations to ensure longer-lasting life oil and filter change warning light
- Thermal pump guard
- Built-in Wi-Fi card which allows careful management of after-sales service at a distance
- Fully manageable via APP that is easy and intuitive and can be downloaded free-of-charge from official stores

Optionals:
External vacuum
Seal bar with Cut-Off Wire

Specifications

Plug & Cord: NEMA 5-20 P



Easy access for oil change and service



mod. W8 30 - 40
Optional Seal bar with Cut-Off Wire



Standard support for vacuum bags with liquids

Optional - External vacuum: hose + GN container + lid



Reinforced Gastronorm Containers and s/steel Lids



Reinforced Gastronorm Containers and Lids

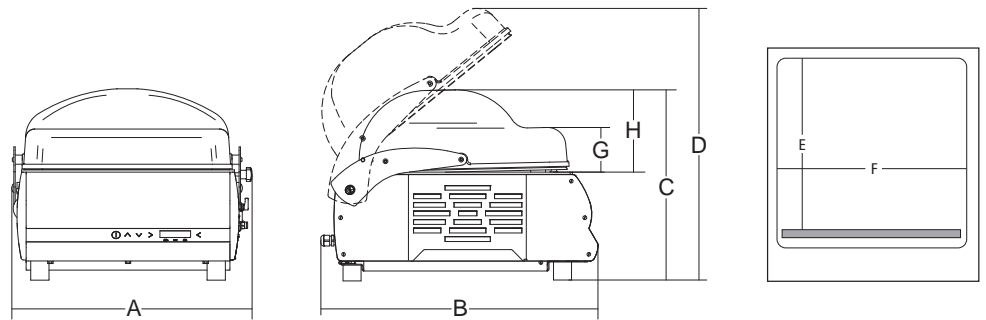

	Electrical	Seal bar	Pump	Chamber dimensions	Chamber dimensions								Net weight	Shipping	Gross weight
					A	B	C	D	E	F	G	H			
		inch.	m3/h	inch.	inch.	inch.	inch.	inch.	inch.	inch.	inch.	inch.	lbs.	inch.	lbs.
W8 M 30 Easy Touch DX	120V, 11.3 A, 1250W	12 ^{1/4} "	9	13 ^{3/8} "x14 ^{3/16} "x6 ^{3/4} "	16"	20 ^{3/4} "	16"	23 ^{1/8} "	13 ^{1/8} "	13 ^{1/8} "	3 ^{47/64} "	6 ^{11/16} "	83	29"x23"x31"	105
W8 M 40 Easy Touch DX	120V, 8.7 A, 1150W	16 ^{1/8} "	14	17"x16 ^{1/8} "x7 ^{1/8} "	19 ^{1/2} "	23"	16 ^{5/8} "	24 ^{3/4} "	15 ^{3/8} "	17"	3 ^{47/64} "	7 ^{3/32} "	123	30"x26"x31"	145