



Drago America
www.dragoamerica.com

Project Name: _____

Location: _____

Item #: _____ Qty: _____

Model #: _____

SIA #

AIA #

Model:
DRSP36-10

Prep Tables – Sandwich Prep Table

2 solid doors 9 ft³



Features & Benefits

Strong & Durable Structure

- Stainless steel interior and exterior, aluminum back.

Temperature

- Temperature range 33°F~40°F (0°C~4°C).

User Friendly Features

- Self-closing doors with 90 degree stay-open feature.
- Adjustable heavy duty PVC coated shelves.
- Easy access to condenser coil for cleaning and service.
- Easy adjust temperature set point and defrost frequency.

Pre-installed heavy-duty casters with brakes.

Refrigerant R290.



Certifications



Intertek



Intertek

Doors	Shelves	Pans	Pans Size	HP	AMPS	Crated Weight	Dimensions (inches)		
							W	D	H
2	2	10	1/6	1/2	4.3	247 lb (112 Kg)	36.2" (920 mm)	29.5" (750 mm)	41.5" (1055 mm)

Packaging dimensions: W 41.3" (1050 mm) x D 34.6" (880 mm) x H 45.5" (1157 mm).

Approvals:	Available At:
------------	---------------

Model:
DRSP36-10

Prep Tables – Sandwich Prep Table

2 solid doors 9 ft³



Plan View

Front View

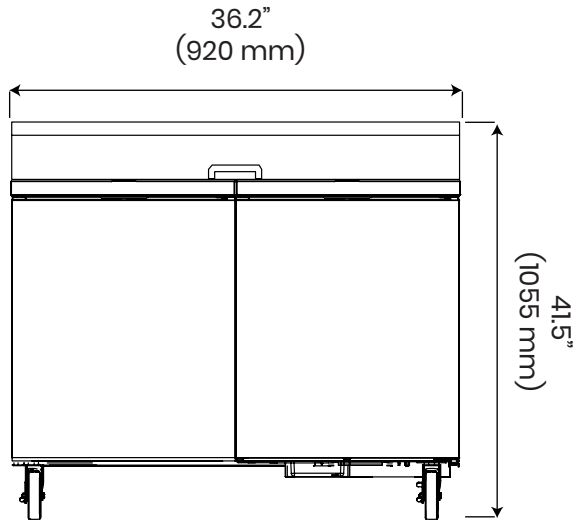

Side View

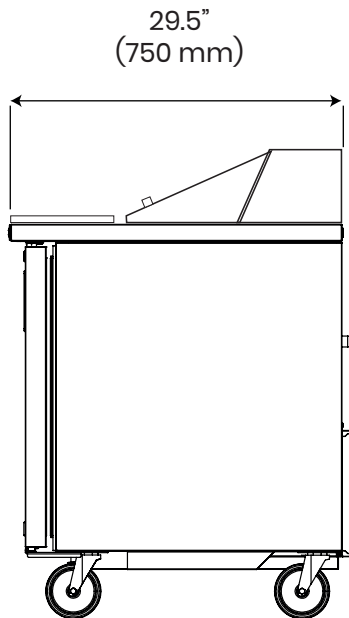

Spec

Electric Data

Voltage	115/60/1
Plug Type	NEMA 5-15P
Compressor HP	1/2
Refrigerant	R290

Dimensional Data

Capacity - cu. ft.	9 ft ³ (258 liters)
Net Weight - Lbs.	220 Lbs. (100 Kg)

- Slight Variations May Exist

DRAGO

Drago America
www.dragoamerica.com
(346) 374-8343
9777 W. Gulf Bank Road Suite 200, Houston, Texas 77040