

DISPLAY UNDERCOUNTER REFRIGERATOR

Model: UC48NGD-B

Natural Refrigerant R-290 Model

48" Undercounter Front Breathing Refrigerator with Glass Door - Black Enamel Finish

Textured baked black enamel finish exterior. Stainless steel top, aluminum interior



Options and Accessories

(upcharge and lead times may apply)

Stainless steel interior

Additional epoxy coated steel shelves

Consult factory for other model configurations, options and accessories.

Continental
Refrigerator



Project Name:

Model Specified:

Location:

Item No:

Quantity:

AIA #:

SIS #:

Standard Model Features

REFRIGERATION SYSTEM

Performance-rated front breathing refrigeration system

Natural, environmentally safe, high efficiency R-290 refrigerant¹

Automatic, hot gas condensate evaporator

Non-corrosive, plasticized fin evaporator coil

Easily serviceable slide out condensing unit

CABINET ARCHITECTURE

2" non-CFC polyurethane foam insulation

Spring loaded, self closing glass door with cylinder lock

Magnetic snap in Santoprene™ door gasket

Heavy duty, epoxy coated steel shelves

5" casters

MODEL FEATURES

Easily accessible and serviceable condensing unit

Electronic control, off-cycle defrost

¹ R-290 refrigerant meets all federal and state regulatory requirements.

APPROVAL:

Model Specifications

DIMENSIONAL DATA

Net Capacity (cubic feet)	9 (255 l)
Width, Overall (inches)	48 (1219 mm)
Depth, Overall (inches) (including handle & bumpers)	32 (813 mm)
Height, Overall (inches) (including 1 3/8" plate casters)	31 7/8 (809.7 mm)
Shelf area (square feet)	4.4 (0.48 sq m)
No. of Shelves	4
No. of Doors	2
Interior Depth (inches)	19 3/4 (502 mm)
Interior Height (inches)	18 (458 mm)
Interior Width (inches)	44 (1118 mm)

REFRIGERANT DATA

Condensing Unit Size (H.P.)	1/5
Capacity (BTU per hour)*	1470

ELECTRICAL DATA

Voltage	115/60/1
Total Amps	2.5
10 ft. Cord/Plug [attached]	Yes

SHIPPING DATA

Weight (pounds)	248 (113 kg)
Height - Crated (inches)	43 1/4 (1099 mm)
Width - Crated (inches)	55 (1397 mm)
Depth - Crated (inches)	37 1/4 (946 mm)

* Rating @ +25°F evaporator, 90°F ambient
 Figures in parentheses reflect metric equivalents rounded to the nearest whole unit.



Equipped with one NEMA-5-15P Plug
 (varies by country)

Model Plan Views

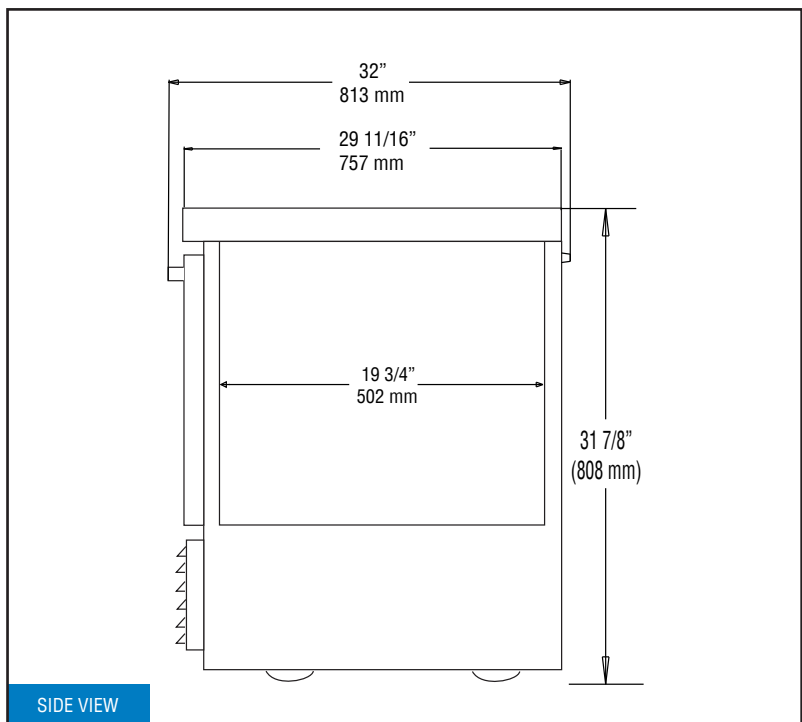
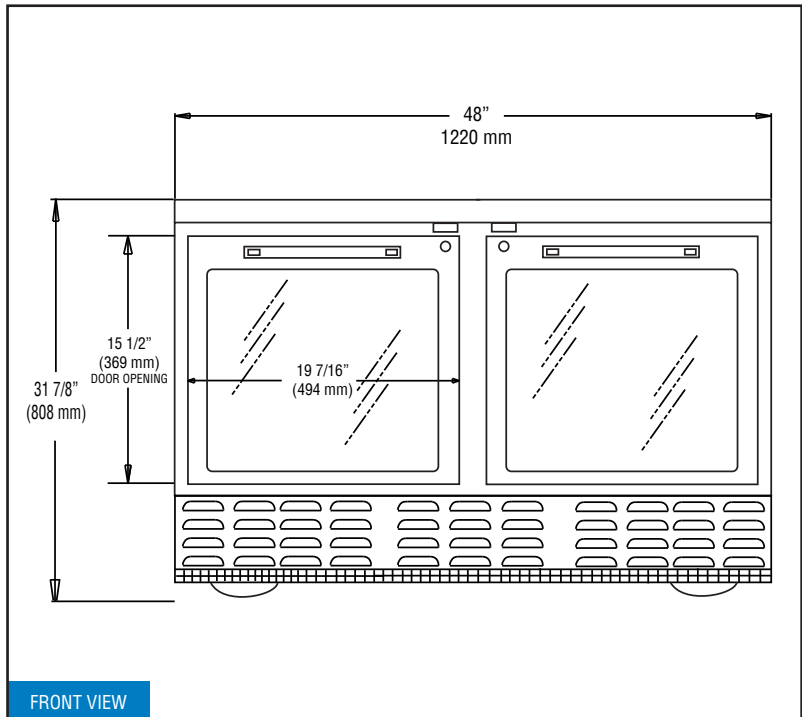

NOTE: For proper operation, the area under and in front of the cabinet **must** not be obstructed in any way.

Continental
 Refrigerator

Toll-Free: 800-523-7138
 Phone: 215-244-1400
 Fax: 215-244-9579

539 Dunksferry Road
 Bensalem, PA 19020
www.continentalrefrigerator.com

Due to our continued efforts in developing innovative products, specifications subject to change without notice.



PROUDLY
 DESIGNED & ASSEMBLED
 IN THE U.S.A.

Intertek

© Copyright 2023. Continental Refrigerator.
 A Division of National Refrigeration & Air Conditioning Products, Inc.