



Drago America  
www.dragoamerica.com

Project Name: \_\_\_\_\_

Location: \_\_\_\_\_

Item #: \_\_\_\_\_ Qty: \_\_\_\_\_

Model #: \_\_\_\_\_

SIA #

AIA #

Model:  
DRWT48F

**Freezers – Worktop Freezer**  
2 solid doors 12 ft<sup>3</sup>



**Features & Benefits**

**Strong & Durable Structure**

- Stainless steel interior and exterior, aluminum back.

**Temperature**

- Temperature range -7°F~0°F (-22°C~-18°C).

**User Friendly Features**

- Self-closing doors with 90 degree stay-open feature.
- Adjustable heavy duty PVC coated shelves.
- Easy access to condenser coil for cleaning and service.
- Easy adjust temperature set point and defrost frequency.

**Pre-installed heavy-duty casters with brakes.**  
**Refrigerant R290.**



**Certifications**



**Intertek**



**Intertek**

Doors	Shelves	HP	AMPS	Crated Weight	Dimensions (inches)		
					W	D	H
2	2	1/2	4.5	302 Lb (137 Kg)	48" (1219.2 mm)	29.5" (750 mm)	38.75" (984.2 mm)

Packaging dimensions inch(mm): W 50" (1270) x D 32" (820) x H 42.1" (1070)

Approvals:

Available At:

Model:  
DRWT48F

## Freezers - Worktop Freezer

2 solid doors 12 ft<sup>3</sup>



Plan View

Front View

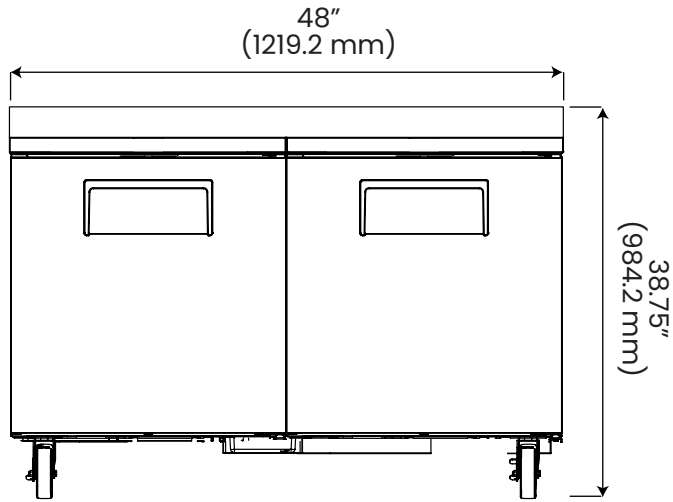

Side View

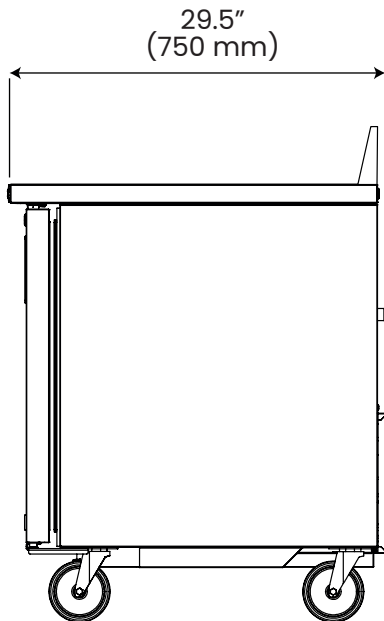

Spec

### Electric Data

Voltage	115/60/1
Plug Type	NEMA 5-15P
Compressor HP	1/2
Refrigerant	R290

### Dimensional Data

Capacity - cu. ft.	12 ft <sup>3</sup> (399.8 liters)
Net Weight - Lbs.	213.4 Lbs. (97 Kg)

# DRAGO

Drago America  
www.dragoamerica.com  
(346) 374-8343  
9777 W. Gulf Bank Road Suite 200, Houston, Texas 77040