



Drago America
www.dragoamerica.com

Project Name: _____

Location: _____

Item #: _____ Qty: _____

Model #: _____

SIA #

AIA #

Model:
DRUC48R

Refrigerators – Undercounter Refrigerator

2 solid doors 12 ft³



DRAGO
REFRIGERATION



Features & Benefits

Strong & Durable Structure

- Stainless steel interior and exterior, aluminum back.

Temperature

- Temperature range 33°F~40°F (0°C~4°C).

User Friendly Features

- Self-closing doors with 90 degree stay-open feature.
- Adjustable heavy duty PVC coated shelves.
- Easy access to condenser coil for cleaning and service.
- Easy adjust temperature set point and defrost frequency.

Pre-installed heavy-duty casters with brakes.
Refrigerant R290.



Certifications



Intertek



Intertek

Doors	Shelves	HP	AMPS	Crated Weight	Dimensions (inches)		
					W	D	H
2	2	1/3	2.4	257.9 Lb (117 Kg)	47.2" (1200 mm)	29.5" (750 mm)	35.2" (895 mm)

Packaging dimensions (mm): W 50" (1270) x D 32" (820) x H 38.6" (980)

Approvals:

Available At:

Model:
DRUC48R

Refrigerators - Undercounter Refrigerator

2 solid doors 12 ft³



Front View

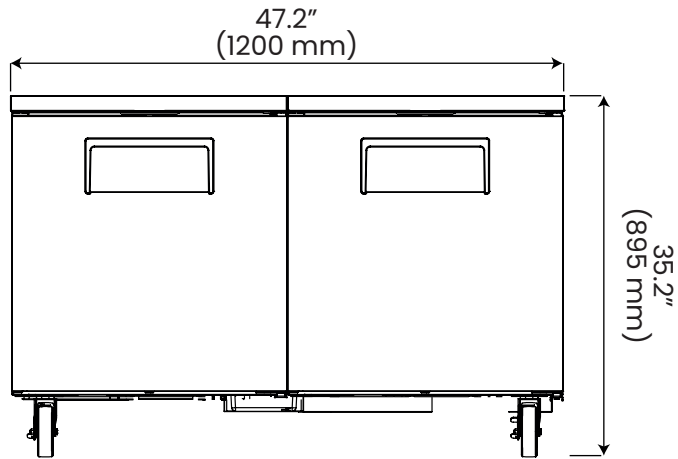

Side View

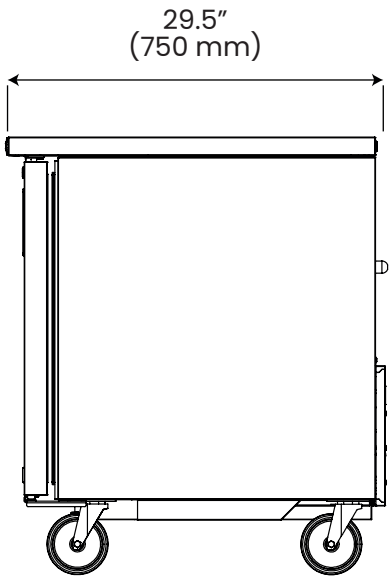

Electric Data	
Voltage	115/60/1
Plug Type	NEMA 5-15P
Compressor HP	1/3
Refrigerant	R290

Dimensional Data	
Capacity - cu. ft.	12 ft ³ (339.8 liters)
Net Weight - Lbs.	213.4 Lbs. (97 Kg)



Drago America
www.dragoamerica.com
(346) 374-8343
9777 W. Gulf Bank Road Suite 200, Houston, Texas 77040