

# UNDERCOUNTER REFRIGERATOR

## Model: UC48SN-B

Natural Refrigerant R-290 Model

48" Undercounter Front Breathing Refrigerator with Solid Door-Shallow Depth, Black Enamel Finish

Textured baked black enamel finish exterior. Stainless steel top. Aluminum interior



ENERGY STAR® Qualified Commercial Refrigerator

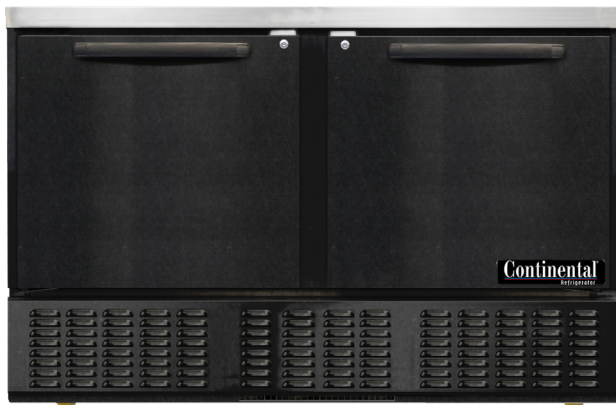

## Options and Accessories

(upcharge and lead times may apply)

Stainless steel interior	Additional epoxy coated steel shelves
Glass door	

Consult factory for other model configurations, options and accessories.



Project Name:

Model Specified:

Location:

Item No: Quantity:

AIA #: SIS #:

## Standard Model Features

### REFRIGERATION SYSTEM

Performance-rated front breathing refrigeration system

Natural, environmentally safe, high efficiency R-290 refrigerant<sup>1</sup>

Automatic, hot gas condensate evaporator

Non-corrosive, plasticized fin evaporator coil

Easily serviceable slide out condensing unit

### CABINET ARCHITECTURE

2" non-CFC polyurethane foam insulation

Spring loaded, self closing door with cylinder lock

Magnetic snap in Santoprene™ door gasket

Heavy duty, epoxy coated steel shelves

5" casters

### MODEL FEATURES

Cabinet field rehingeable

Easily accessible and serviceable condensing unit

Electronic control, off-cycle defrost

<sup>1</sup> R-290 refrigerant meets all federal and state regulatory requirements.

APPROVAL:

# Model Specifications

## DIMENSIONAL DATA

Net Capacity (cubic feet)	7.0 (198 l)
Width, Overall (inches)	48 (1219 mm)
Depth, Overall (inches) (including handle & bumpers)	27 5/8 (702 mm)
Height, Overall (inches) (including 1 3/8" plate casters)	31 7/8 (809.7 mm)
Shelf area (square feet)	4.4 (0.48 sq m)
No. of Shelves	4
No. of Doors	2
Interior Depth (inches)	15 3/8 (391 mm)
Interior Height (inches)	18 (458 mm)
Interior Width (inches)	44 (1118 mm)

## REFRIGERANT DATA

Condensing Unit Size (H.P.)	1/5
Capacity (BTU per hour)*	1470

## ELECTRICAL DATA

Voltage	115/60/1
Total Amps	2.5
10 ft. Cord/Plug [attached]	Yes

## SHIPPING DATA

Weight (pounds)	248 (113 kg)
Height - Crated (inches)	43 1/4 (1099 mm)
Width - Crated (inches)	55 (1397 mm)
Depth - Crated (inches)	37 1/4 (946 mm)

\* Rating @ +25°F evaporator, 90°F ambient  
 Figures in parentheses reflect metric equivalents rounded to the nearest whole unit.



Equipped with one NEMA-5-15P Plug  
 (varies by country)

# Model Plan Views

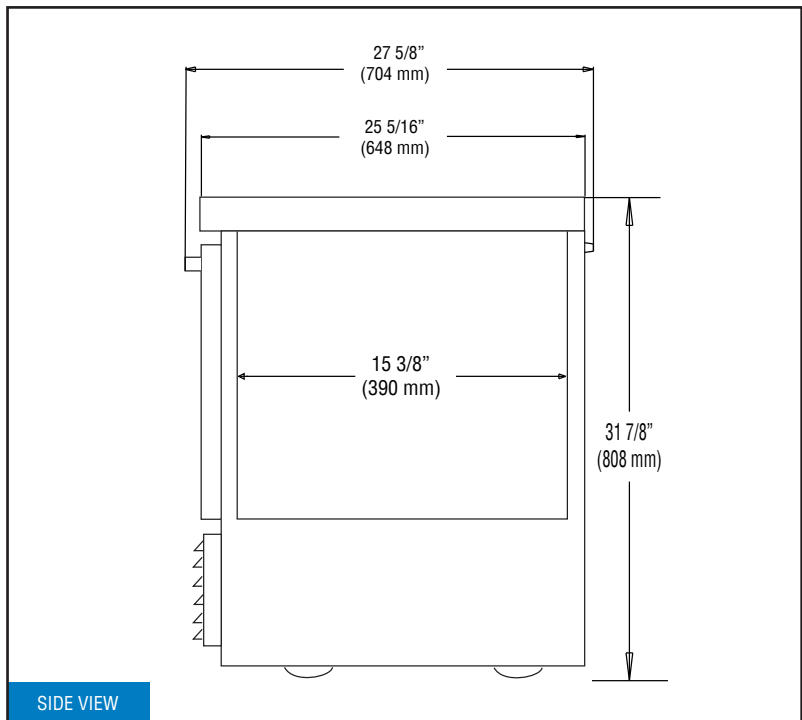
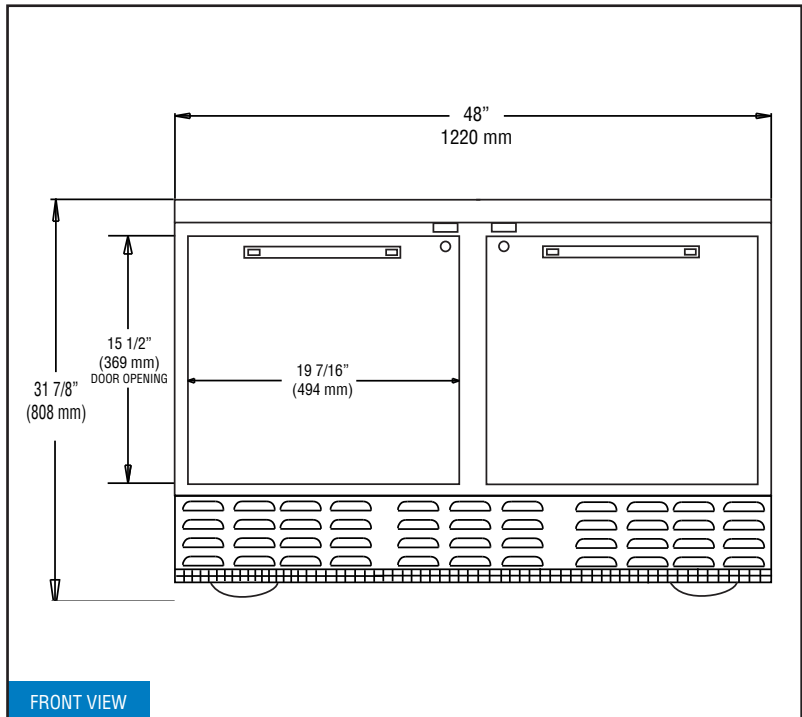

**NOTE:** For proper operation, the area under and in front of the cabinet **must** not be obstructed in any way.



Toll-Free: 800-523-7138  
 Phone: 215-244-1400  
 Fax: 215-244-9579

539 Dunksferry Road  
 Bensalem, PA 19020  
[www.continentalrefrigerator.com](http://www.continentalrefrigerator.com)

Due to our continued efforts in developing innovative products, specifications subject to change without notice.



PROUDLY  
 DESIGNED & ASSEMBLED  
 IN THE U.S.A.

**Intertek**

© Copyright 2023. Continental Refrigerator.  
 A Division of National Refrigeration & Air Conditioning Products, Inc.

REVISED 6/27/25