



Drago America
www.dragoamerica.com

Project Name: _____

Location: _____

Item #: _____ Qty: _____

Model #: _____

SIA #

AIA #

Model:
DRCB48

Chef Base
8 ft³



**DRAGO
REFRIGERATION**



Features & Benefits

Strong & Durable Structure

- Stainless steel interior and exterior.
- Matching aluminium finished back.

Temperature

- Temperature range 33°F ~ 40°F (0°C ~ 4°C).

User Friendly Features

- Preinstalled heavy-duty casters.
- Heavy-duty pull handles.
- Electronic control system; easy adjust temperature set point and defrost frequency.
- Easy access to condenser coil for cleaning and service.

Refrigerant R290.



Certifications



Intertek



Intertek

Drawers	HP	AMPS	Crated Weight	Dimensions (inches)		
				W	D	H
2	1/3	4.32	256 Lbs (116 Kg)	48.3" (1226.8 mm)	32.1" (815.3 mm)	25.4" (645.1 mm)

Packaging dimensions (mm): W 51" (1294) x D 34.6" (880) x H 21.6" (550)

Approvals:

Available At:

Model:
DRCB48

Chef Base
8 ft³



Front View

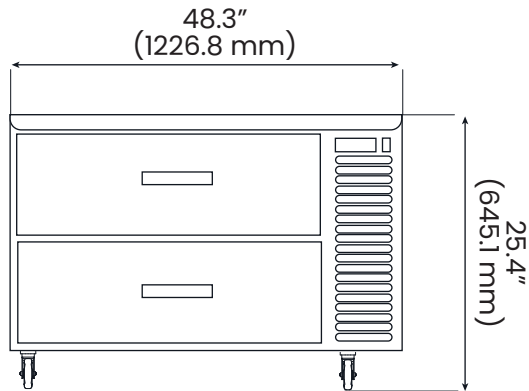

Electric Data

Voltage	115/60/1
Plug Type	NEMA 5-15P
Compressor HP	1/3
Refrigerant	R290

Dimensional Data

Capacity - cu. ft.	8 ft ³ (226.5 liters)
Net Weight - Lbs.	202 Lbs (92 Kg)

Side View

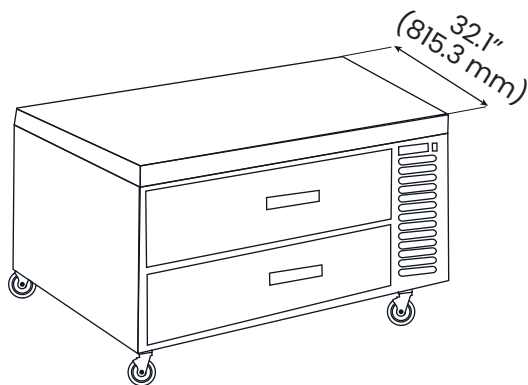

Drago America
www.dragoamerica.com
(346) 374-8343
9777 W. Gulf Bank Road Suite 200, Houston, Texas 77040