

USER'S MANUAL

CAKE DISPLAY

Model: DRCD36-2, DRCD36-3, DRCD48-2, DRCD48-3
DRCD60-2, DRCD60-3, DRCD72-2, DRCD72-3

**PLEASE READ THE MANUAL THOROUGHLY PRIOR TO
EQUIPMENT SET-UP, OPERATION AND MAINTENANCE**

TABLE OF CONTENTS

◆ CAUTION FOR SAFETY	1
◆ INSTALLATION.....	2
Cabinet location and installation guidelines.....	2
Electrical safety	5
◆ OPERATION	5
◆ REGULAR MAINTENANCE.....	6
Cleaning the condenser coil.....	6
Cleaning the fan blade and motor.....	7
Cleaning the interior of unit.....	7
◆ TROUBLE SHOOTING.....	8

**IMPORTANT SAFETY INSTRUCTIONS, READ CAREFULLY
AND KEEP FOR FUTURE REFERENCE**

CAUTION FOR SAFETY

1. Leave enough space from the wall to the cabinet and the ceiling: do not be sealed completely in the back part of the cabinet. Prepare an air vent to the outside.

Caution: It needs more than 20 cm from the cabinet to wall

2. Please move away all out-package for bottom heat radiation to avoid fire.
3. It's prohibited to store flammable and volatile chemical, or leading to exploding.
4. Individual single-phase socket must be used. It should be reliably connected to a grounding wire

Caution: Do not connect grounding wire to a water or gas pipe

5. Do not be hard collided or fiercely vibrated when in transportation, it is not larger than 45 for the inclination of the cabinet.
6. Please refer to the Trouble shooting references when the unit is facing some problems. Do not attempt to solve the problem on your own. Please refer to certified technician only.
7. **DANGER-** Risk of fire or explosion. Flammable refrigerant used. Do not use mechanical devices to defrost refrigerator. Do not puncture refrigerant tubing.

DANGER- Risk of fire of explosion. Flammable refrigerant used. To be repaired only by trained service personnel. Do not puncture refrigerant tubing.

CAUTION- Risk of fire or explosion. Flammable refrigerant used.

Consult repair manual/owner's guide before attempting to service this product. All safety precautions must be followed.

CAUTION- Risk of fire or explosion. Dispose of properly in accordance with federal or local regulations. Flammable refrigerant used.

CAUTION- Risk of fire or explosion due to puncture of refrigerant tubing: follow handling instructions carefully. Flammable refrigerant used.

CAUTION-Keep clear of obstruction all ventilation openings in the appliance enclosure or in the structure for building-in.

CAUTION- servicing shall be done by factory authorized service personnel, so as to minimize the risk of possible ignition due to incorrect parts or improper service.

INSTALLATION

IMPORTANT! PLEASE READ BEFORE INSTALLATION

- If the unit has recently been transported. Please let unit stand still for a minimum of 24 hours before plugging it in.
- Make sure that there is proper ventilation around the unit in the where it will operate.
- Make sure all accessories are installed before plugging the unit in.
- Please read through the manual in its entirety.

CABINET LOCATION AND INSTALLATION GUIDELINES

■ Unpacking

The unit is delivered on a pallet and crated. Documentation is inserted into a clear pocket located inside the unit. Carefully uncrate the unit and remove cardboard from the unit exterior and from the door opening surround making sure that any sharp instrument used does not cause damage.

■ Install the unit on strong and leveled surfaces

- unit may make unpleasant noises if surface is uneven
- unit may malfunction if surface is uneven
- If the floor is not flat, please use something to make sure the base of this unit in horizontal level

■ Install the unit in an indoor, well-ventilated area

- unit performs more efficiently in a well-ventilated area
- for best performance, please maintain clearance of 100mm / 4" on the back of the unit, 50mm / 2" on the top of the unit
- outdoor use may cause decrease efficiency and damage to the unit

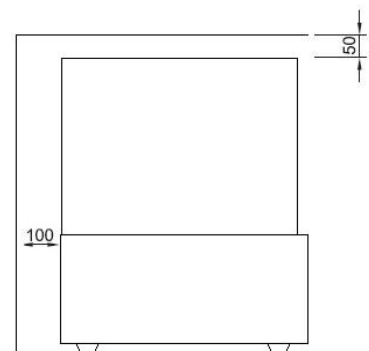

■ Avoid installation in a high humidity and / or dusty area

- humidity could cause unit to rust and decrease efficiency of the unit
- dust collected on condenser coil will cause unit to malfunction. Clean the condenser at least once a month with a brush or clean cloth

■ Select a location away from heat and moisture-generating equipment

- high ambient temperature will cause the compressor to overwork, leading to higher energy

bills and gradual breakdown of the unit

■ **The appliance shall not be exposed to rain, sun**

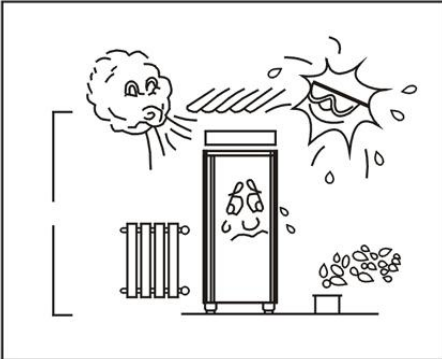

! *The cabinet must not be located in a chloride / acid-containing environment (swimming-bath etc.) due to risk of corrosion.*

CAUTION: PROBLEMS CAUSED BY UNPROPER POSITION OF UNITS ARE NOT COVERED BY WARRANTY

■ **Shelving installation**

1. Remove both sliding rear doors by lifting each door up and pulling out at the bottom.



2. Install left and right shelf brackets teeth end into stainless pilasters, adjust to desired height matching right.



3. Hang front and rear shelf support panels to the left and right shelf brackets, screw them on both left and right sides.

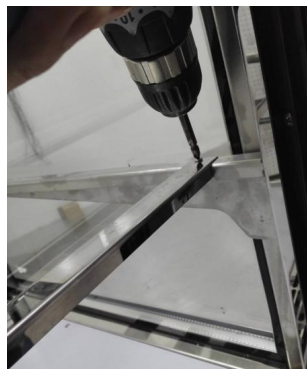
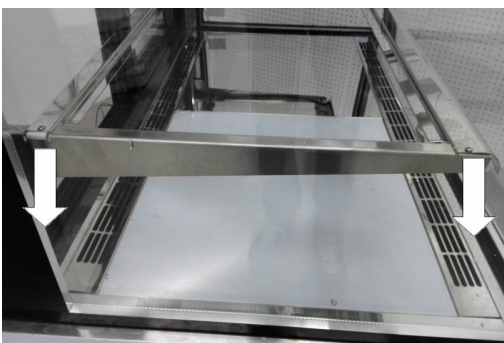

4. Plug light to the socket on stainless pilasters

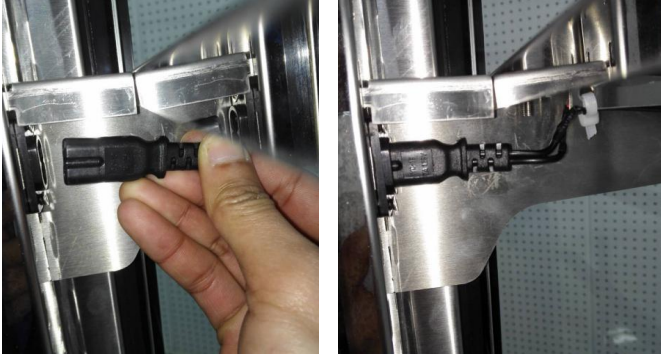

5. Position glass shelves

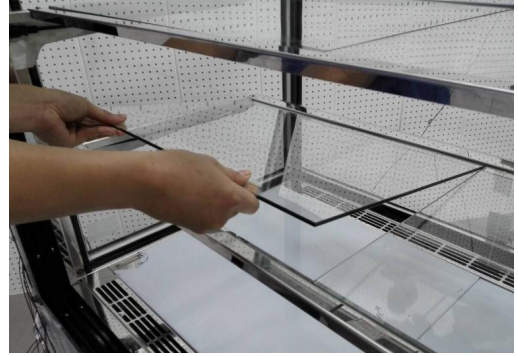

6. Refit the sliding doors by lifting each door up into the top track and placing onto the bottom track.



■ Locking castor

After positioning the cabinet, castors (wheels) should be locked to prevent the cabinet from moving. The unit was installed with castors and adjustable feet, the adjustable feet are for locking the castor, adjust them to touch floor.

Adjust the feet to touch floor

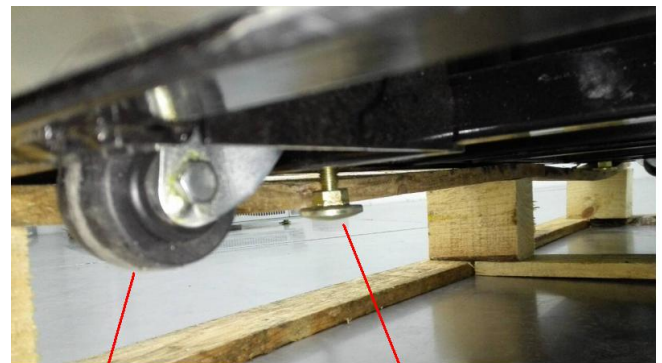
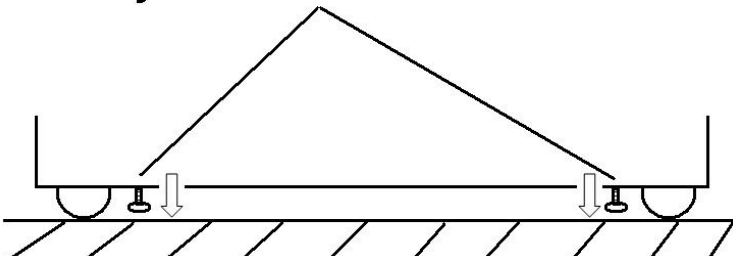

Castor

Adjustable foot

- Please ensure that the required voltage of the compressor is being supplied at all times
CAUTION: Low or high voltage can detrimentally affect the refrigeration unit.
- All units should be plugged into a grounded and properly-sized electrical outlet with appropriate overcurrent protection. Please refer to the electrical requirement on the nameplate.

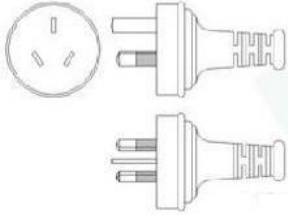

If you do not have the right outlet have a certified electrician install the correct power source.



To minimize shock and fire hazards, be sure not to overload outlet. Please designate one outlet for your unit., make sure that the unit is properly grounded.

- Please make sure that your unit has its own dedicated outlet. Do not use an extension cord.



- When the unit is not in use for a long period of time, please unplug the unit from the outlet.
- After unplugging the unit, wait at least 10 minutes before re-plugging it. Failure to do so could cause damage to the compressor.
- Do not attempt to alter or tamper with the electrical cord.

OPERATION

■ Start up

Plug the cabinet into the power supply and check operation of the refrigeration unit, cabinet lighting and electronic controller.

The compressor and condenser fans should all operate within two minutes from the time the cabinet is plugged in. This may be verified by listening for compressor switch on and checking for air movement out of the air vent slots around the bottom of the glass. The compressor and condenser fans should switch off and on, depending on the cabinet temperature.

■ Loading products

Attention: Make sure that the unit drops down to desired temperature before loading the unit with food

- Allow air space around all the product, to ensure even cooling and efficient operation of the chiller.

- Leave an airspace of at least 75mm above product loaded on the top shelf.
- Do not allow products to overhang the rear of the shelves as this could prevent the sliding doors from shutting properly.
- Do not exceed a maximum loading of 20kg per shelf.
- Remove some product if the shelves are flexing or bending.

■ Operation instruction for temperature controller

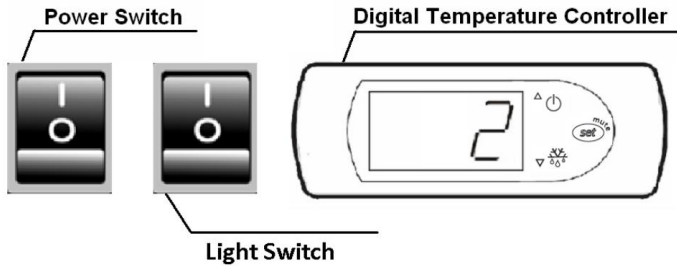

To display or set the set point, proceed as follow:

- 1) press **SET** for 1s, the set value will start flashing after a few moments;
- 2) increase or decrease the value using **UP** or **DOWN**;
- 3) press the **SET** button again to confirm the new value.

REGULAR MAINTENANCE



Before maintenance and cleaning, please unplug the unit, do not plug or unplug the cord with wet hands.

CLEANING THE CONDENSER COIL

- For efficient operation, it is important that the condenser surface be kept free of dust, dirt, and lint.
- We recommend cleaning the condenser coil and fins at least once per month.
- Clean with a commercial condenser coil cleaner, available from any kitchen equipment retailer. Brush the condenser fins from top to bottom, not side to side.
- After cleaning, straighten any bent condenser fins with a fin comb.

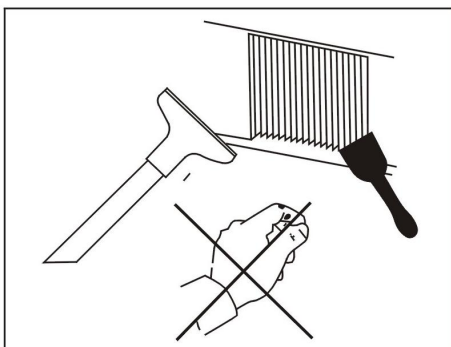

CLEANING THE FAN BLADE AND MOTOR

If necessary, clean the fan blades and motor with a soft cloth, if it is necessary to wash the fan blades, cover the fan motor to prevent moisture damage.

CLEANING THE INTERIOR OF UNIT

- When cleaning the cabinet interior ,use a solvent of warm water and mild soap.
- Do not use steel wool, caustic soap, abrasive cleaners, or bleach that may damage the stainless steel surface.
- Wash door gaskets on a regular basis, preferably weekly. Simply remove door gasket from the frame of the door, soak in warm water and soap for thirty (30) minutes, dry with soft cloth, and replace.
- Check door gaskets for proper seal after they are replaced.
- Periodically remove the shelves and pilasters from the unit and clean them with mild soap and warm water. To remove the pilasters, first remove the shelves and shelf brackets. Then, simply lift the pilaster up and out.

WARNING

Disconnect power cord before cleaning any parts of the unit.

TROUBLE SHOOTING

Before requesting any service on your unit, please check the following points.

Please note that this guide serve only as a reference for solutions to common problems.

SYMPTOM	POSSIBLE CAUSE	CORRECTIVE ACTION
Compressor not running.	Fuse blown or circuit breaker tripped. Power cord unplugged. Thermostat set too high. Cabinet in defrost cycle.	Replace fuse or reset circuit breaker. Plug in power cord. Set thermostat to lower temperature. Wait for defrost cycle to finish.
Condensing unit runs for long periods of time.	Excessive amount fo warm product placed in cabinet. Prolonged door opening or door ajar. Door gasket(s) not sealing properly. Dirty condenser coil. Evaporator coil iced over.	Allow adequate time for product to cool down. Ensure doors are closed when not in use. Avoid opening doors for long periods of time. Ensure gaskets are snapped in completely. Remove gasket and wash with soap and water. Check condition of gasket and Replace if necessary. Clean the condenser coil. Unplug unit and allow coil to defrost. Make sure thermostat is not set too cold. Ensure that door gasket(s) are sealing properly.
Cabinet temperature is too warm.	Thermostat set too warm. Blocking are flow. Excessive amount of warm product placed in cabinet. Fuse blown or circuit breaker tripped. Dirty condenser coil. Prolonged door opening or door ajar. Evaporator coil iced over.	Set thermostat to lower temperature. Re-arrange product to allow for Proper air flow. Make sure there is at least four inches of clearance from evaporator. Allow adequate time for product to cool down. Replace fuse or reset circuit breaker. Clean the condenser coil. Ensure doors are closed when not in use. Avoid opening doors for long periods of time. (see above)
Cabinet is noisy.	Loose part(s). Tubing vibration.	Locate and tighten loose part(s). Ensure tubing is free from contact with other tubing or components.