



Drago America
www.dragoamerica.com

Project Name: _____

Location: _____

Item #: _____ Qty: _____

Model #: _____

SIA #

AIA #

Model:
DRSP60-16

Prep Tables – Sandwich Prep Table

2 solid doors 15 ft³



Features & Benefits

Strong & Durable Structure

- Stainless steel interior and exterior, aluminum back.

Temperature

- Temperature range 33°F~40°F (0°C~4°C).

User Friendly Features

- Self-closing doors with 90 degree stay-open feature.
- Adjustable heavy duty PVC coated shelves.
- Easy access to condenser coil for cleaning and service.
- Easy adjust temperature set point and defrost frequency.

Pre-installed heavy-duty casters with brakes.

Refrigerant R290.



Certifications



Intertek



Intertek

Doors	Shelves	Pans	Pans Size	HP	AMPS	Crated Weight	Dimensions (inches)		
							W	D	H
2	2	16	1/6	1/2	5.4	328.5 Lb (149 Kg)	60.2" (1529 mm)	29.5" (750 mm)	42.4" (1076.9 mm)

Packaging dimensions: W 65.3" (1660 mm) x D 34.6" (880 mm) x H 45.5" (1157 mm).

Approvals:

Available At:

Model:
DRSP60-16

Prep Tables – Sandwich Prep Table

2 solid doors 15 ft³



Front View

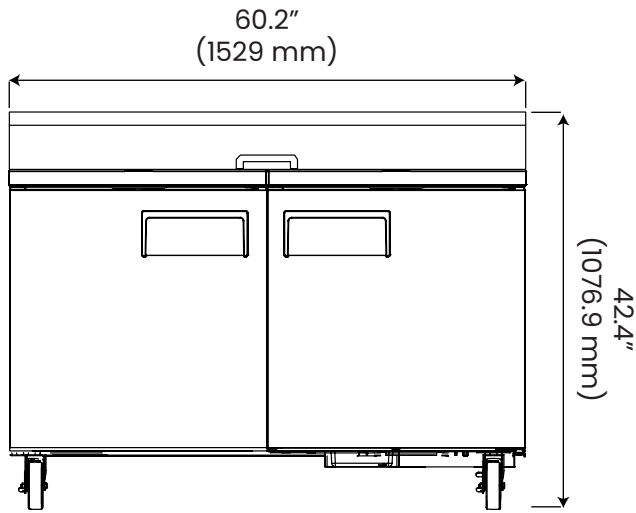

Side View

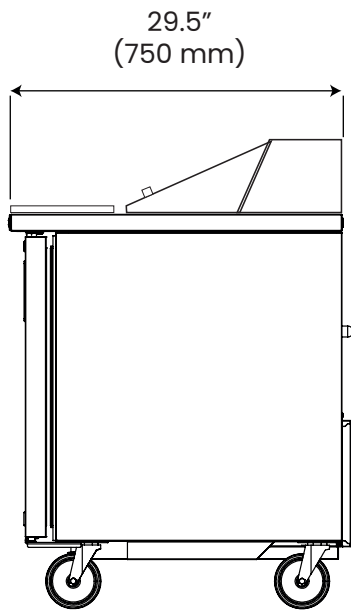

Electric Data

Voltage	115/60/1
Plug Type	NEMA 5-15P
Compressor HP	1/2
Refrigerant	R290

Dimensional Data

Capacity - cu. ft.	15 ft ³ (424.7 liters)
Net Weight - Lbs.	319 Lbs. (145 Kg)



Drago America
www.dragoamerica.com
(346) 374-8343
9777 W. Gulf Bank Road Suite 200, Houston, Texas 77040