



Drago America
www.dragoamerica.com

Project Name: _____

Location: _____

Item #: _____ Qty: _____

Model #: _____

SIA #

AIA #

Model:
DRUC27F

Freezers – Undercounter Freezer
1 solid door 6 ft³



Features & Benefits

Strong & Durable Structure

- Stainless steel interior and exterior, aluminum back.

Temperature

- Temperature range -7°F~0°F (-22°C~-18°C).

User Friendly Features

- Self-closing doors with 90 degree stay-open feature.
- Adjustable heavy duty PVC coated shelves.
- Easy access to condenser coil for cleaning and service.
- Easy adjust temperature set point and defrost frequency.

Pre-installed heavy-duty casters with brakes.
Refrigerant R290.



Certifications



Intertek



Intertek

Doors	Shelves	HP	AMPS	Crated Weight	Dimensions (inches)		
					W	D	H
1	1	3/7	3.6	180.7 Lb (82 Kg)	27" (685 mm)	29.5" (750 mm)	35.2" (895 mm)

Packaging dimensions (mm): W 30" (755) x D 32" (820) x H 38.5" (980)

Approvals:

Available At:

Model:
DRUC27F

Freezers - Undercounter Freezer

1 solid door 6 ft³



Plan View

Front View

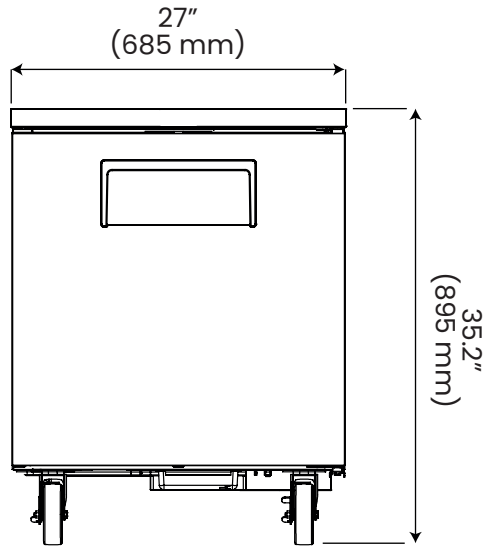

Side View

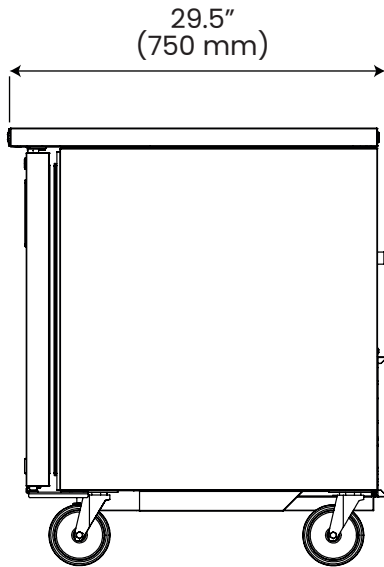

Spec

Electric Data

Voltage	115/60/1
Plug Type	NEMA 5-15P
Compressor HP	3/7
Refrigerant	R290

Dimensional Data

Capacity - cu. ft.	6 ft ³ (169.9 liters)
Net Weight - Lbs.	158.4 Lbs. (72 Kg)

DRAGO

Drago America
www.dragoamerica.com
(346) 374-8343

9777 W. Gulf Bank Road Suite 200, Houston, Texas 77040