



Drago America  
www.dragoamerica.com

Project Name: \_\_\_\_\_

Location: \_\_\_\_\_

Item #: \_\_\_\_\_ Qty: \_\_\_\_\_

Model #: \_\_\_\_\_

SIA #

AIA #

Model:  
DRSP48-12

## Prep Tables – Sandwich Prep Table

2 solid doors 10 ft<sup>3</sup>



### Features & Benefits

#### Strong & Durable Structure

- Stainless steel interior and exterior, aluminum back.

#### Temperature

- Temperature range 33°F~40°F (0°C~4°C).

#### User Friendly Features

- Self-closing doors with 90 degree stay-open feature.
- Adjustable heavy duty PVC coated shelves.
- Easy access to condenser coil for cleaning and service.
- Easy adjust temperature set point and defrost frequency.

**Pre-installed heavy-duty casters with brakes.**

**Refrigerant R290.**



### Certifications



Intertek



Intertek

Doors	Shelves	Pans	Pans Size	HP	AMPS	Crated Weight	Dimensions (inches)		
							W	D	H
2	2	12	1/6	1/2	4.9	280 lb (127 Kg)	46.8" (1188 mm)	29.5" (750 mm)	42.4" (1076.9 mm)

Packaging dimensions: W 51.9" (1320 mm) x D 34.6" (880 mm) x H 45.5" (1157 mm).

Approvals:

Available At:

Model:  
DRSP48-12

# Prep Tables – Sandwich Prep Table

2 solid doors 10 ft<sup>3</sup>



Front View

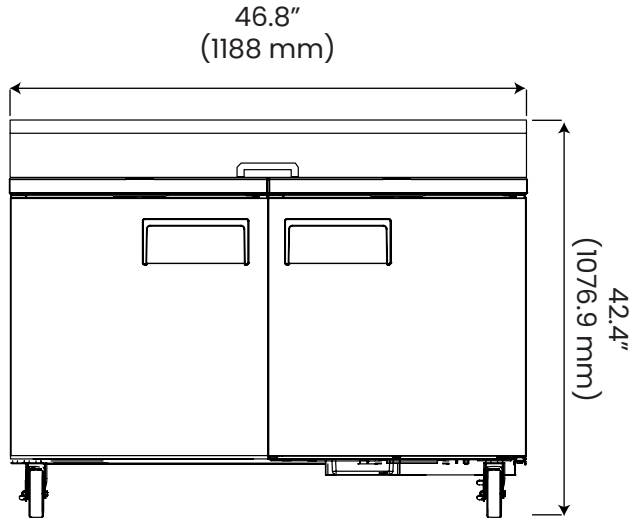

Side View

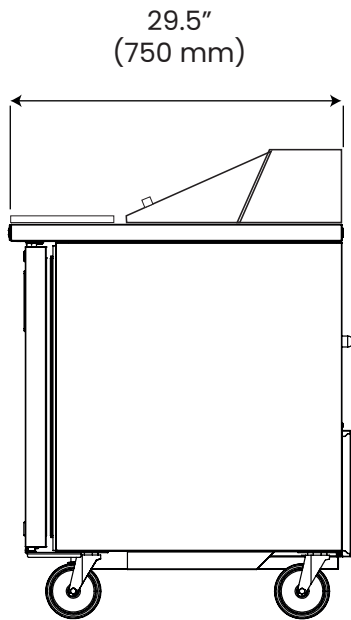

## Electric Data

Voltage	115/60/1
Plug Type	NEMA 5-15P
Compressor HP	1/2
Refrigerant	R290

## Dimensional Data

Capacity - cu. ft.	10 ft <sup>3</sup> (283.1 liters)
Net Weight - Lbs.	253 Lbs. (115 Kg)



Drago America  
www.dragoamerica.com  
(346) 374-8343  
9777 W. Gulf Bank Road Suite 200, Houston, Texas 77040