



Drago America
www.dragoamerica.com

Project Name: _____

SIA #

Location: _____

Item #: _____ Qty: _____

AIA #

Model #: _____

Model:
DR72R

Refrigerators – Solid Door Reach In

3 solid doors refrigerator 72 ft³



Features & Benefits

Strong & Durable Structure

- Stainless steel interior and exterior.
- Aluminum back exterior.

Temperature

- Temperature range 33°F~40°F (0°C~4°C).

User Friendly Features

- Self-closing solid doors with 90 degrees stay open feature. Locks and keys included.
- Recessed handles for ease of opening and cleaning.
- Adjustable heavy duty PVC coated shelves.
- Easy access to condenser coil for cleaning and service.
- Easy adjust temperature set point and defrost frequency.

Pre-installed heavy-duty casters with brakes.

Refrigerant R290.

Certifications



Intertek



Intertek

Doors	Shelves	HP	AMPS	Crated Weight	Dimensions (inches)		
					W	D	H
3	9	4/5	7.2	695 Lb (315 Kg)	81" (2057.4 mm)	32.2" (818 mm)	82.5" (2095 mm)

Packaging dimensions: W 83.6" (2125 mm) x D 34.6" (880 mm) x H 84.4" (2145 mm).

Approvals:

Available At:

Model:
DR72R

Refrigerators - Solid Door Reach In

3 solid doors refrigerator 72 ft³



Plan View

Front View

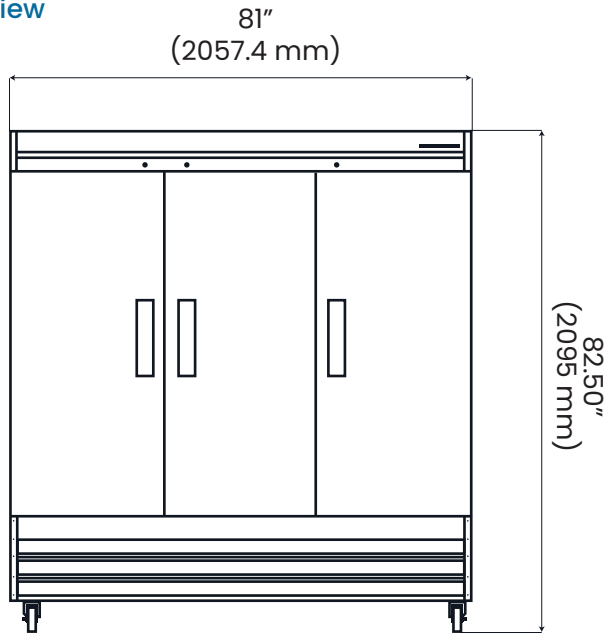

Spec

Electric Data	
Voltage	115/60/1
Plug Type	NEMA 5-15P
Compressor HP	4/5
Refrigerant	R290

Dimensional Data	
Capacity - cu. ft.	72 ft ³ (2038.8 liters)
Net Weight - Lbs.	613.8 Lbs (279 Kg)

Side View

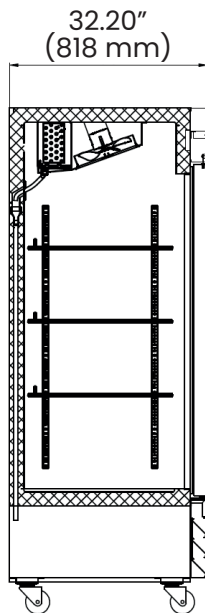

Drago America
www.dragoamerica.com
(346) 374-8343
9777 W. Gulf Bank Road Suite 200, Houston, Texas 77040