



Drago America
www.dragoamerica.com

Project Name: _____

Location: _____

Item #: _____ Qty: _____

Model #: _____

SIA #

AIA #

Model:
DRDC48

Deli Case
18 ft³



**DRAGO
REFRIGERATION**



Features & Benefits

Strong & Durable Structure

- Aluminum liner with stainless steel floor interior.
- Pre-painted black steel sheet exterior.

Temperature

- Temperature range 32°F~43°F (0°C~6°C).

User Friendly Features

- Attractive curved glass and sliding glass door.
- Rounded corner design inside the cabinet.
- Easy access for cleaning the interior of the storage room.
- LED interior lighting.
- Adjustable heavy duty PVC coated shelves.
- Easy access to condenser coil for cleaning and service.
- Easy adjust temperature set point and defrost frequency.

Refrigerant R290.



Certifications



Intertek



Intertek

Doors	Shelves	HP	AMPS	Crated Weight	Dimensions (inches)		
					W	D	H
2	6	1/3	4.5	388 Lb (176 Kg)	47.3" (1201.4 mm)	32.5" (825 mm)	42.9" (1089.6 mm)

Packaging dimensions (mm): W 51" (1300) x D 37" (940) x H 49" (1240)

Approvals:

Available At:

Model:
DRDC48

Deli Case
18 ft³



Plan View

Front View

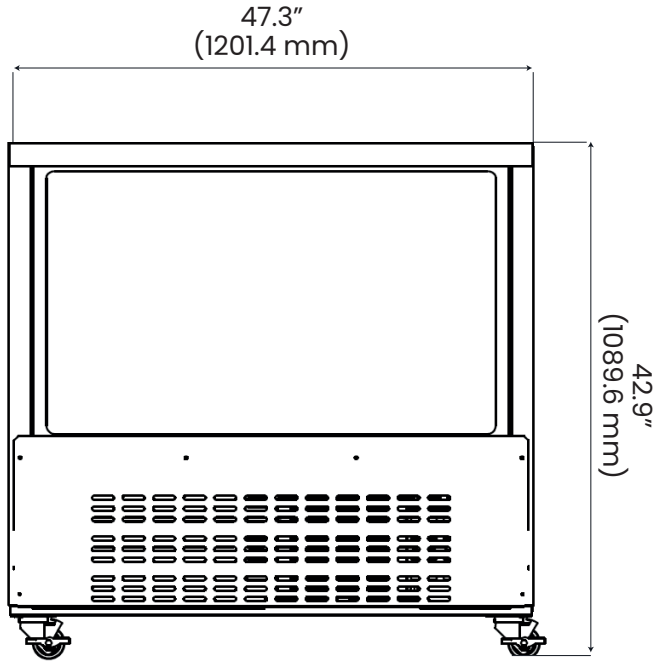

Side View

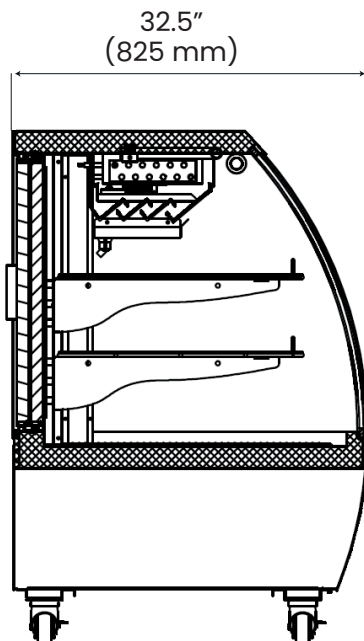

Spec

Electric Data

Voltage	115/60/1
Plug Type	NEMA 5-15P
Compressor HP	1/3
Refrigerant	R290

Dimensional Data

Capacity - cu. ft.	18 ft ³ (509.7 liters)
Net Weight - Lbs.	320 Lbs (145 Kg)

DRAGO

Drago America
www.dragoamerica.com
(346) 374-8343
9777 W. Gulf Bank Road Suite 200, Houston, Texas 77040