



Drago America
www.dragoamerica.com

Project Name: _____

Location: _____

Item #: _____ Qty: _____

Model #: _____

SIA #

AIA #

Model:
DRBB72SH

Coolers – Solid Door Hinged Back Bar Cooler

3 solid door 20 ft³



DRAGO
REGRIGATION



Features & Benefits

Strong & Durable Structure

- Stainless steel top, interior walls, floor and ceiling.
- Corrosion resistant vinyl on steel in black finish.

Temperature

- Temperature range 33°F~40°F (0°C~4°C).

User Friendly Features

- Self-closing doors with locks.
- Option of stainless steel exterior available.
- LED interior lighting.
- Adjustable heavy duty PVC coated shelves.
- Easy access to condenser coil for cleaning and service.
- Easy adjust temperature set point and defrost frequency.

Pre-installed heavy-duty casters with brakes.

Refrigerant R290.



Certifications



Intertek



Intertek

Doors	Shelves	HP	AMPS	Crated Weight	Dimensions (inches)		
					W	D	H
3	4	3/7	4.1	337.3 lb (153 Kg)	72.8" (1849.1 mm)	34.4" (873.7 mm)	35.6" (905 mm)

Packaging dimensions (mm): W 75" (1910) x D 27.5" (700) x H 42" (1060)

Approvals:

Available At:

Model:
DRBB72SH

Coolers – Solid Door Hinged Back Bar Cooler

3 solid door 20 ft³



Plan View

Front View

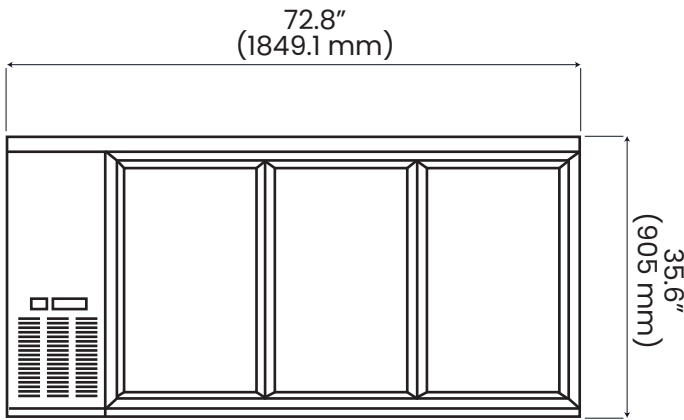

Side View

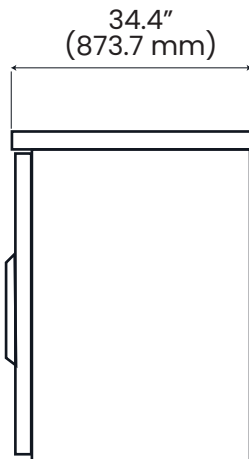

Spec

Electric Data

Voltage	115/60/1
Plug Type	NEMA 5-15P
Compressor HP	3/7
Refrigerant	R290

Dimensional Data

Capacity - cu. ft.	20 ft ³ (566.3 liters)
Net Weight - Lbs.	330 Lbs. (150 Kg)

DRAGO

Drago America
www.dragoamerica.com
(346) 374-8343
9777 W. Gulf Bank Road Suite 200, Houston, Texas 77040