



Drago America
www.dragoamerica.com

Project Name: _____

Location: _____

Item #: _____ Qty: _____

Model #: _____

SIA #

AIA #

Model:
DRUC60R

Refrigerators – Undercounter Refrigerator

2 solid doors 15 ft³



DRAGO
REFRIGERATION



Features & Benefits

Strong & Durable Structure

- Stainless steel interior and exterior, aluminum back.

Temperature

- Temperature range 33°F~40°F (0°C~4°C).

User Friendly Features

- Self-closing doors with 90 degree stay-open feature.
- Adjustable heavy duty PVC coated shelves.
- Easy access to condenser coil for cleaning and service.
- Easy adjust temperature set point and defrost frequency.

**Pre-installed heavy-duty casters with brakes.
Refrigerant R290.**



Certifications



Intertek



Intertek

Doors	Shelves	HP	AMPS	Crated Weight	Dimensions (inches)		
					W	D	H
2	2	1/3	2.6	313 Lb (142 Kg)	60.2" (1529 mm)	29.5" (750 mm)	35.2" (895 mm)

Packaging dimensions (mm): W 63" (1600) x D 32.3" (820) x H 38.6" (980)

Approvals:

Available At:

Model:
DRUC60R

Refrigerators - Undercounter Refrigerator

2 solid doors 15 ft³



Plan View

Front View

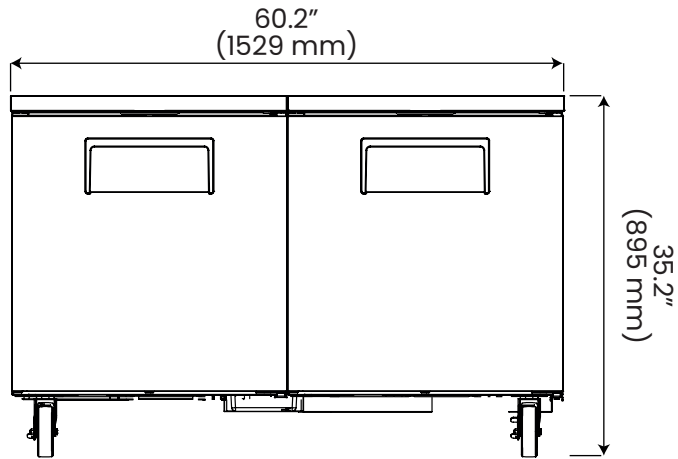

Side View

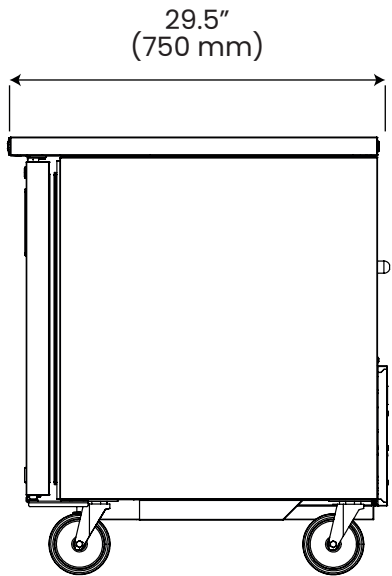

Spec

Electric Data

Voltage	115/60/1
Plug Type	NEMA 5-15P
Compressor HP	1/3
Refrigerant	R290

Dimensional Data

Capacity - cu. ft.	15 ft ³ (424.7 liters)
Net Weight - Lbs.	253 Lbs. (115 Kg)

DRAGO

Drago America
www.dragoamerica.com
(346) 374-8343

9777 W. Gulf Bank Road Suite 200, Houston, Texas 77040