



Drago America
www.dragoamerica.com

Project Name: _____

SIA #

Location: _____

Item #: _____ Qty: _____

AIA #

Model #: _____

Model:
DRHP36

Hot Plate
36"



Features & Benefits

Strong & Durable Structure

- Front, sides, and plating area made of stainless steel.
- Welded and polished stainless steel joints in the plating area and valve panel.
- Stove-level working height when placed on a modular base. *Work bases sold separately.
- 3.2" (82 mm) plating area.
- Heavy-duty metal knobs with thermal protection.
- Removable tray for collecting residues.

Open Burners:

- Detachable and separate for easy cleaning.
- One stainless steel pilot per burner for instant ignition.

Grates:

- 12" x 12" (305 mm x 305 mm) grates.
- Heavy-duty cast iron structure.
- Easy and safe to remove for cleaning.



Certifications



Burners	Gas Output	Griddle Dimensions			Net Weight
		L	W	H	
6	176,000 Btu/hr	36" (914 mm)	27.3" (694 mm)	12.28" (312 mm)	167.5 Lb (76 Kg)

Approvals:

Available At:

Model:
DRHP36

Hot Plate
36"



Plan View

Front View

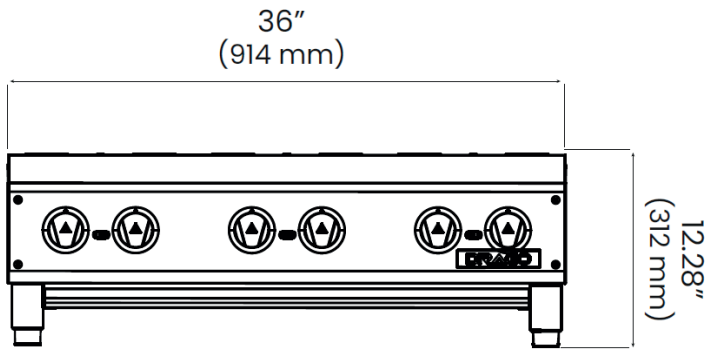

Side View

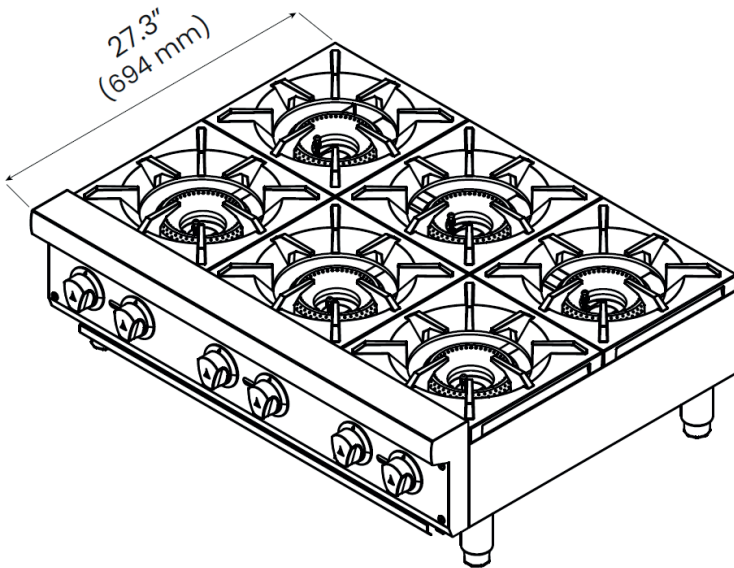

Spec

Gas Specifications:

Gas Type:	Propane / Natural
Manifold pressure:	11" W.C. / 5" W.C.
Gas connexion:	3/4"

Packaging data:

Dimensions:	L 39.9" (1014 mm) W 31.2" (795 mm) H 16.2" (412 mm)
Crated weight:	180.7 Lb (82 Kg)

DRAGO

Drago America
www.dragoamerica.com

(346) 374-8343

9777 W. Gulf Bank Road Suite 200, Houston, Texas 77040