



Drago America  
www.dragoamerica.com

Project Name: \_\_\_\_\_

Location: \_\_\_\_\_

Item #: \_\_\_\_\_ Qty: \_\_\_\_\_

Model #: \_\_\_\_\_

SIA #

AIA #

Model:  
DRCD72-2

**Cake Display Case**  
21 ft<sup>3</sup>



**Features & Benefits**

**Strong & Durable Structure**

- Stainless steel floor and walls, exterior.

**Temperature**

- Temperature range 32°F~43°F (0°C~6°C).

**User Friendly Features**

- Sliding doors.
- Tempered glass to avoid injury by broken glass.
- Preinstalled hidden caster design.
- 12V LED lighting system, safe for users to operate.
- Adjustable glass shelves, provide extra large viewing area to maximize product presentation.
- Easy access to condenser coil for cleaning and service.
- Easy adjust temperature set point and defrost frequency.
- NSF-7 compliant for open food product.

**Refrigerant R290.**



**Certifications**



**Intertek**



**Intertek**

| Doors | Shelves | HP  | AMPS  | Crated Weight      | Dimensions (inches)  |                     |                      |
|-------|---------|-----|-------|--------------------|----------------------|---------------------|----------------------|
|       |         |     |       |                    | W                    | D                   | H                    |
| 2     | 4       | 1/2 | 11.04 | 551 Lb<br>(250 Kg) | 70.9"<br>(1800.8 mm) | 28.8"<br>(731.5 mm) | 47.3"<br>(1201.4 mm) |

Packaging dimensions (mm): W 75" (1905) x D 33" (845) x H 52.5" (1332)

Approvals:

Available At:

Model:  
DRCD72-2

# Cake Display Case

21 ft<sup>3</sup>



Plan View

Front View

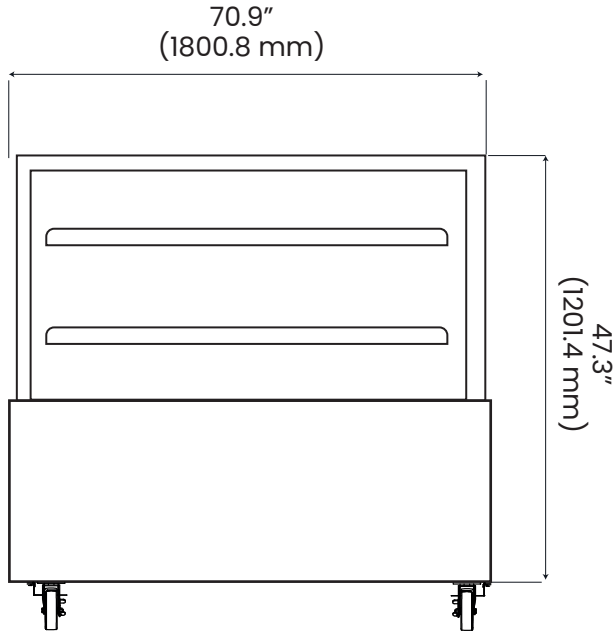

Side View

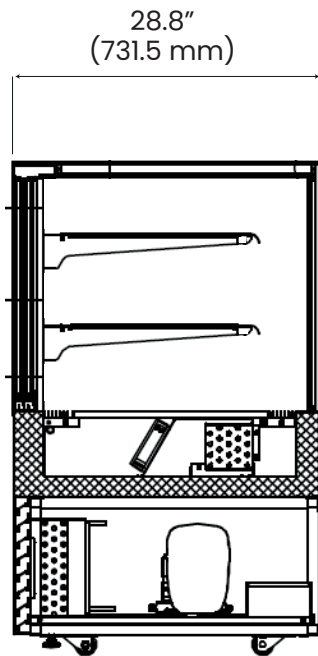

Spec

## Electric Data

|               |            |
|---------------|------------|
| Voltage       | 115/60/1   |
| Plug Type     | NEMA 5-15P |
| Compressor HP | 1/2        |
| Refrigerant   | R290       |

## Dimensional Data

|                    |                                   |
|--------------------|-----------------------------------|
| Capacity - cu. ft. | 21 ft <sup>3</sup> (594.6 liters) |
| Net Weight - Lbs.  | 652.5 Lbs (296 Kg)                |

# DRAGO

Drago America  
www.dragoamerica.com  
(346) 374-8343  
9777 W. Gulf Bank Road Suite 200, Houston, Texas 77040